



# **Faculty of Automotive and Construction Machinery Engineering**

WARSAW UNIVERSITY OF TECHNOLOGY

## ***Theory of Machines and Automatic Control*** Winter 2019/2020

**Lecturer: Sebastian Korczak, PhD Eng.**

# Lecture 11

Transfer function analysis – example.  
Block diagram algebra.  
Control and controllers.

# Example

Calculate and sketch step response and Bode Plots for a system with transfer function  $H(s) = 3/s$ .

# Example

Calculate and sketch step response and Bode Plots for a system with transfer function  $H(s) = 3/s$ .

# Example

Calculate and sketch step response and Bode Plots for a system with transfer function  $H(s) = 3/s$ .

# Example

Calculate and sketch step response and Bode Plots for a system with transfer function  $H(s) = 3/s$ .

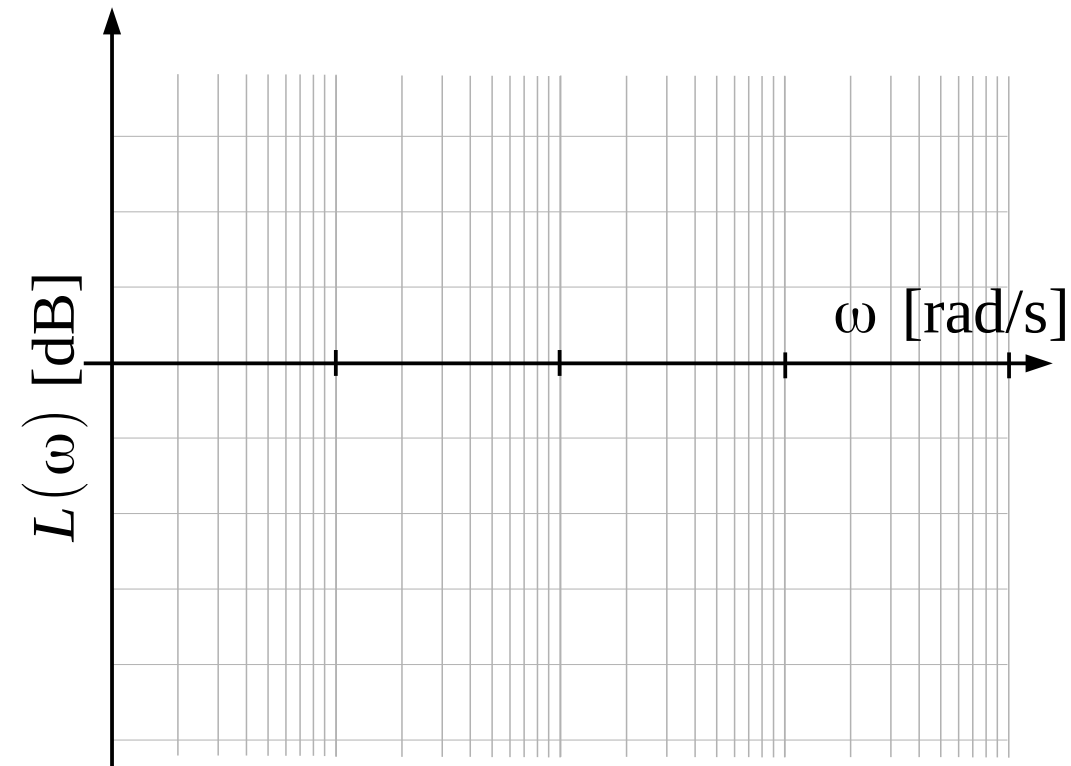

# Example

Calculate and sketch step response and Bode Plots for a system with transfer function  $H(s) = 3/s$ .

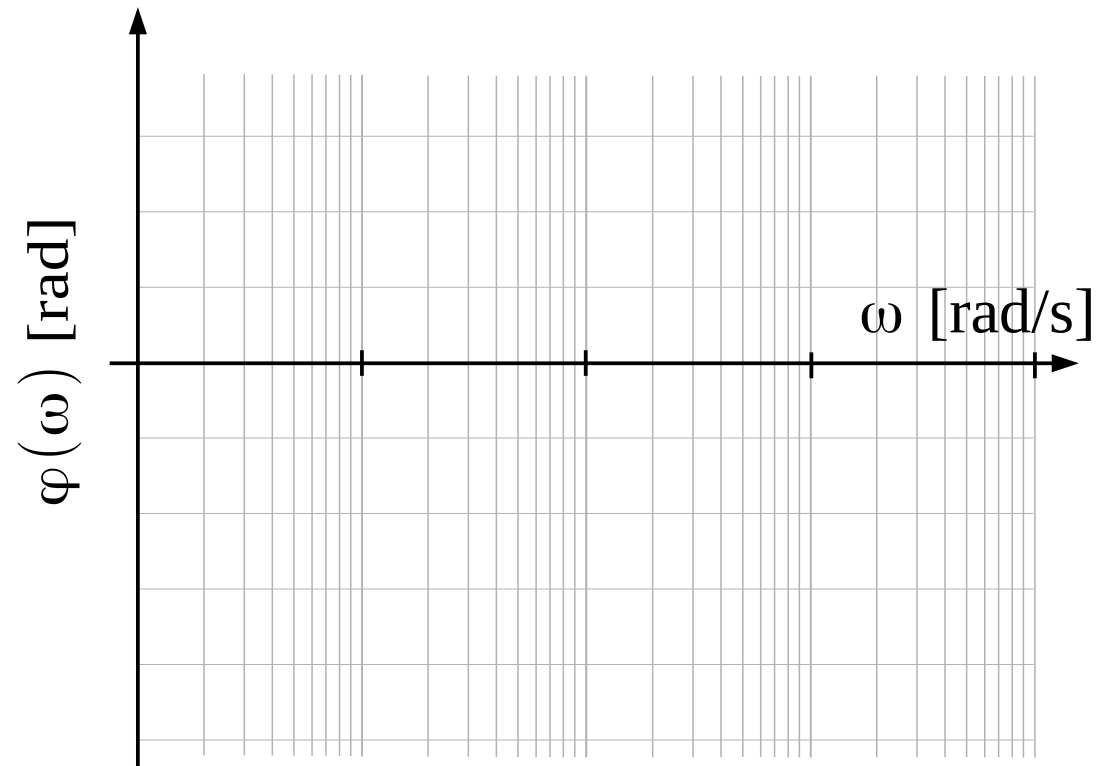

# BLOCK DIAGRAM ALGEBRA



# BLOCK DIAGRAM ALGEBRA

## Transfer function (SISO system)

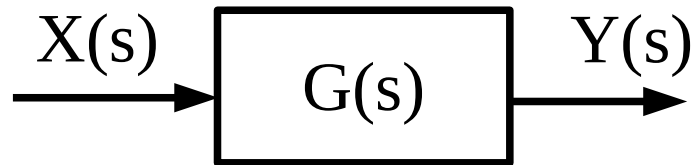

# BLOCK DIAGRAM ALGEBRA

## information node

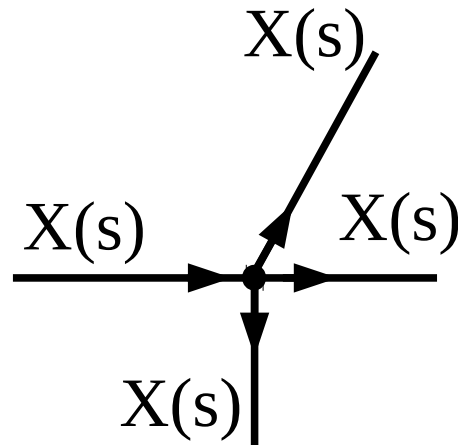

*one input,  
a few outputs,*

# BLOCK DIAGRAM ALGEBRA

## sum node

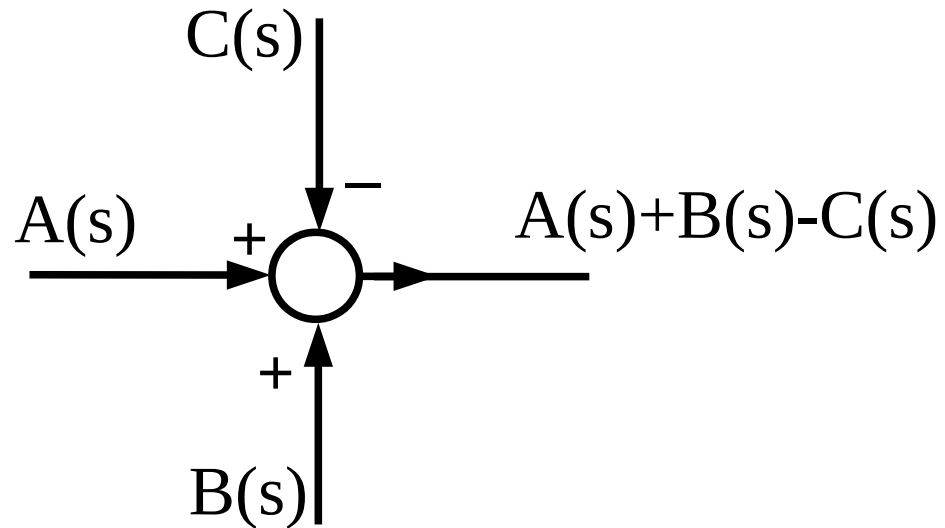

*a few inputs,  
one output,*

# BLOCK DIAGRAM ALGEBRA

## serial connection

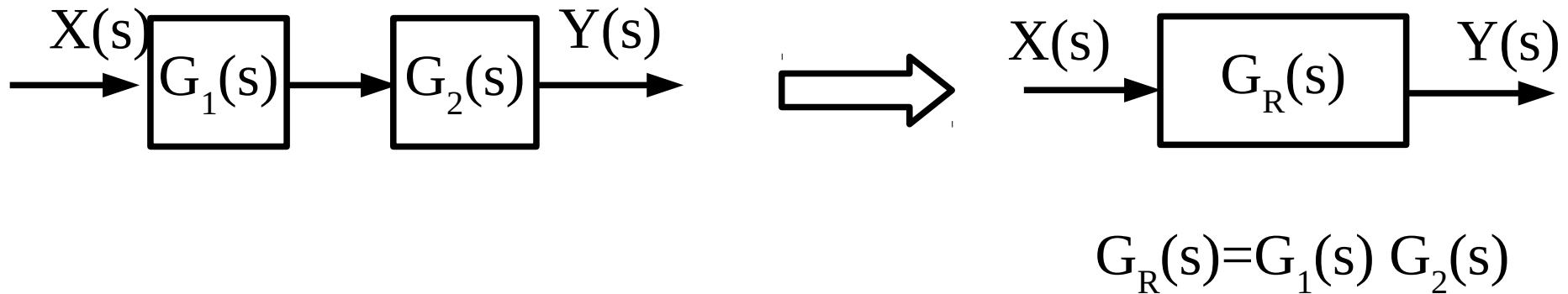

# BLOCK DIAGRAM ALGEBRA

## parallel connection

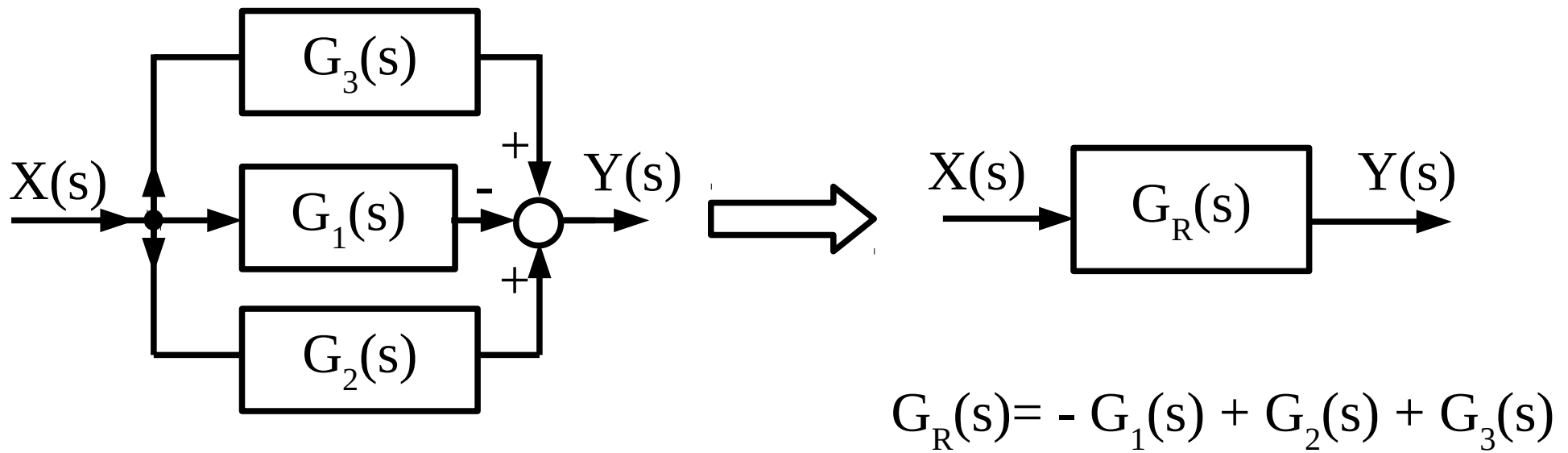

# BLOCK DIAGRAM ALGEBRA

## feedback

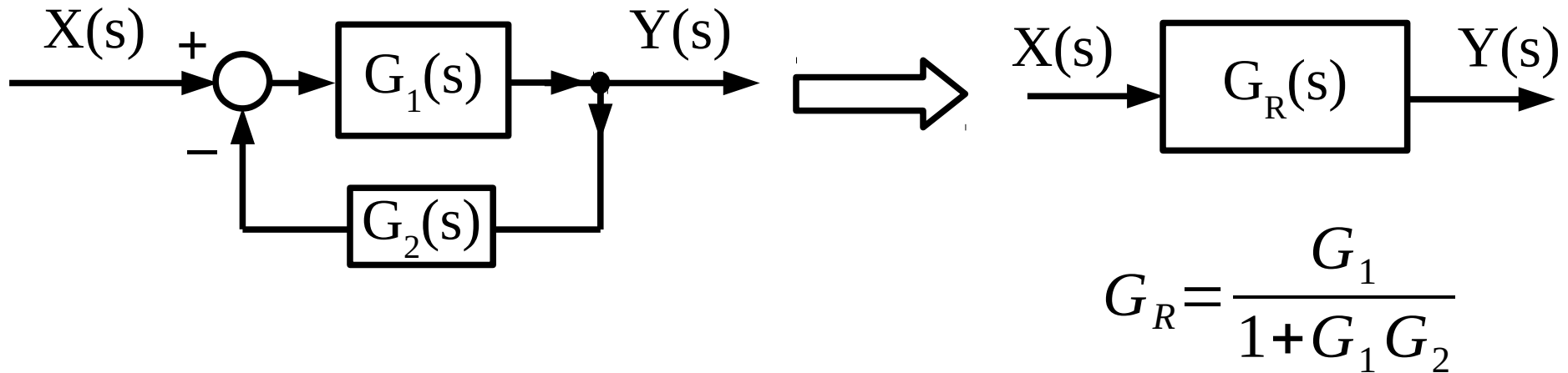

# BLOCK DIAGRAM ALGEBRA

## feedback

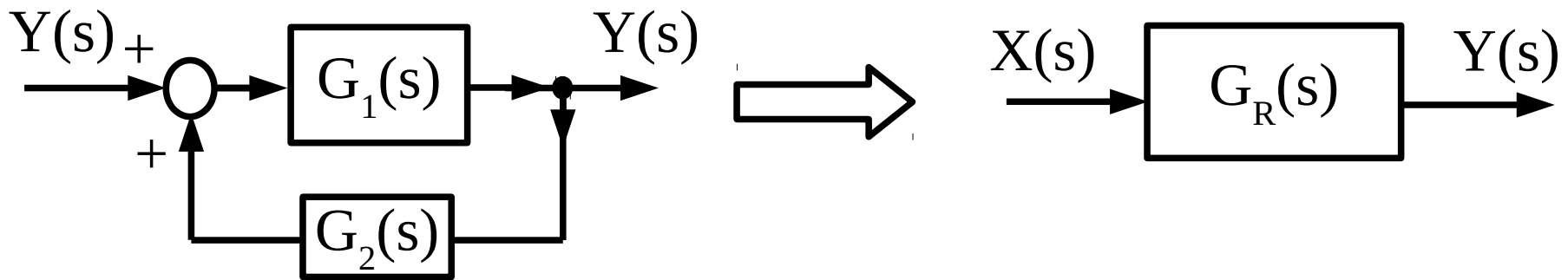

$$G_R = \frac{G_1}{1 - G_1 G_2}$$

# BLOCK DIAGRAM ALGEBRA

## feedback

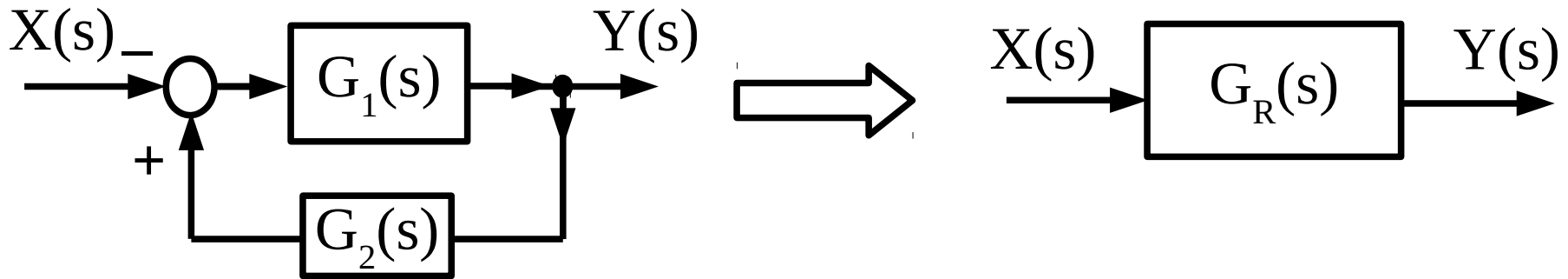

$$G_R = \frac{-G_1}{1 - G_1 G_2}$$



# EXAMPLE 1

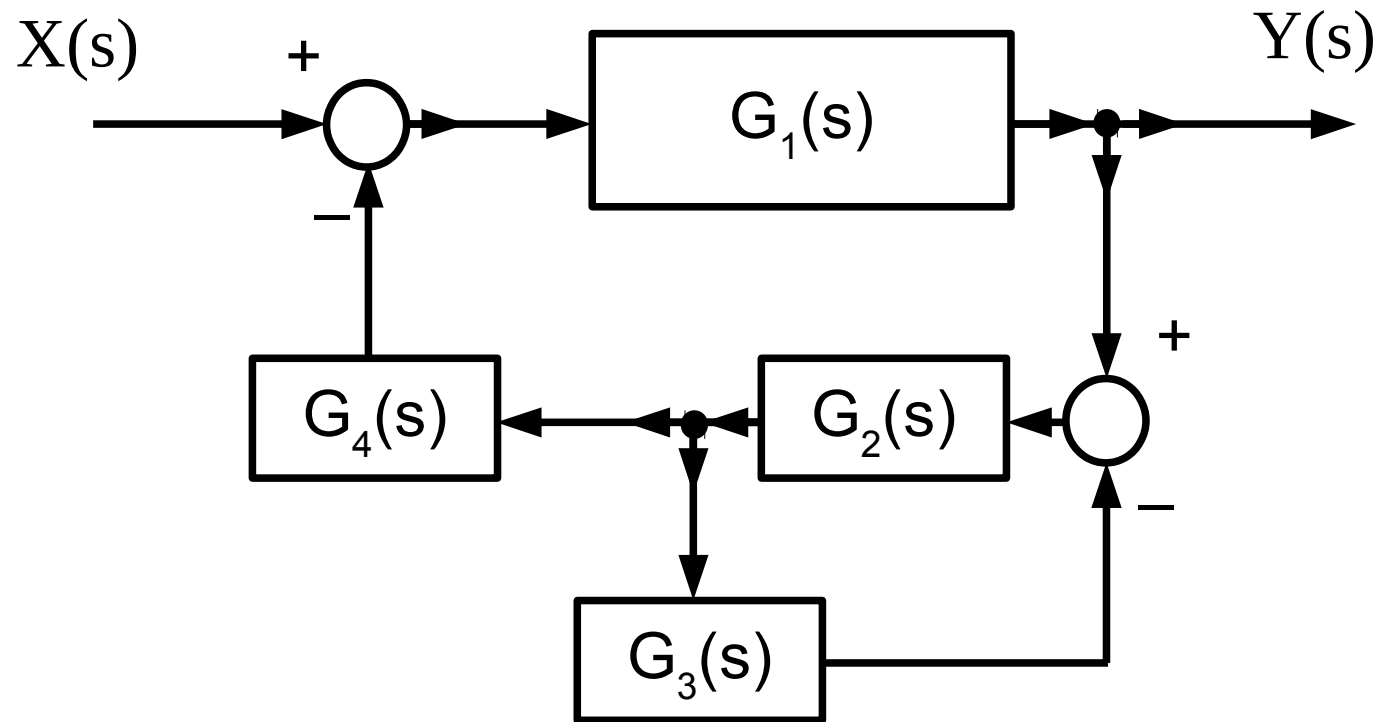

# EXAMPLE 1

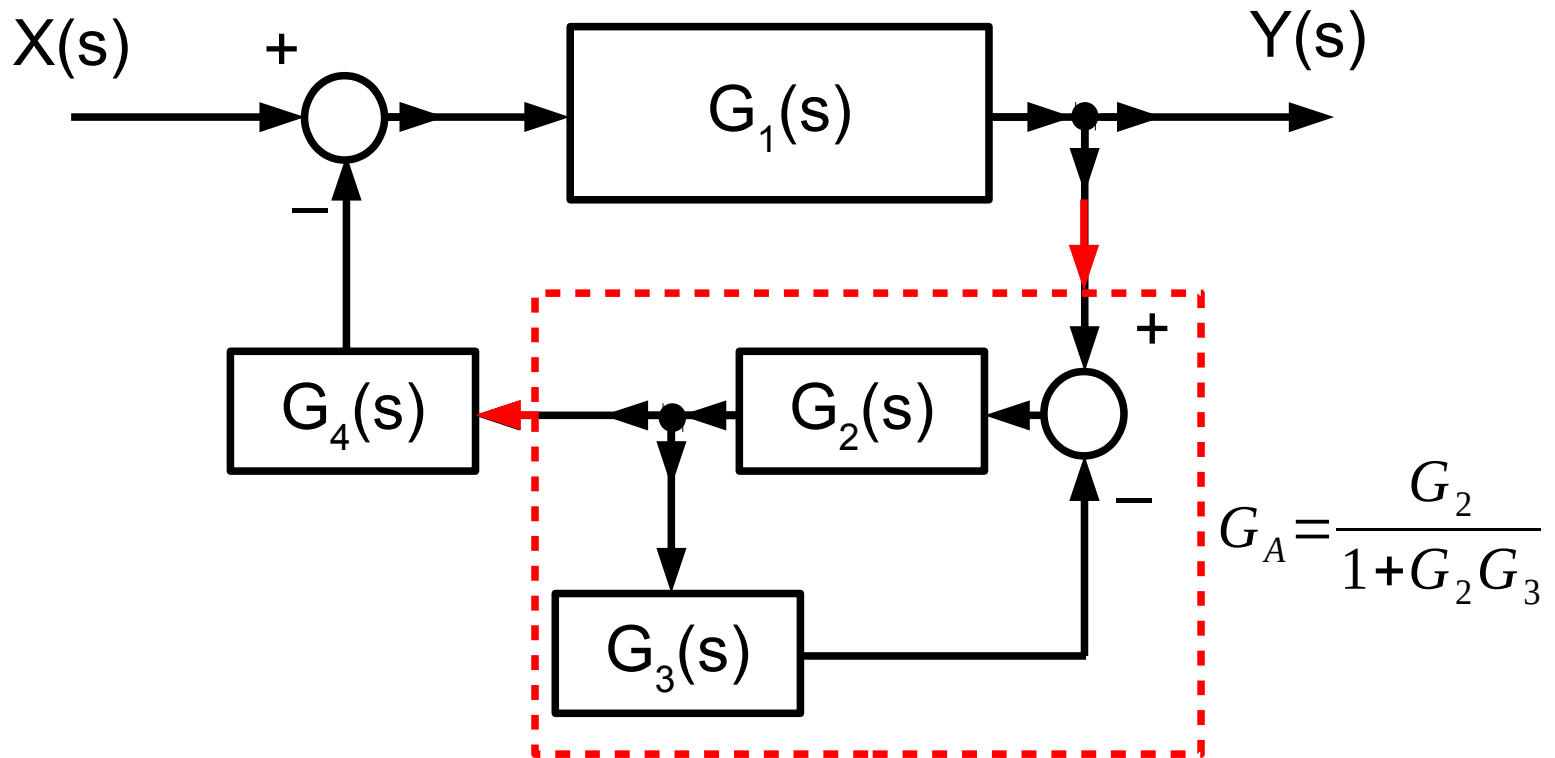

# EXAMPLE 1

$$G_A = \frac{G_2}{1 + G_2 G_3}$$

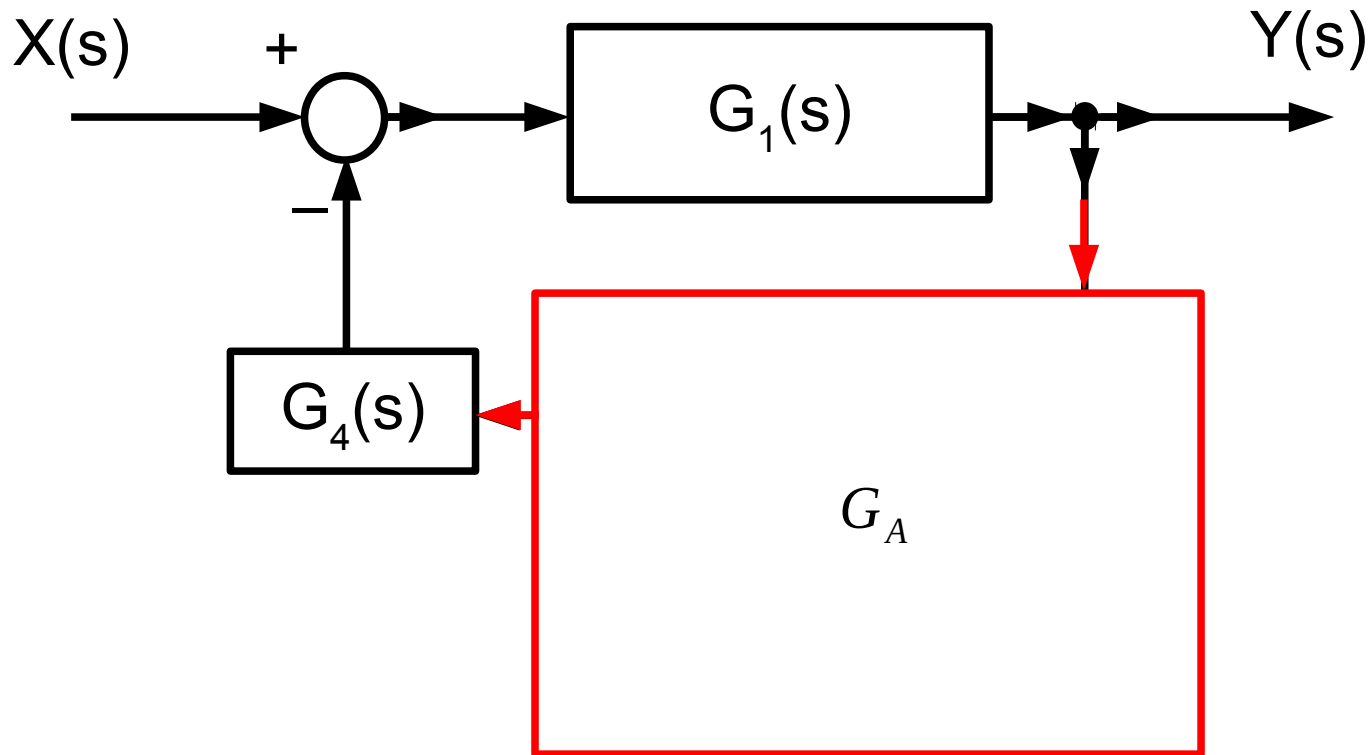

# EXAMPLE 1

$$G_A = \frac{G_2}{1 + G_2 G_3}$$

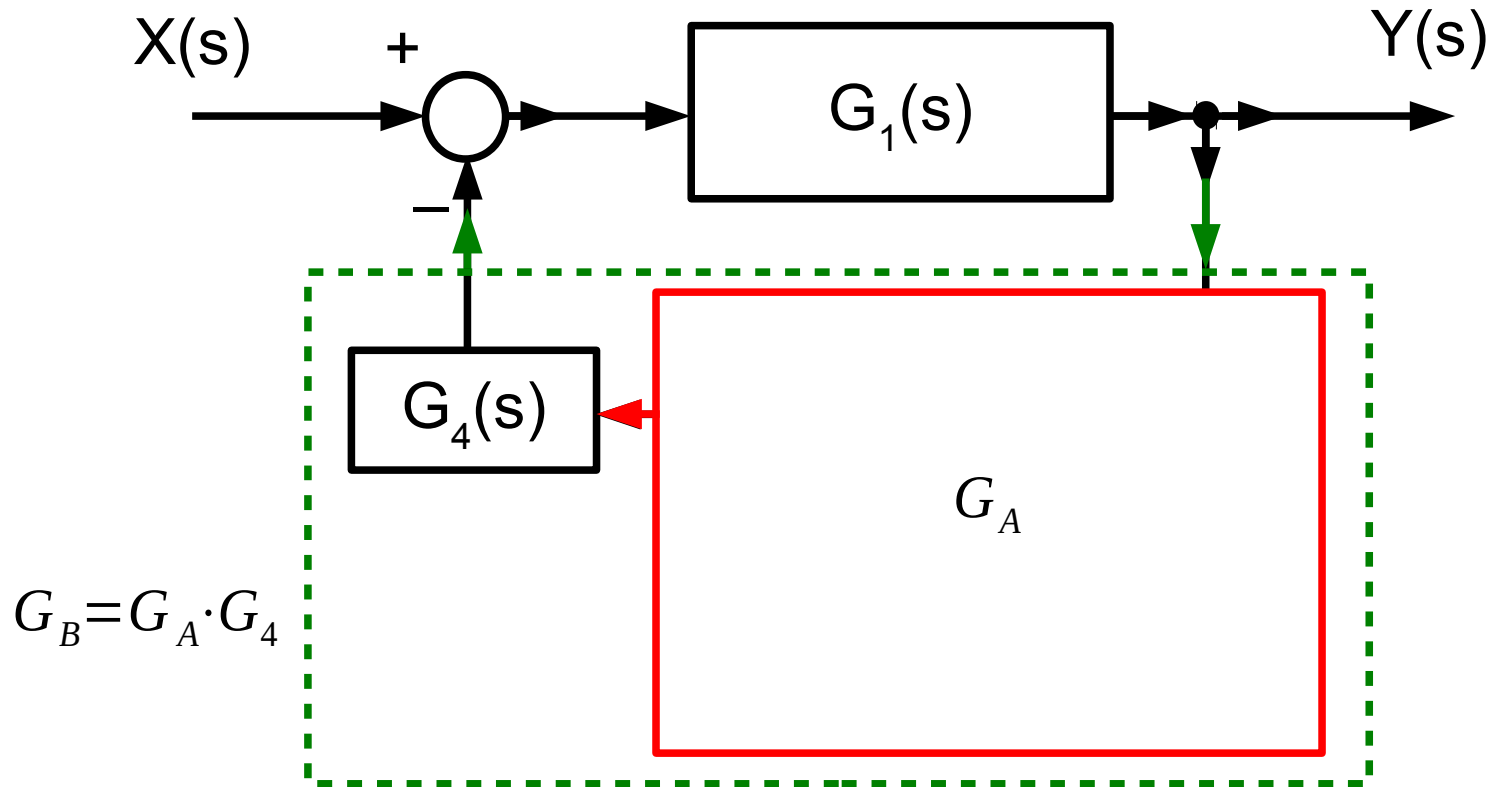

$$G_B = G_A \cdot G_4$$

# EXAMPLE 1

$$G_A = \frac{G_2}{1 + G_2 G_3}$$

$$G_B = G_A \cdot G_4$$

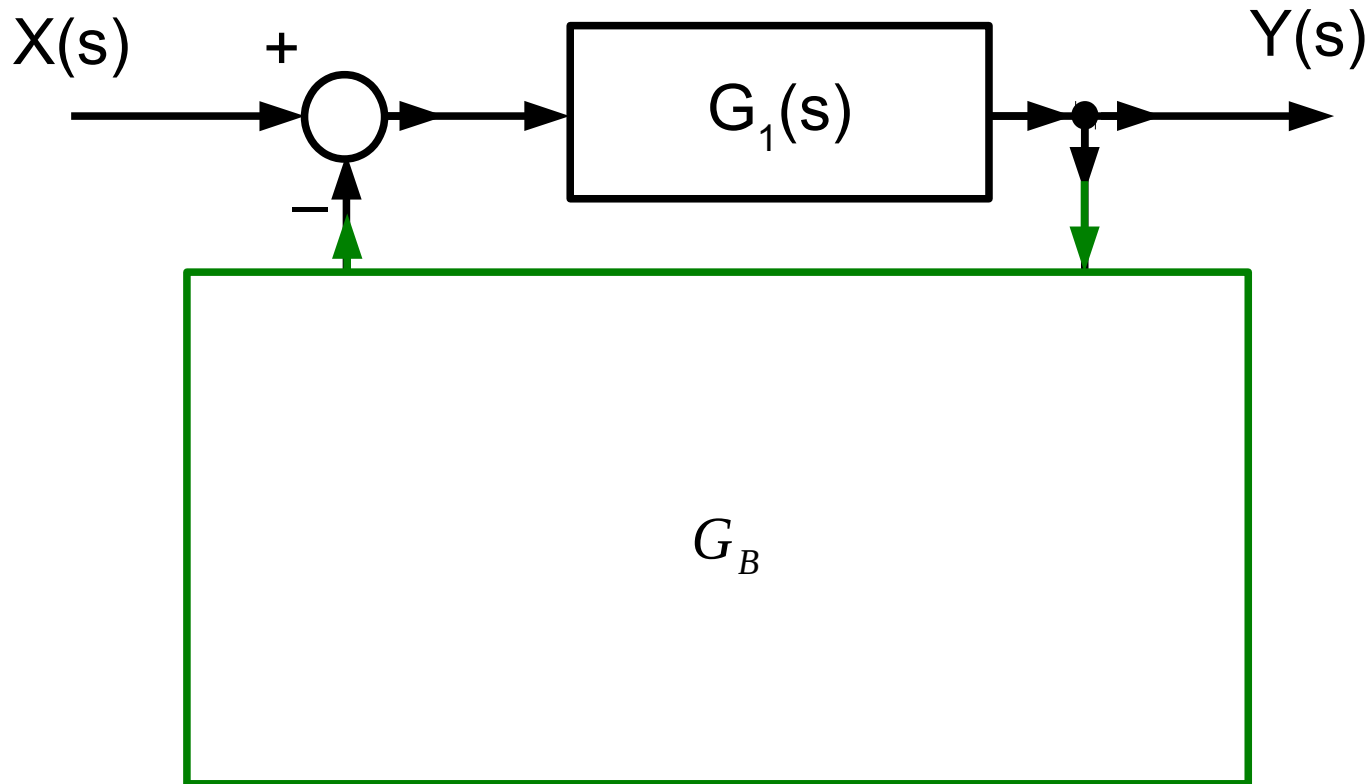

# EXAMPLE 1

$$G_A = \frac{G_2}{1 + G_2 G_3}$$

$$G_B = G_A \cdot G_4$$

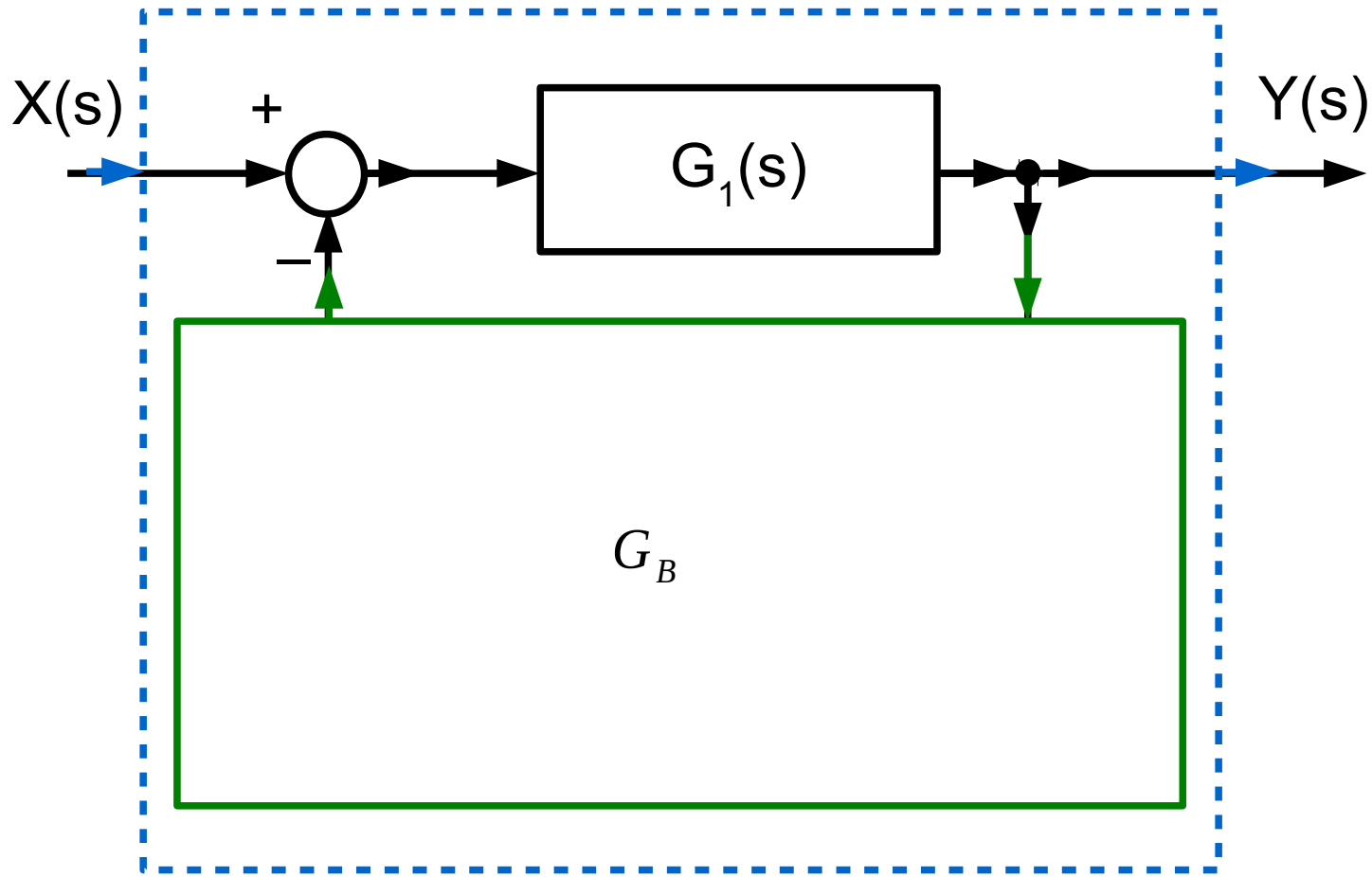

# EXAMPLE 1

$$G_A = \frac{G_2}{1 + G_2 G_3}$$

$$G_B = G_A \cdot G_4$$

$$G_R = \frac{Y(s)}{X(s)} = \frac{G_1}{1 + G_1 \cdot G_B}$$

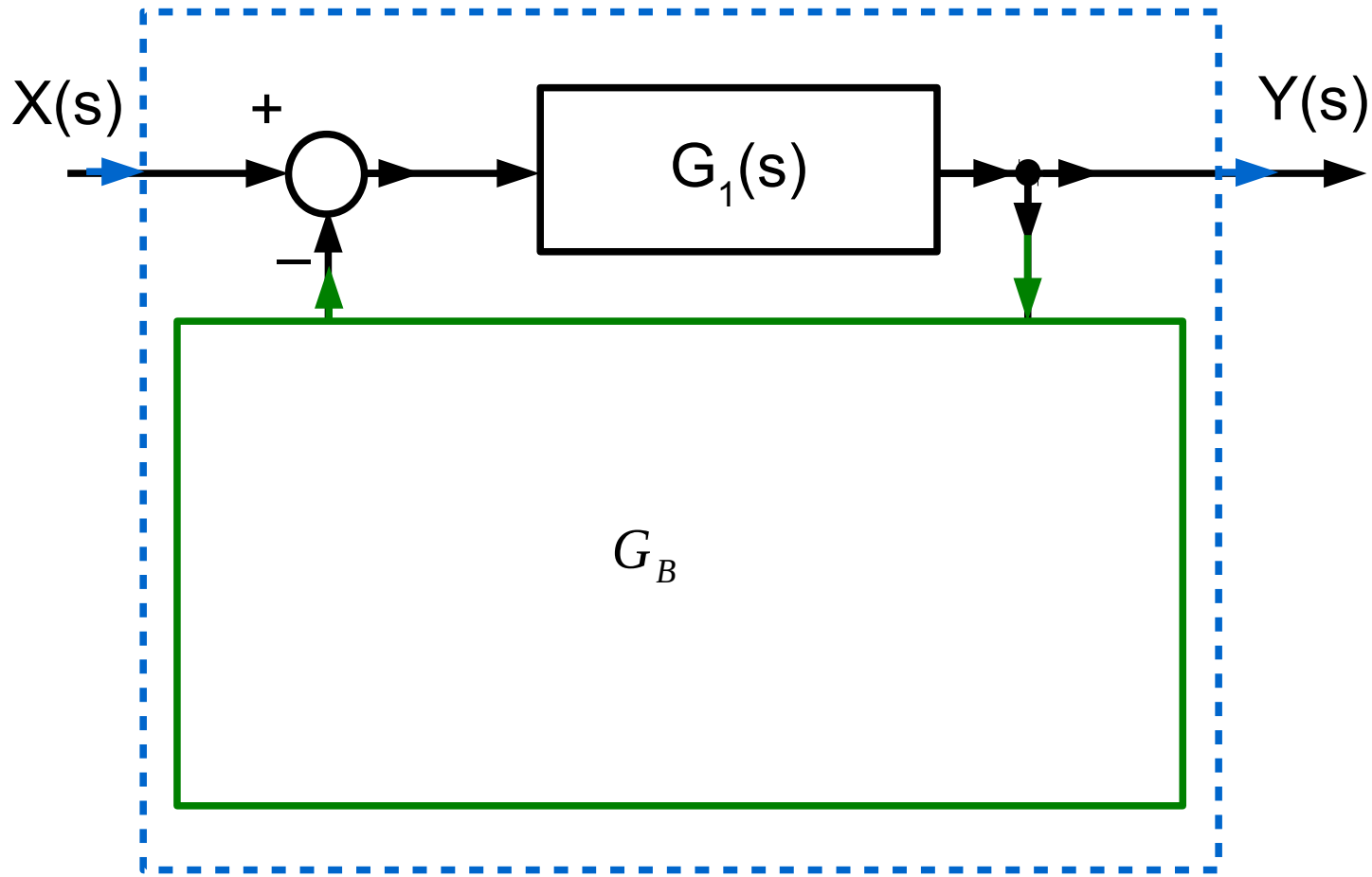

# EXAMPLE 1

$$G_A = \frac{G_2}{1 + G_2 G_3}$$

$$G_B = G_A \cdot G_4$$

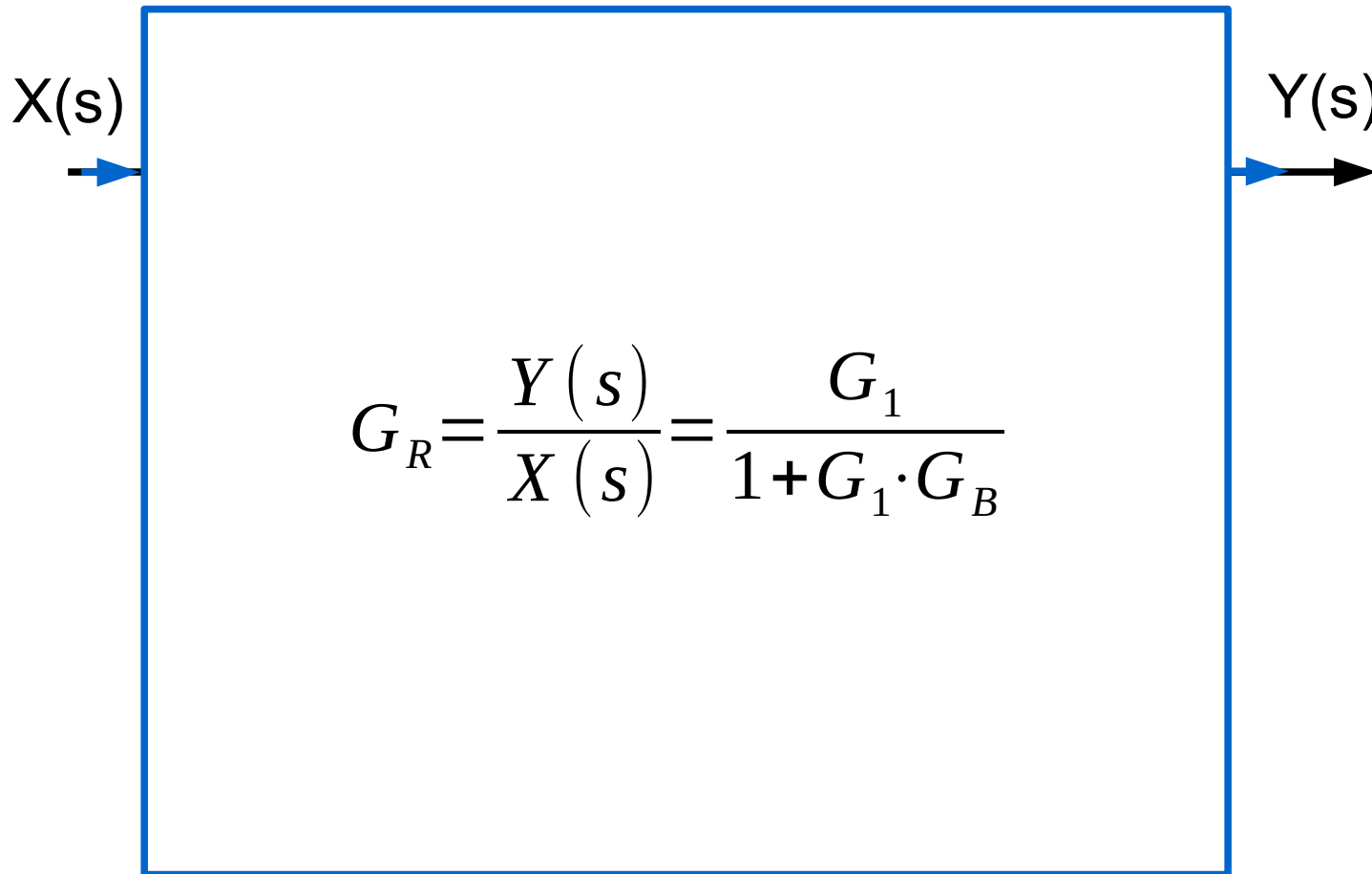



# EXAMPLE 2

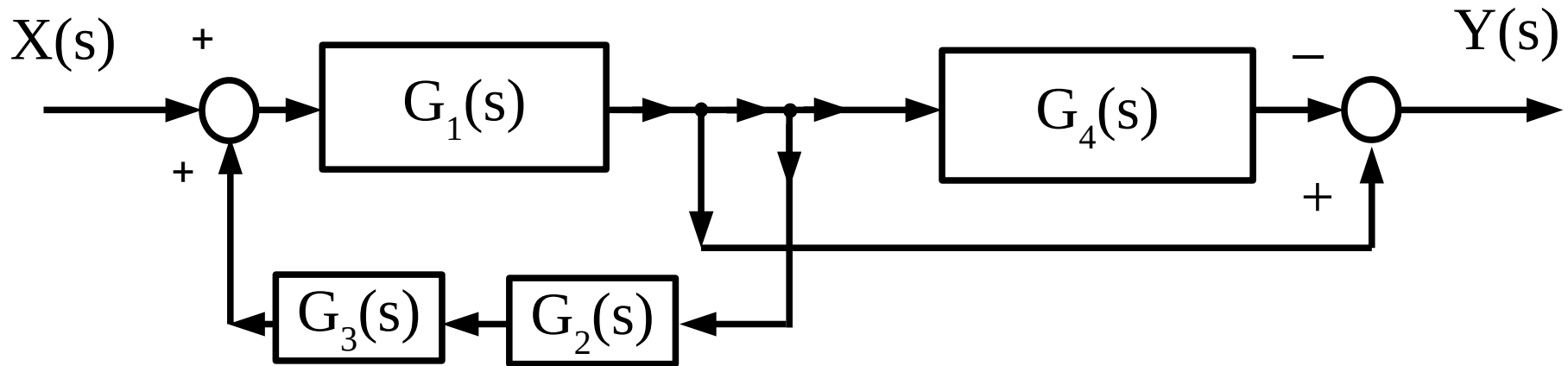

# EXAMPLE 2

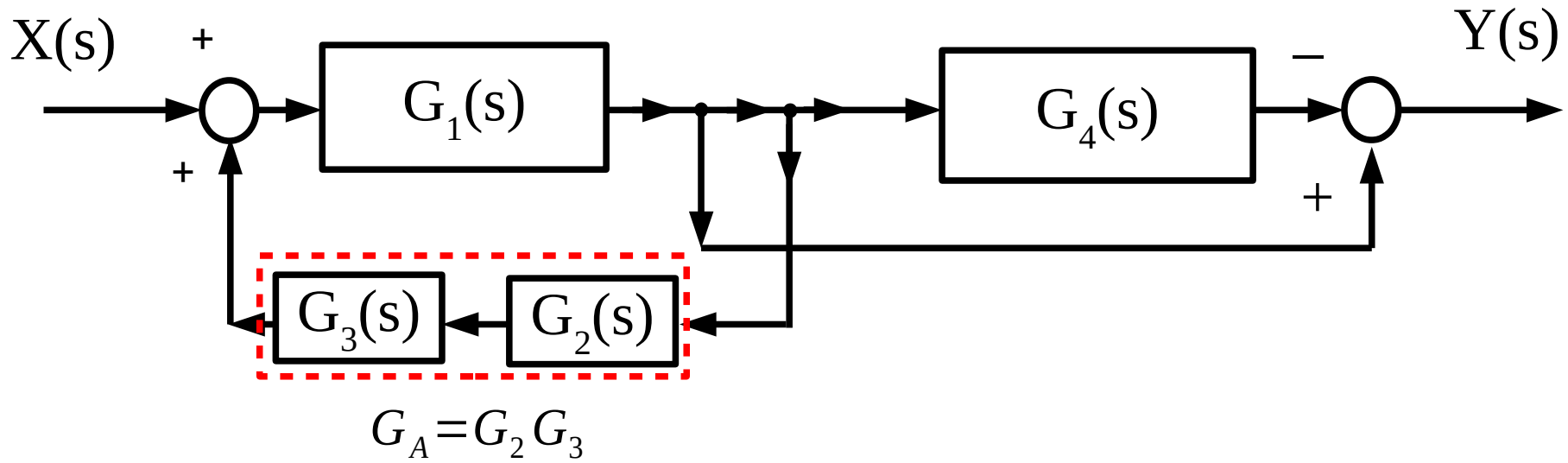

$$G_A = G_2 G_3$$

# EXAMPLE 2

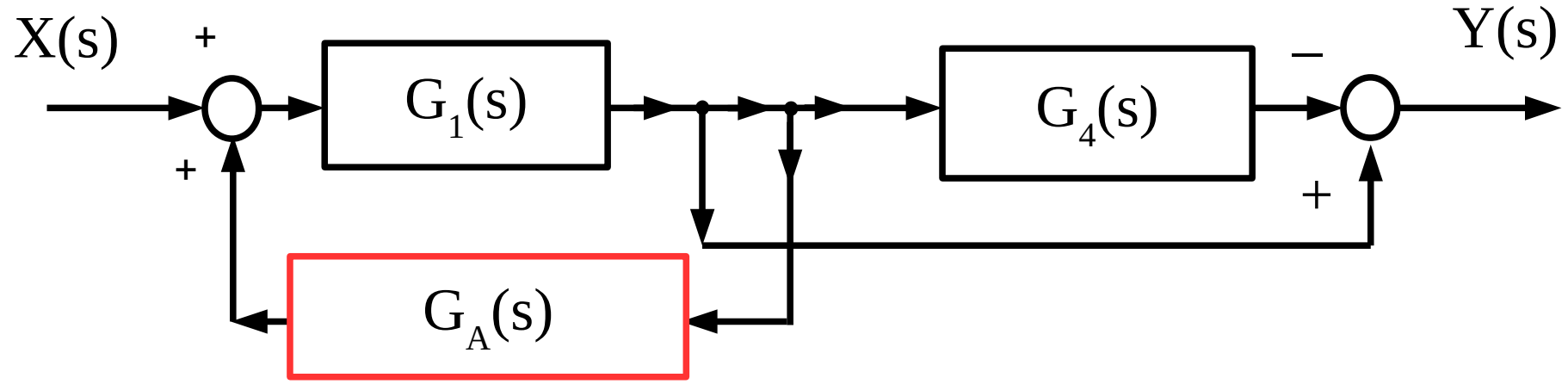

$$G_A = G_2 G_3$$

## EXAMPLE 2

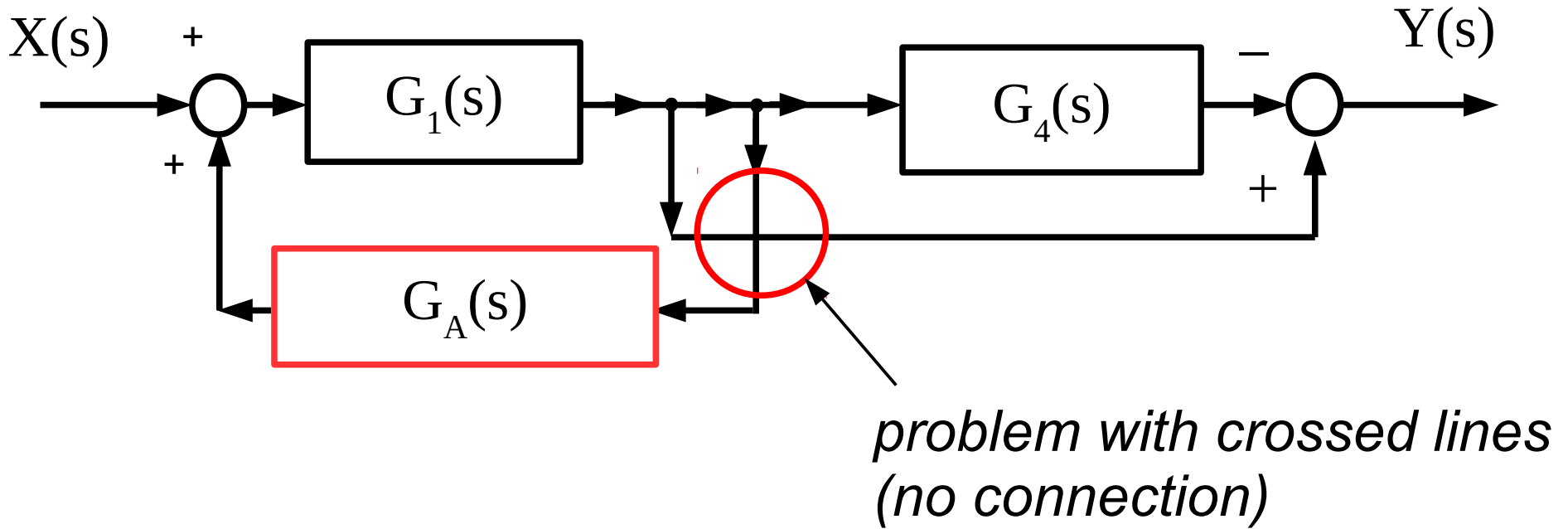

# BLOCK DIAGRAM ALGEBRA

## change of information points order

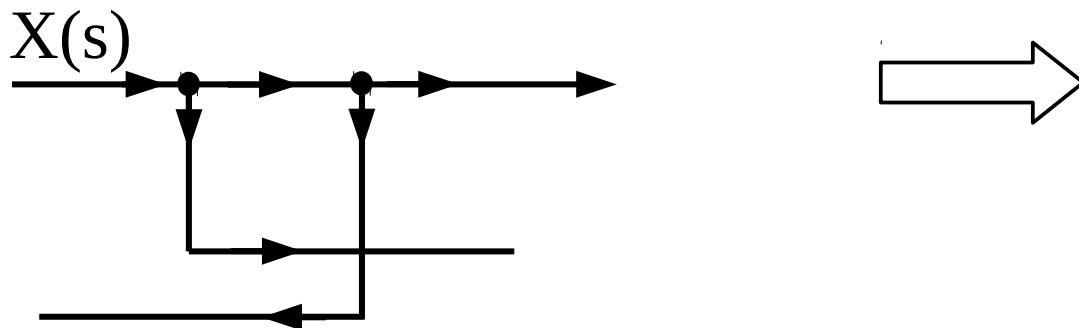

# BLOCK DIAGRAM ALGEBRA

## change of information points order

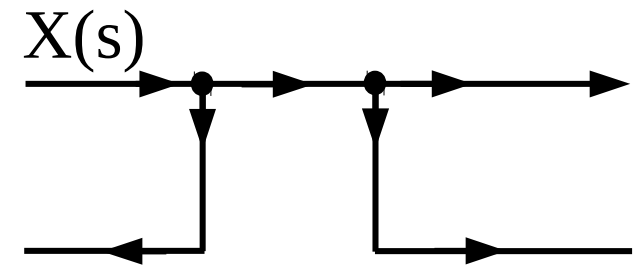
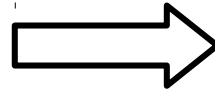
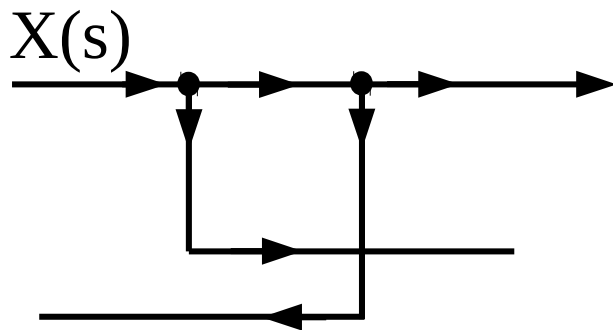

$$G_A = G_2 G_3$$

# EXAMPLE 2

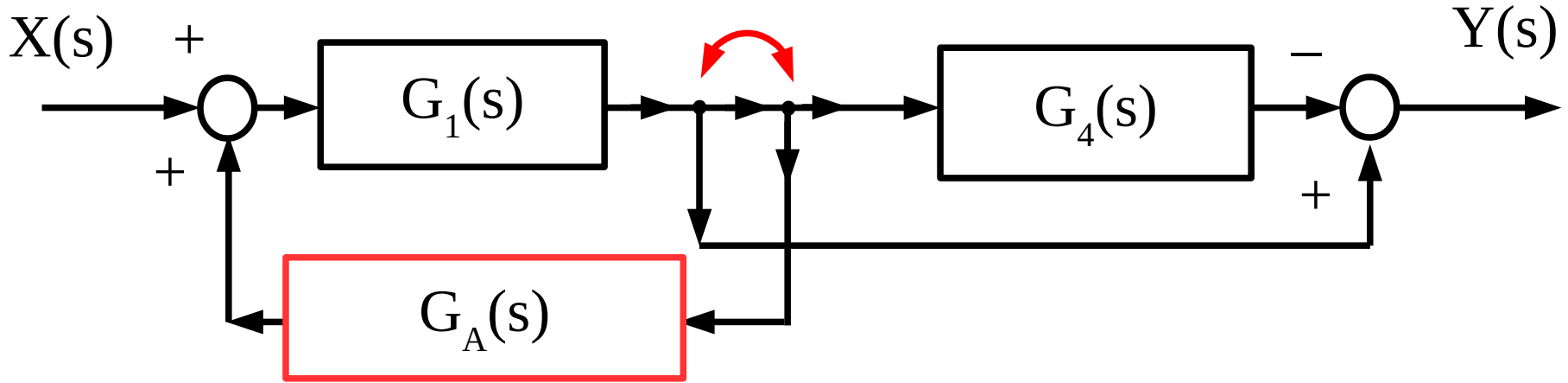

$$G_A = G_2 G_3$$

# EXAMPLE 2

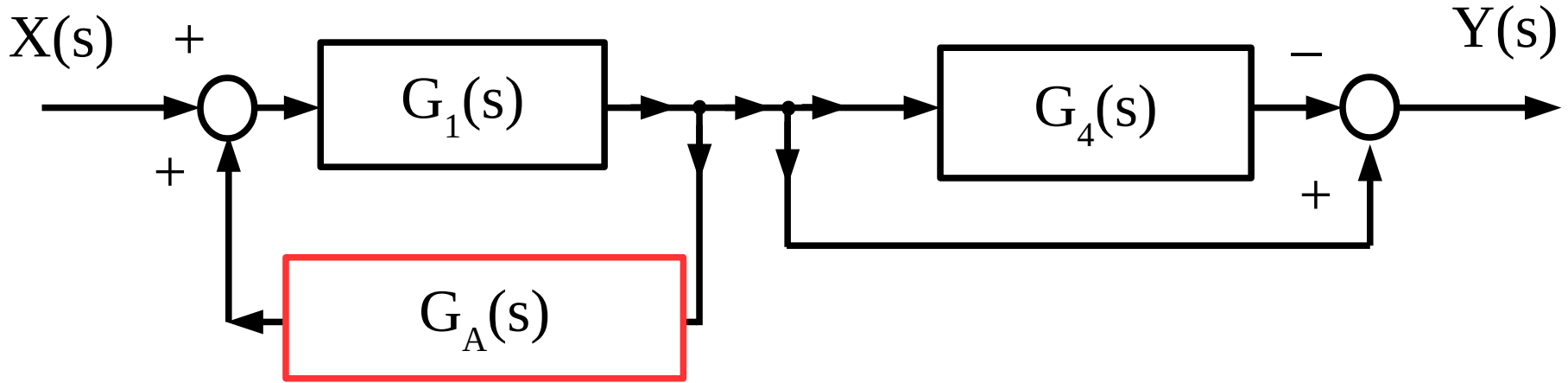



$$G_A = G_2 G_3$$

## EXAMPLE 2

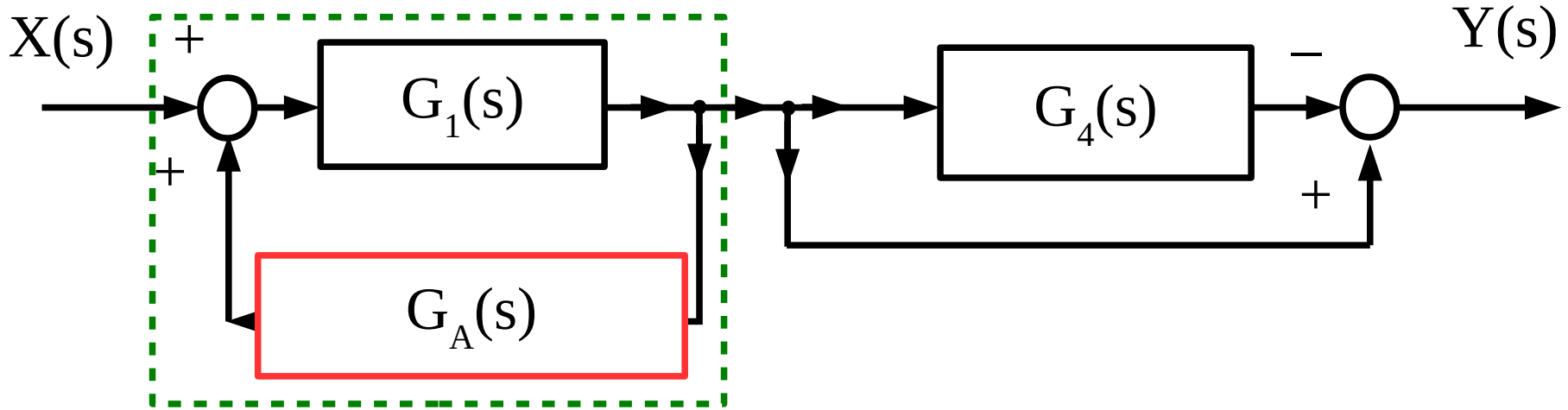

$$G_B = \frac{G_1}{1 - G_1 G_A}$$

$$G_A = G_2 G_3$$

$$G_B = \frac{G_1}{1 - G_1 G_A}$$

## EXAMPLE 2

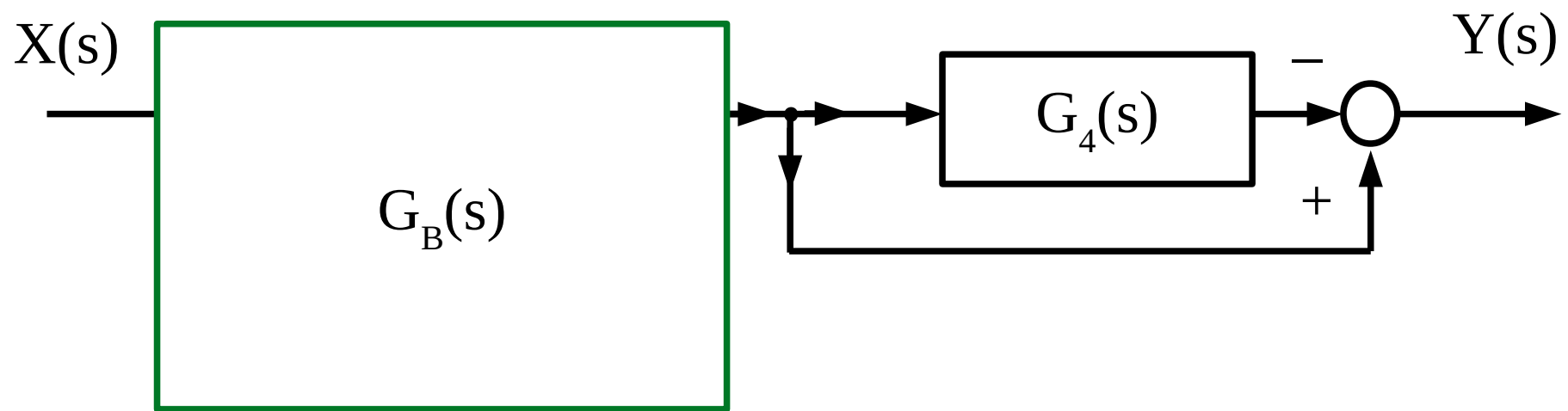

$$G_A = G_2 G_3$$

$$G_B = \frac{G_1}{1 - G_1 G_A}$$

## EXAMPLE 2

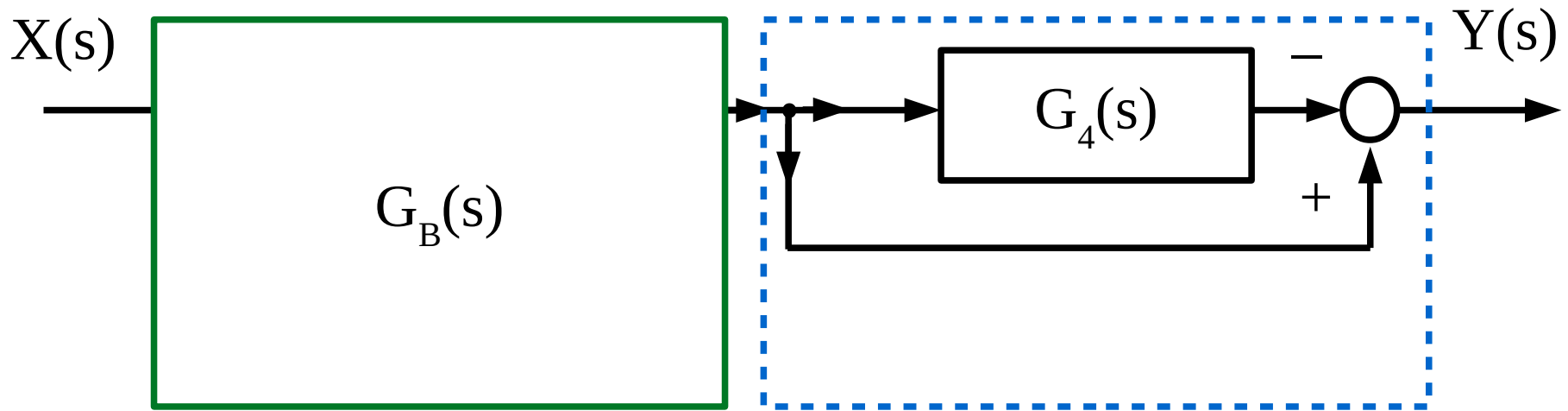

$$G_A = G_2 G_3$$

$$G_B = \frac{G_1}{1 - G_1 G_A}$$

## EXAMPLE 2

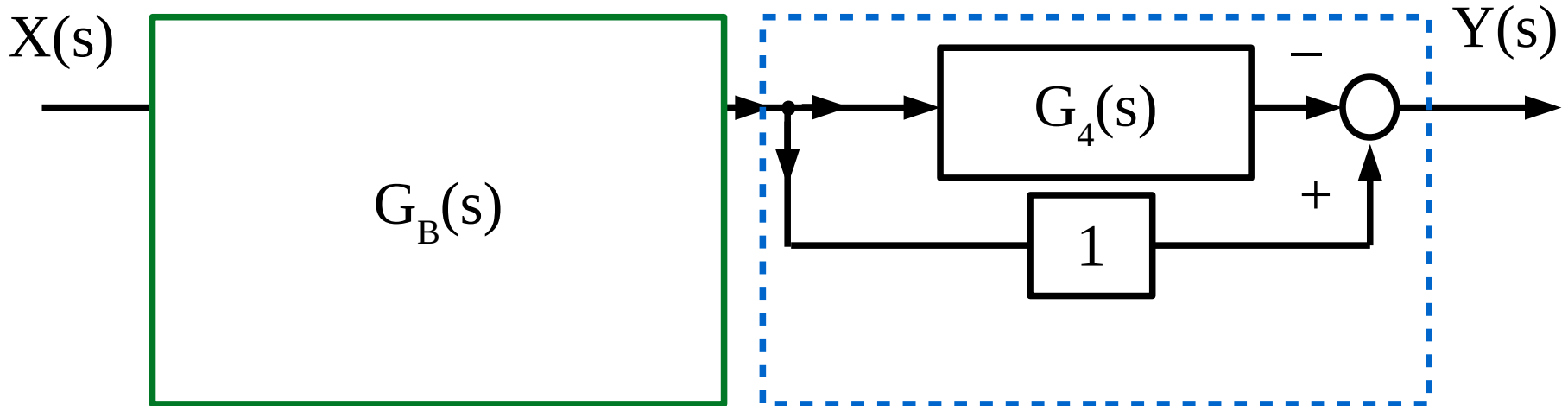

$$G_A = G_2 G_3$$

$$G_B = \frac{G_1}{1 - G_1 G_A}$$

## EXAMPLE 2

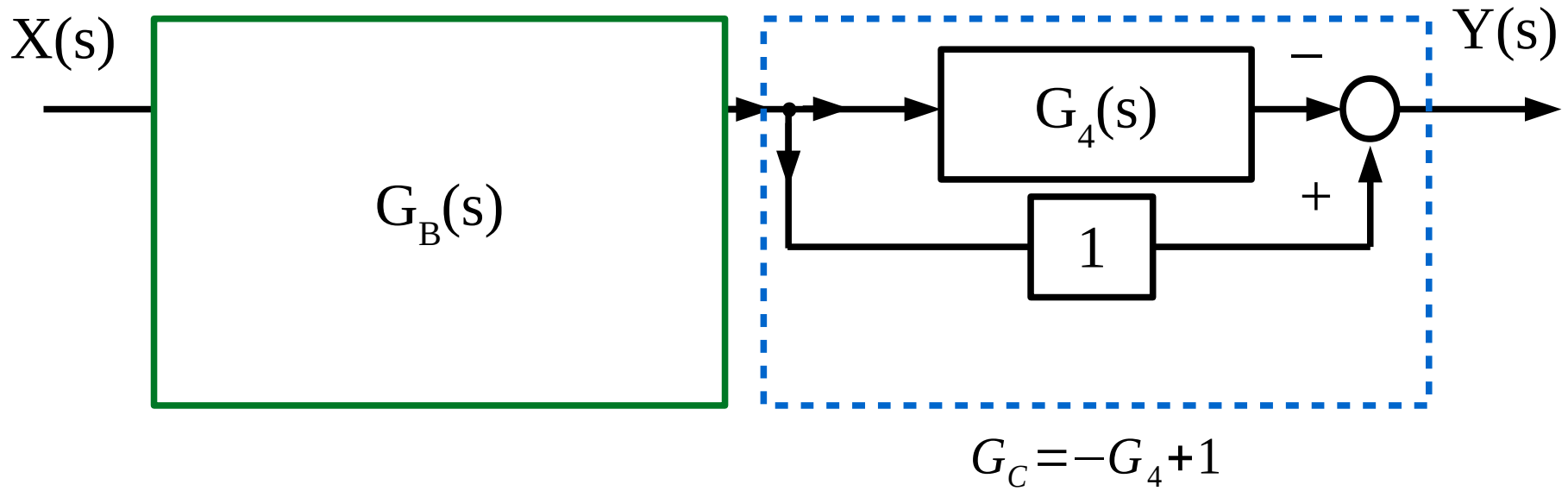

$$G_A = G_2 G_3$$

$$G_B = \frac{G_1}{1 - G_1 G_A}$$

$$G_C = -G_4 + 1$$

## EXAMPLE 2

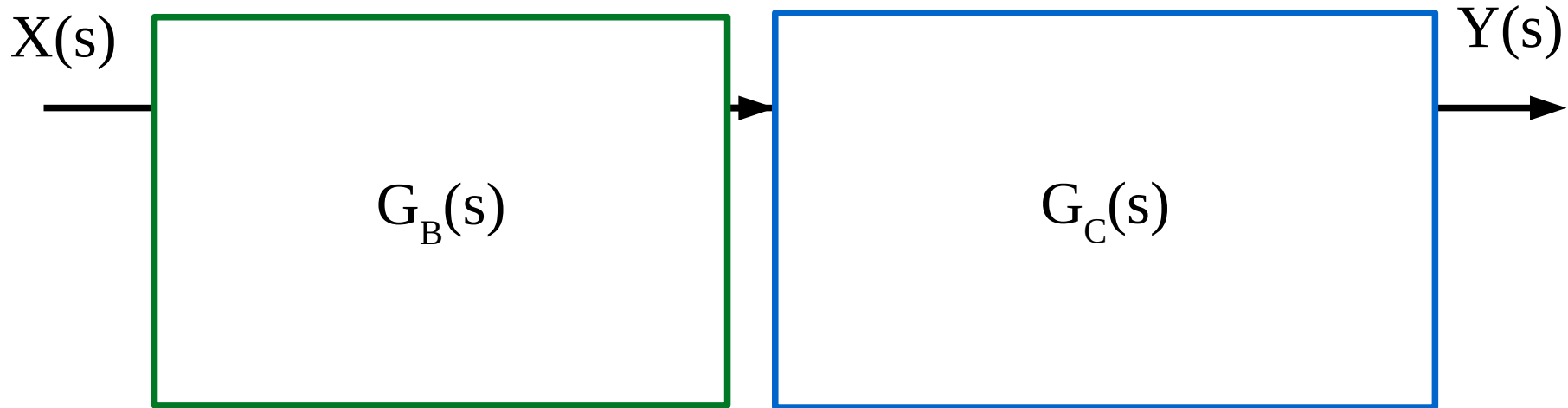

$$G_A = G_2 G_3$$

$$G_B = \frac{G_1}{1 - G_1 G_A}$$

$$G_C = -G_4 + 1$$

## EXAMPLE 2

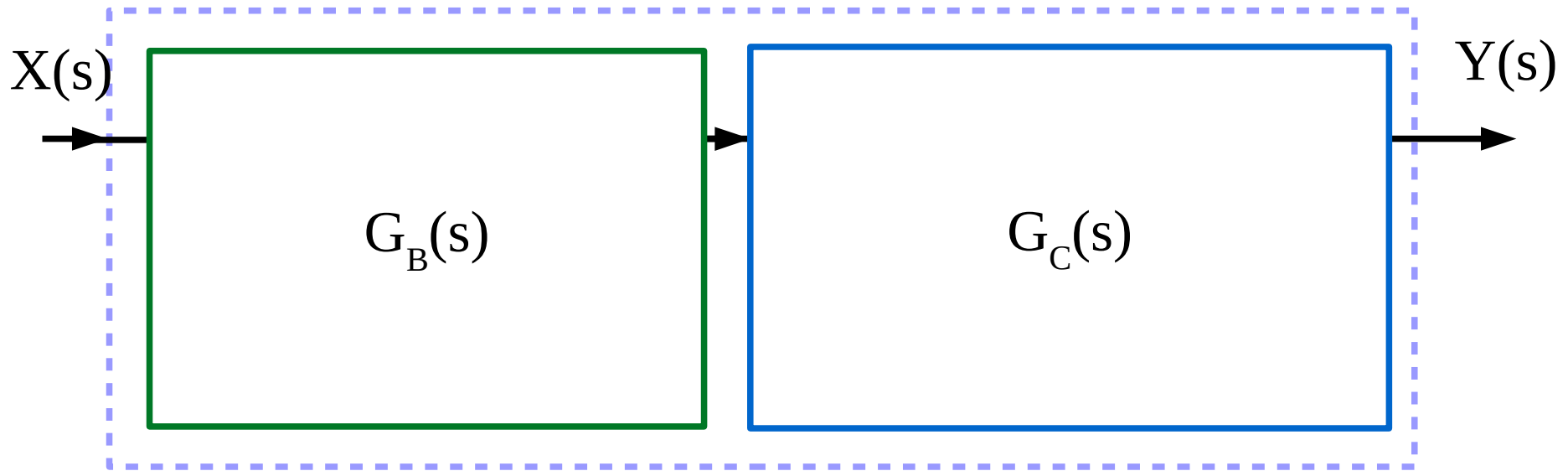

$$G_R = \frac{Y(s)}{X(s)} = G_B G_C$$

$$G_A = G_2 G_3$$

$$G_B = \frac{G_1}{1 - G_1 G_A}$$

$$G_C = -G_4 + 1$$

## EXAMPLE 2

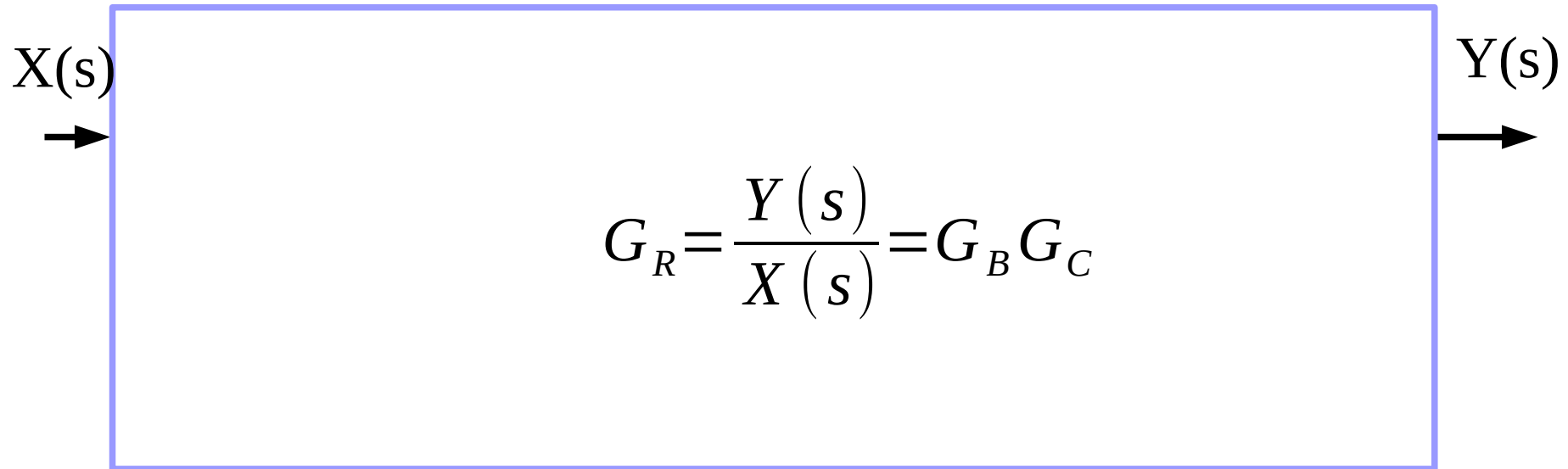



# BLOCK DIAGRAM ALGEBRA

## order change of sum node and block

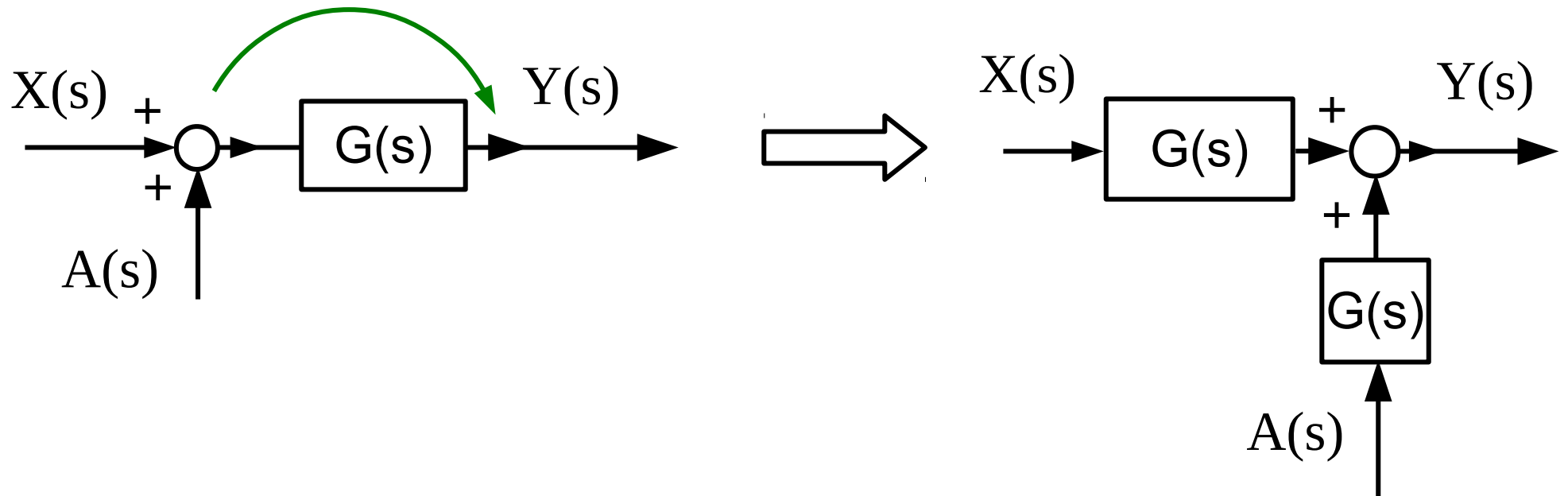

$$Y=(X+A)G$$

$$Y=XG+AG$$

# BLOCK DIAGRAM ALGEBRA

## order change of sum nodes

Example 1

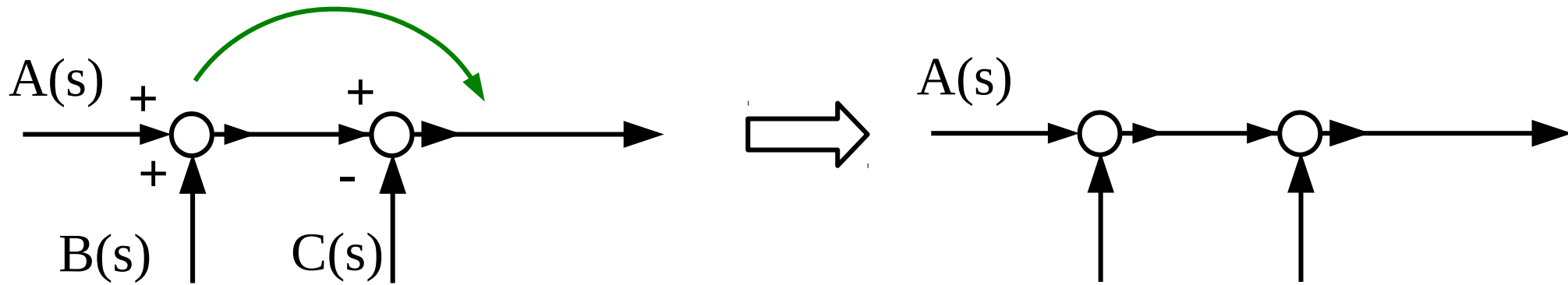

# BLOCK DIAGRAM ALGEBRA

## order change of sum nodes

Example 1

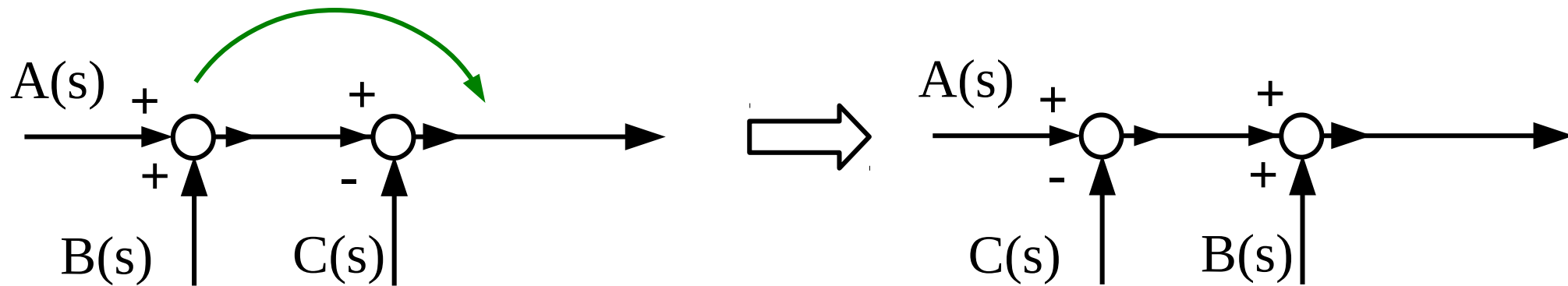

# BLOCK DIAGRAM ALGEBRA

## order change of sum nodes

### Example 2

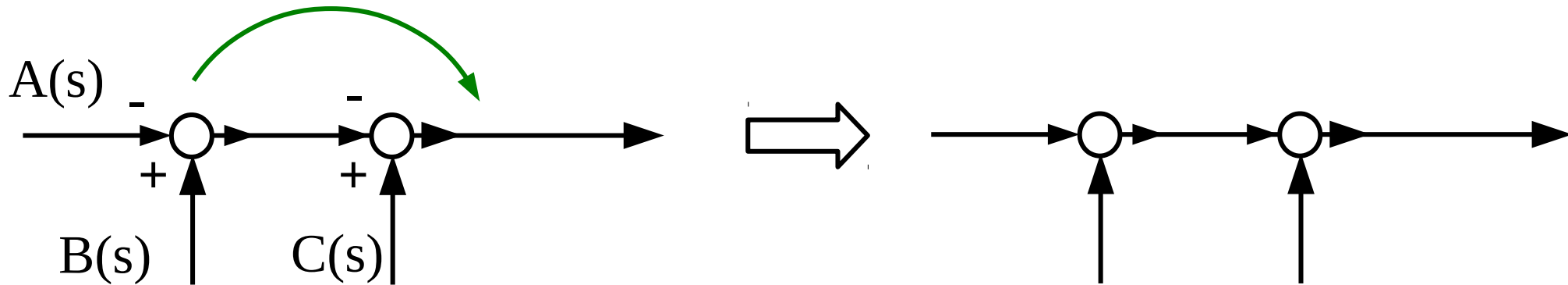

# BLOCK DIAGRAM ALGEBRA

## order change of sum nodes

Example 2 – attention to signs!

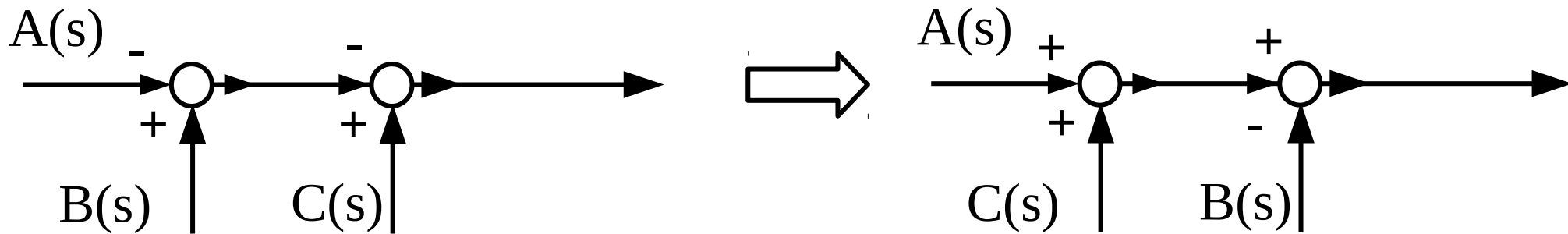

# BLOCK DIAGRAM ALGEBRA

## order change of block and information node

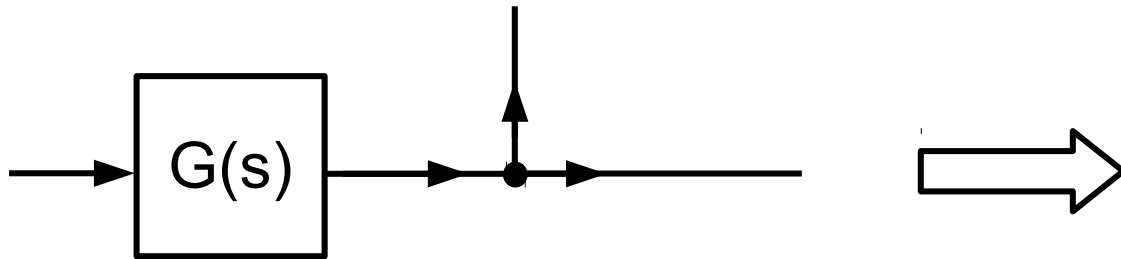

# BLOCK DIAGRAM ALGEBRA

## order change of block and information node

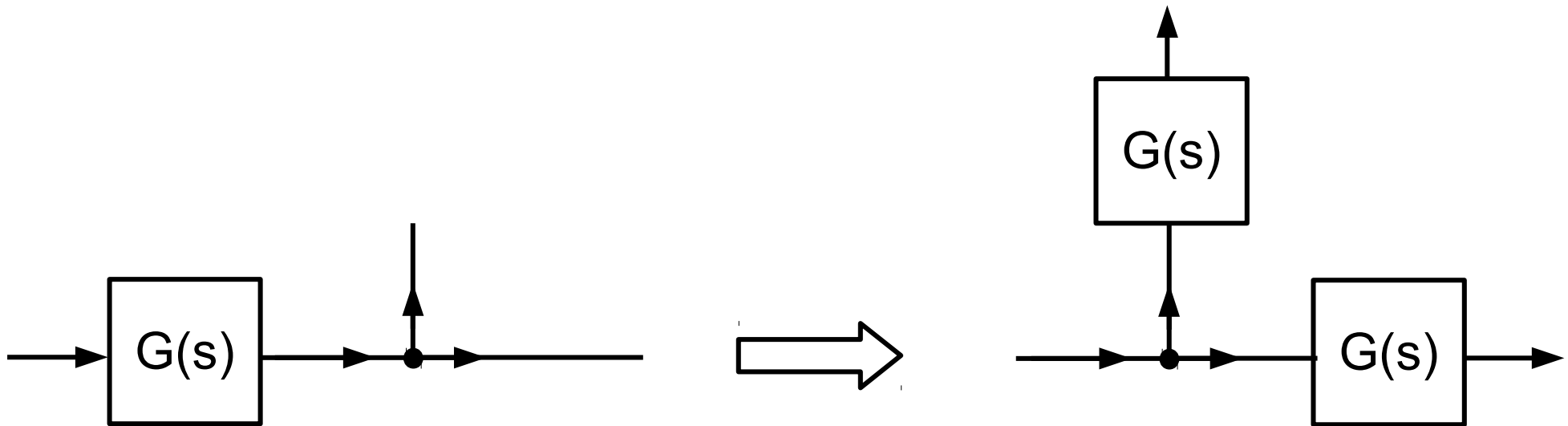

# EXAMPLE 3

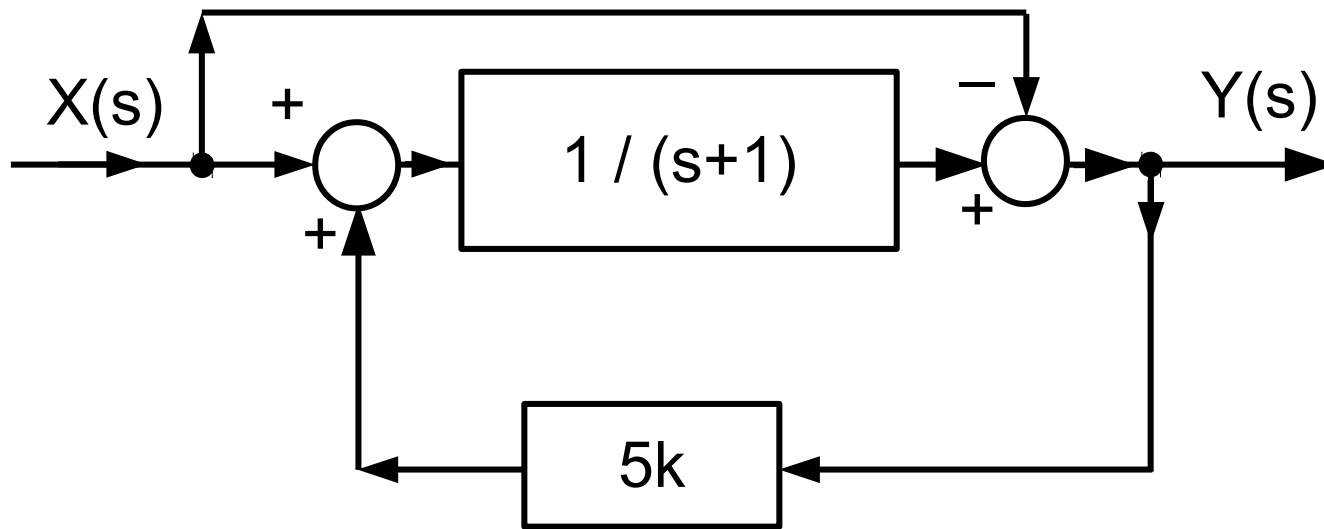



# EXAMPLE 3

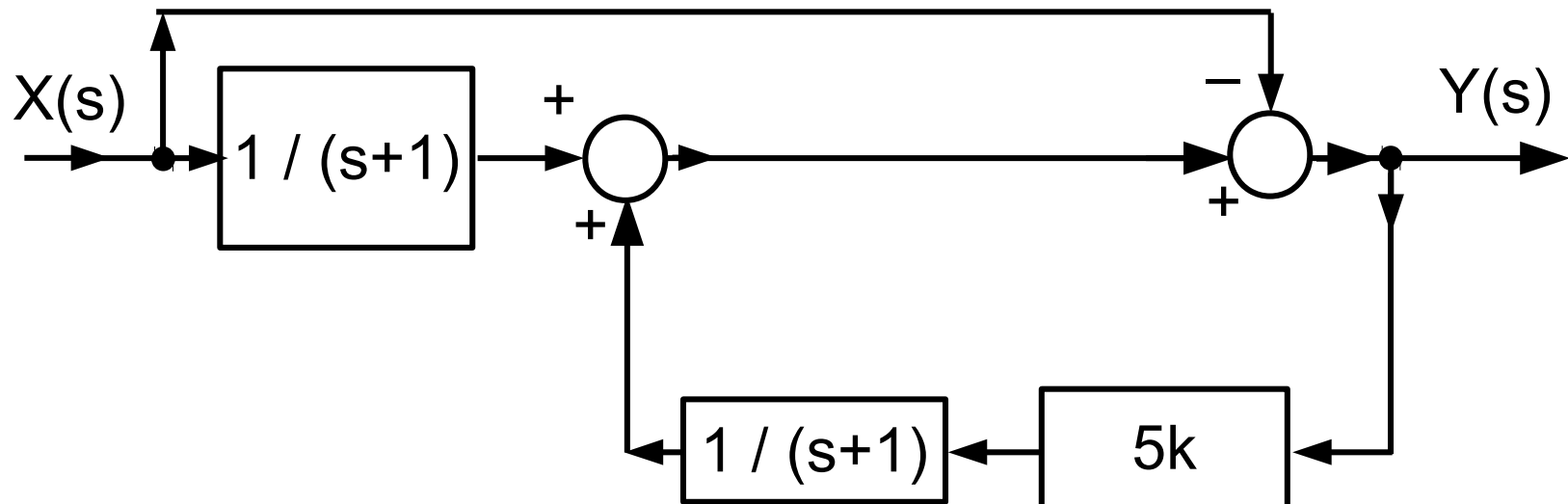
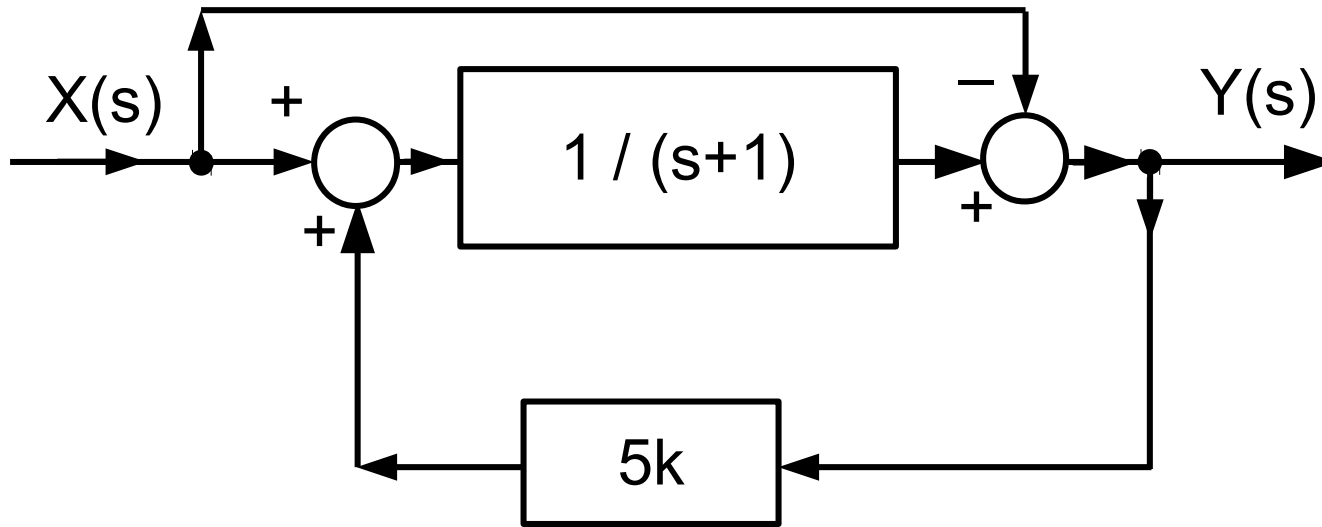

# EXAMPLE 3

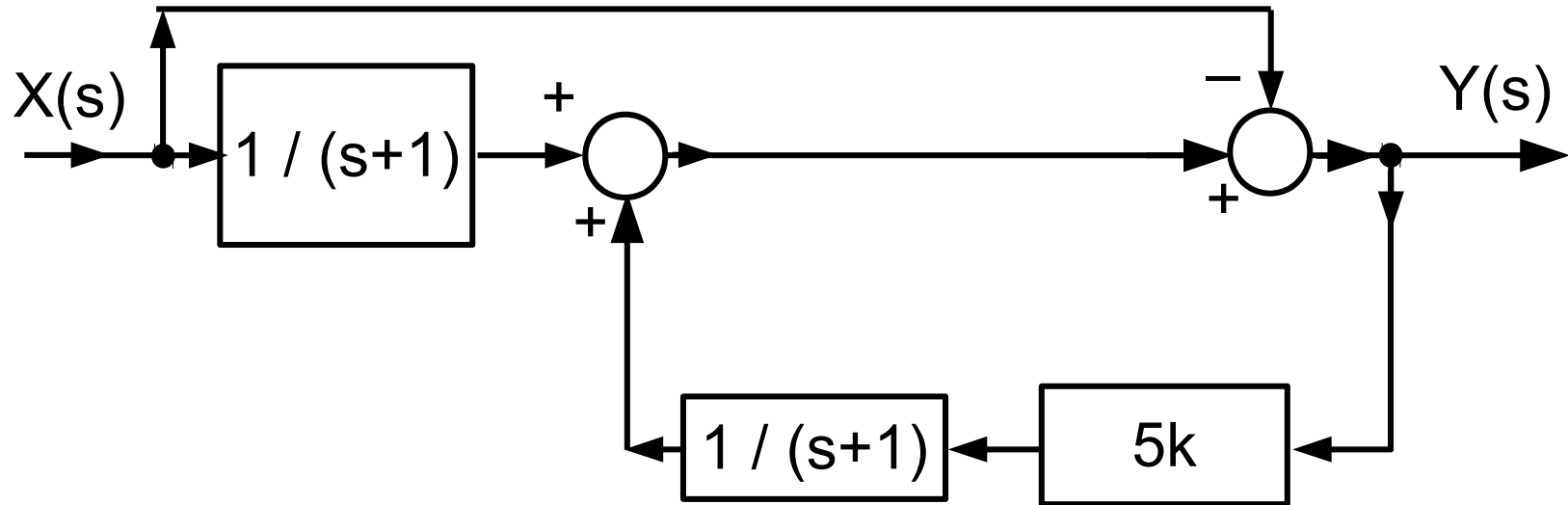

# EXAMPLE 3

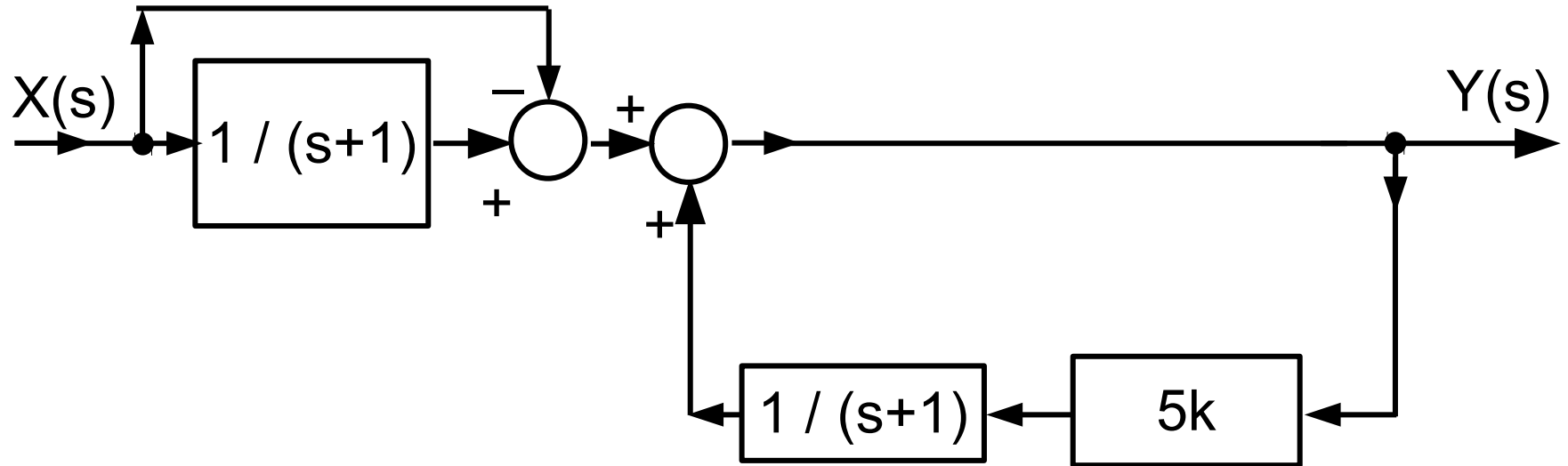

# EXAMPLE 3

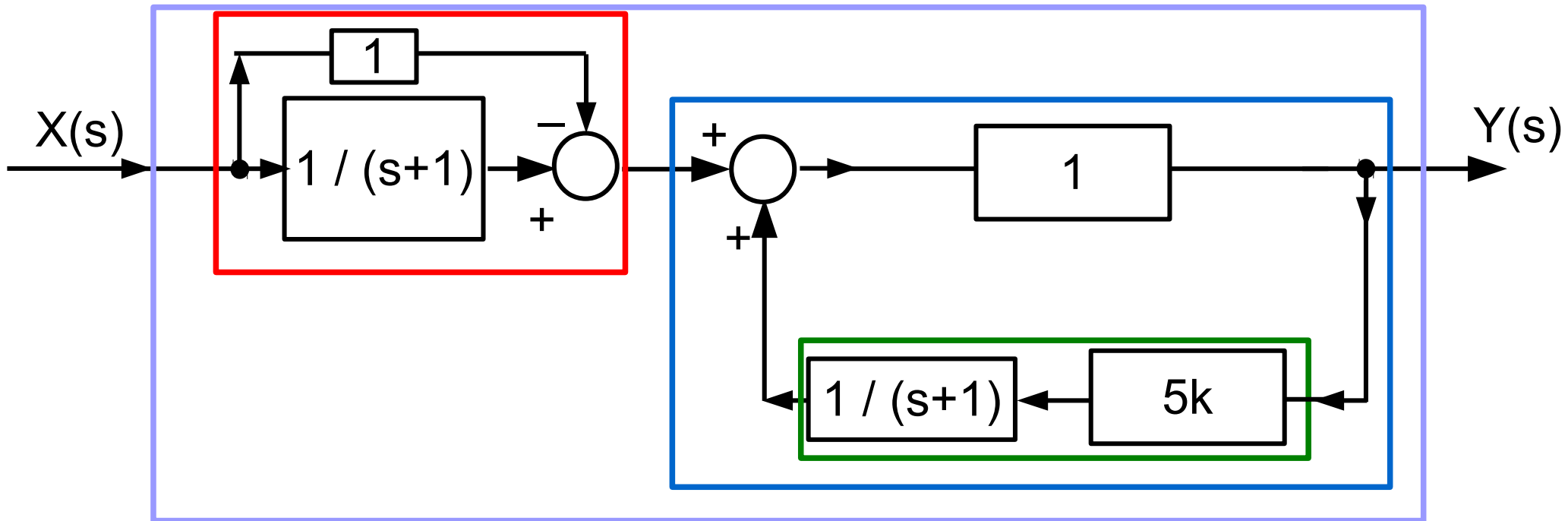

# EXAMPLE 4

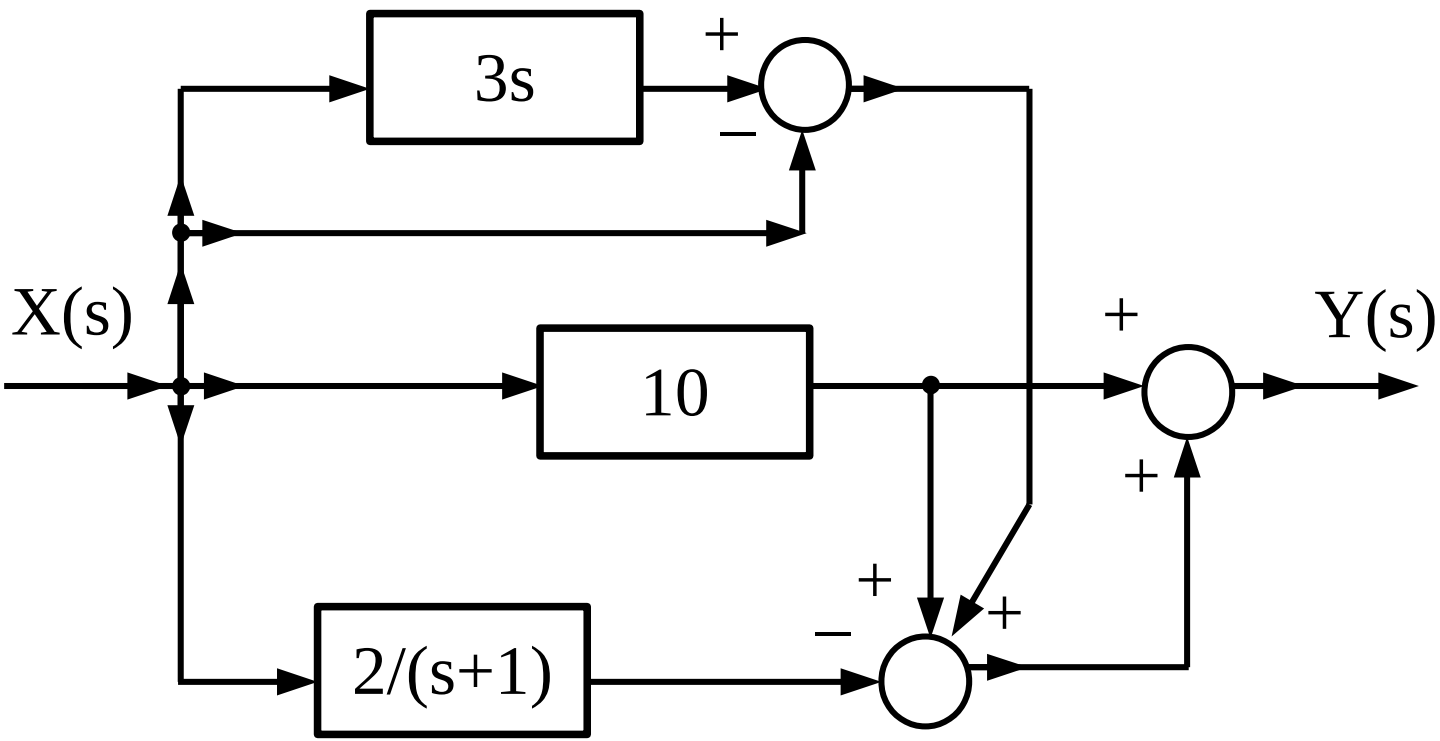

# EXAMPLE 4

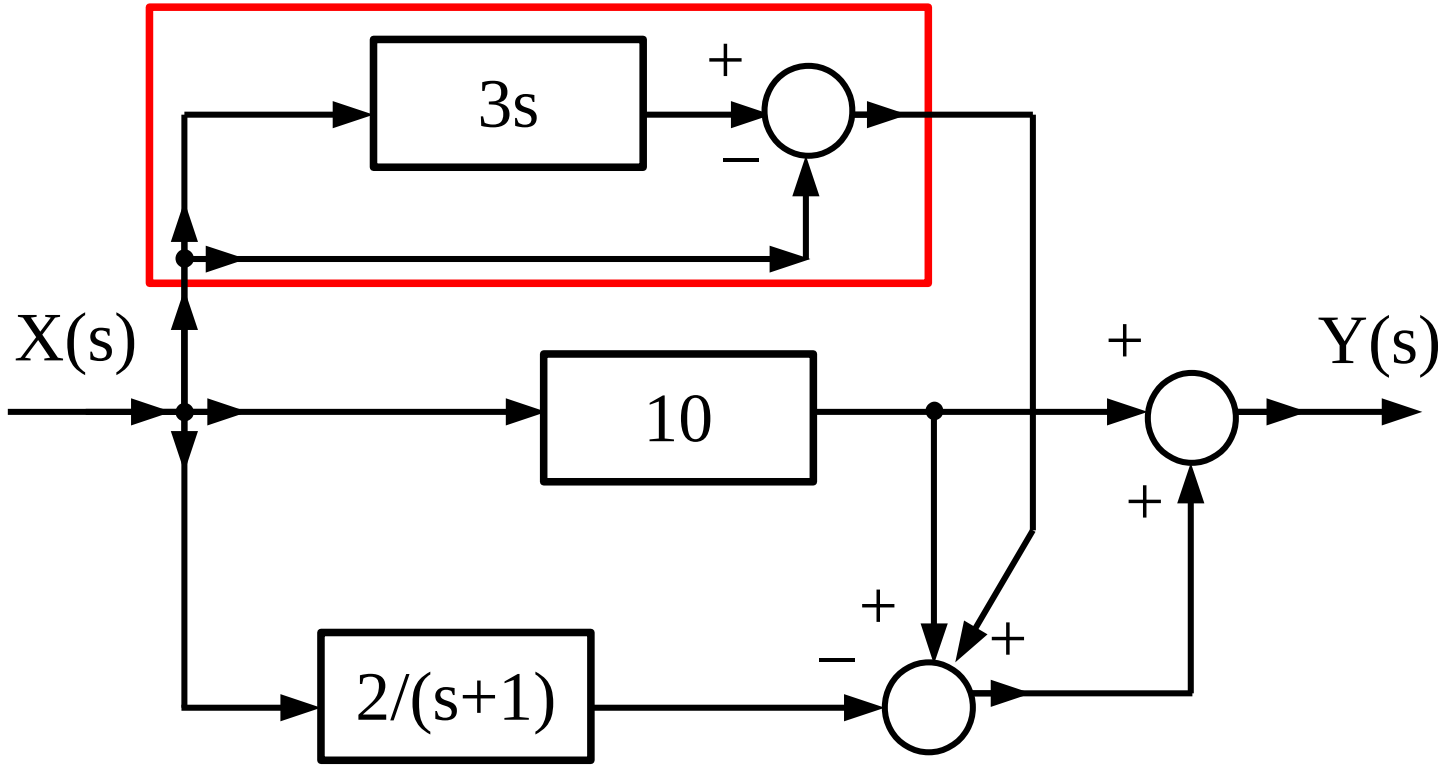

# EXAMPLE 4

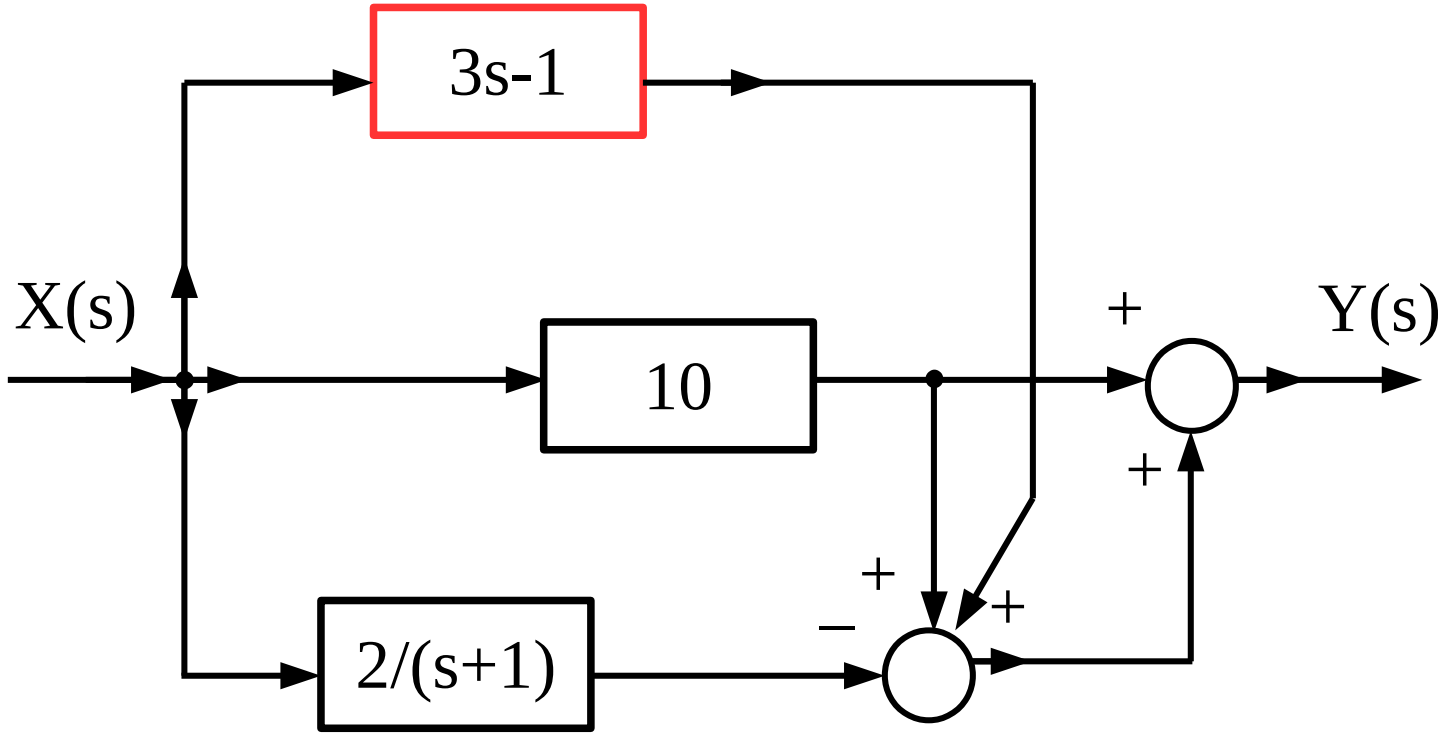

# EXAMPLE 4

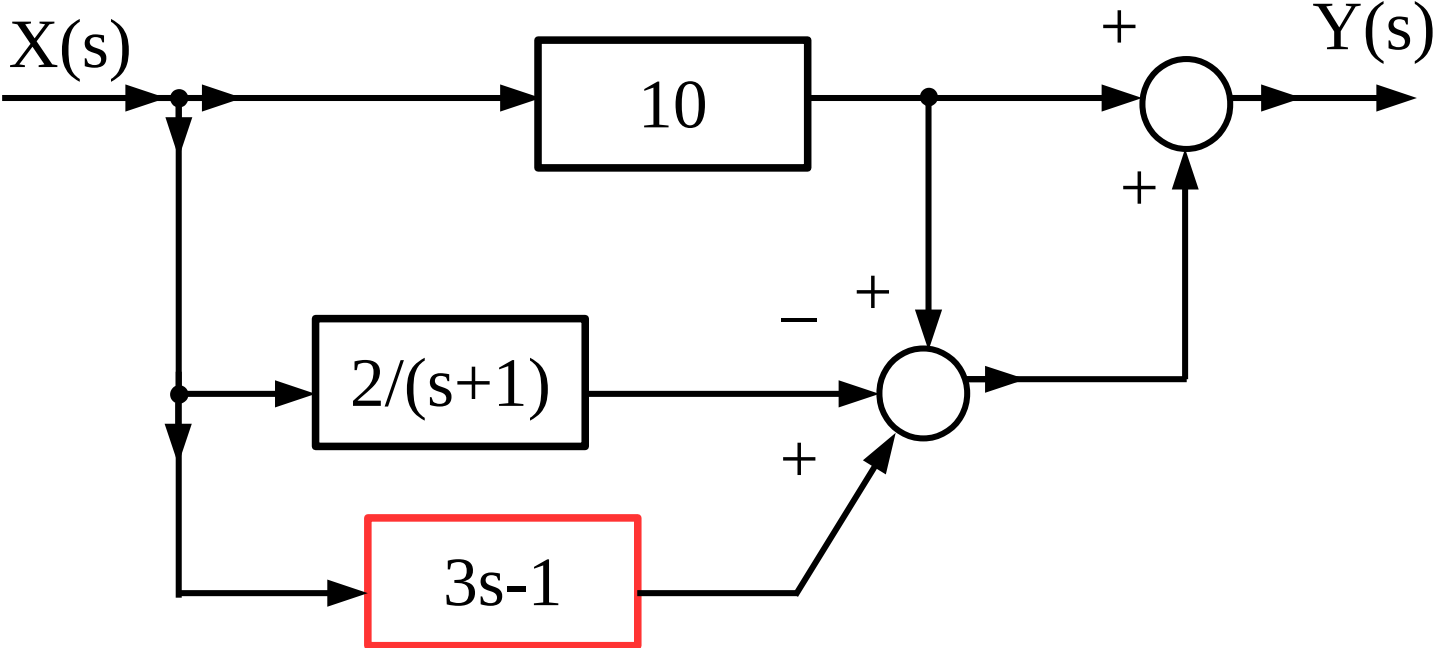



# EXAMPLE 4

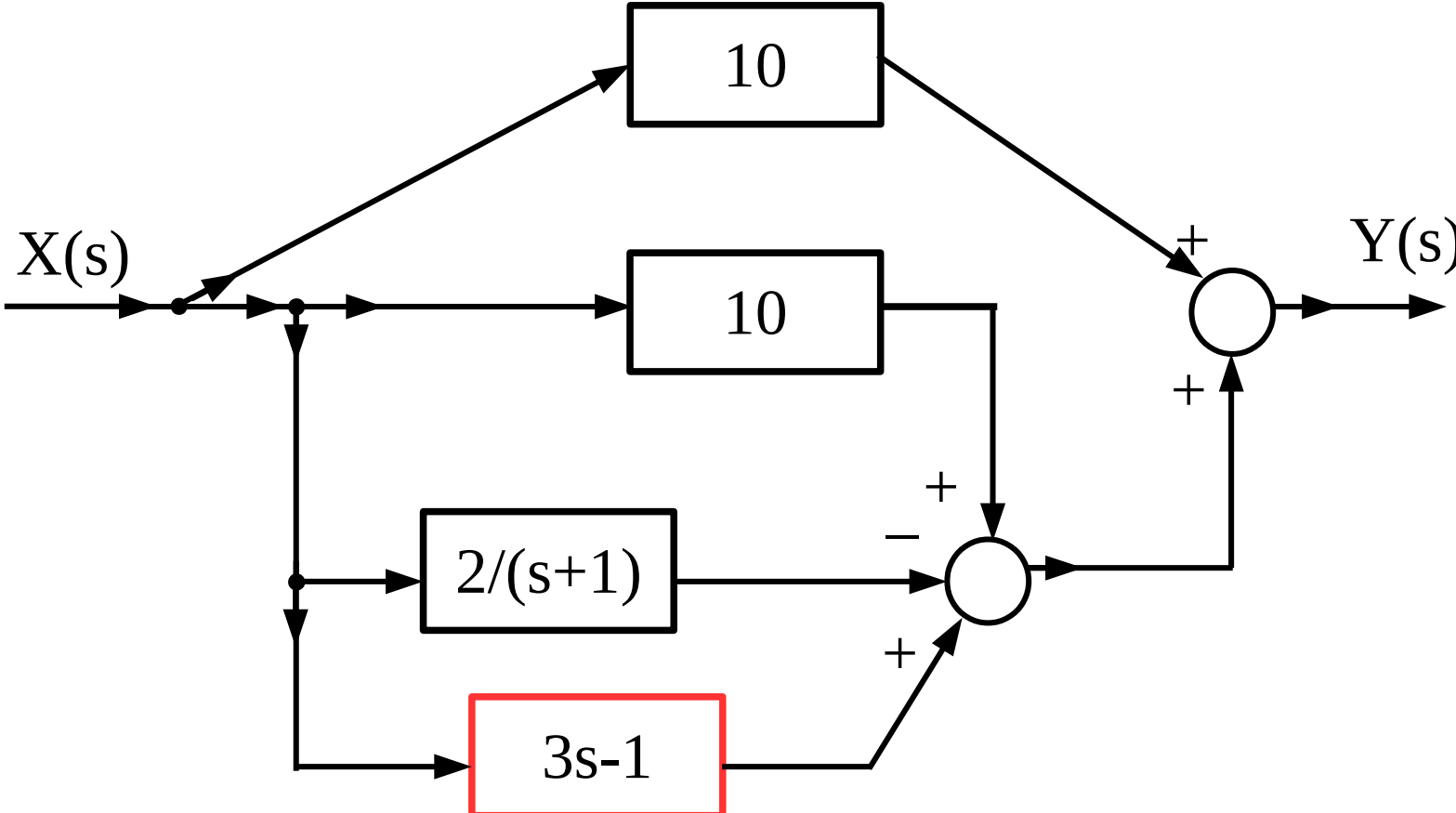

# EXAMPLE 4

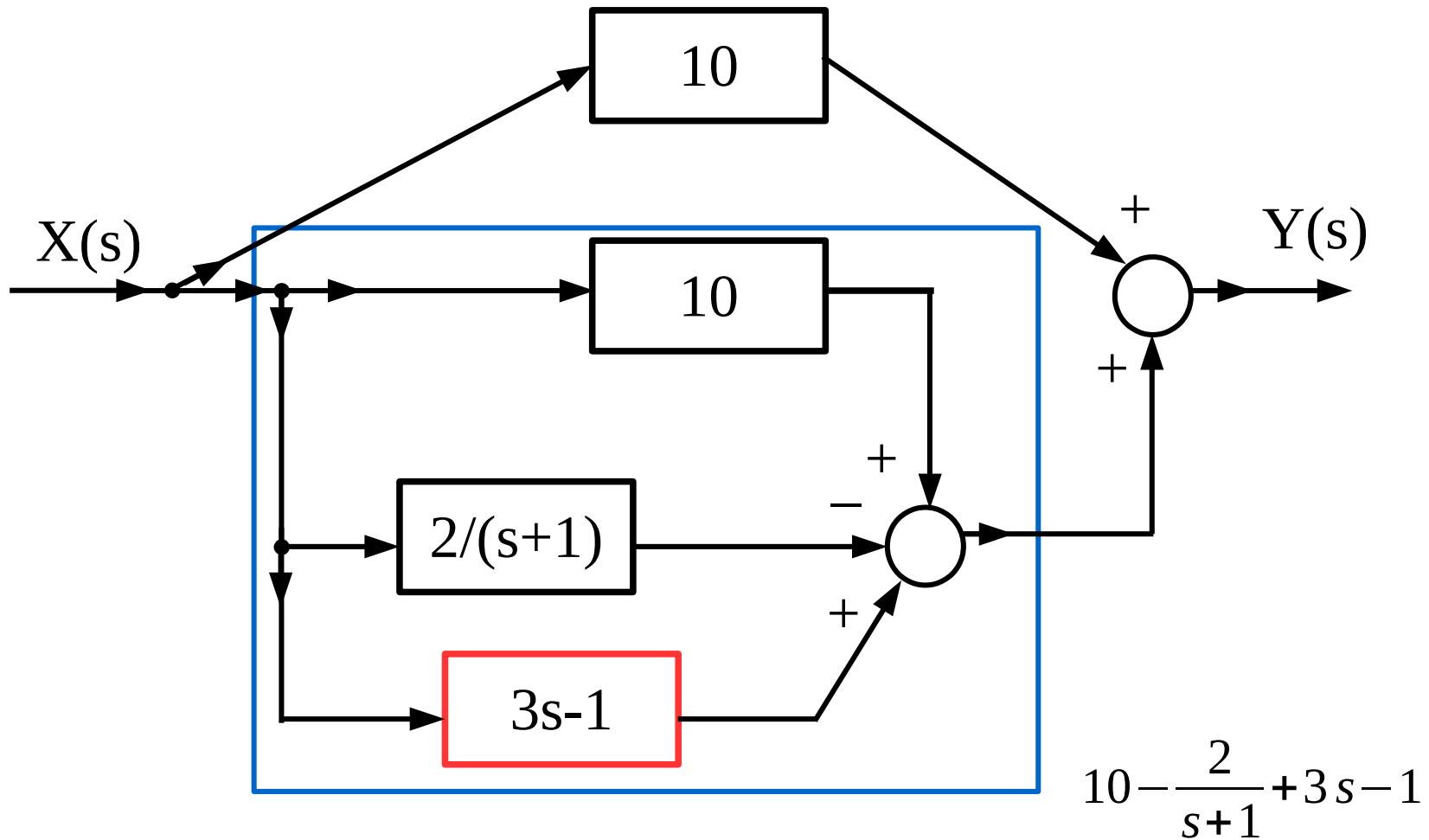

# EXAMPLE 4

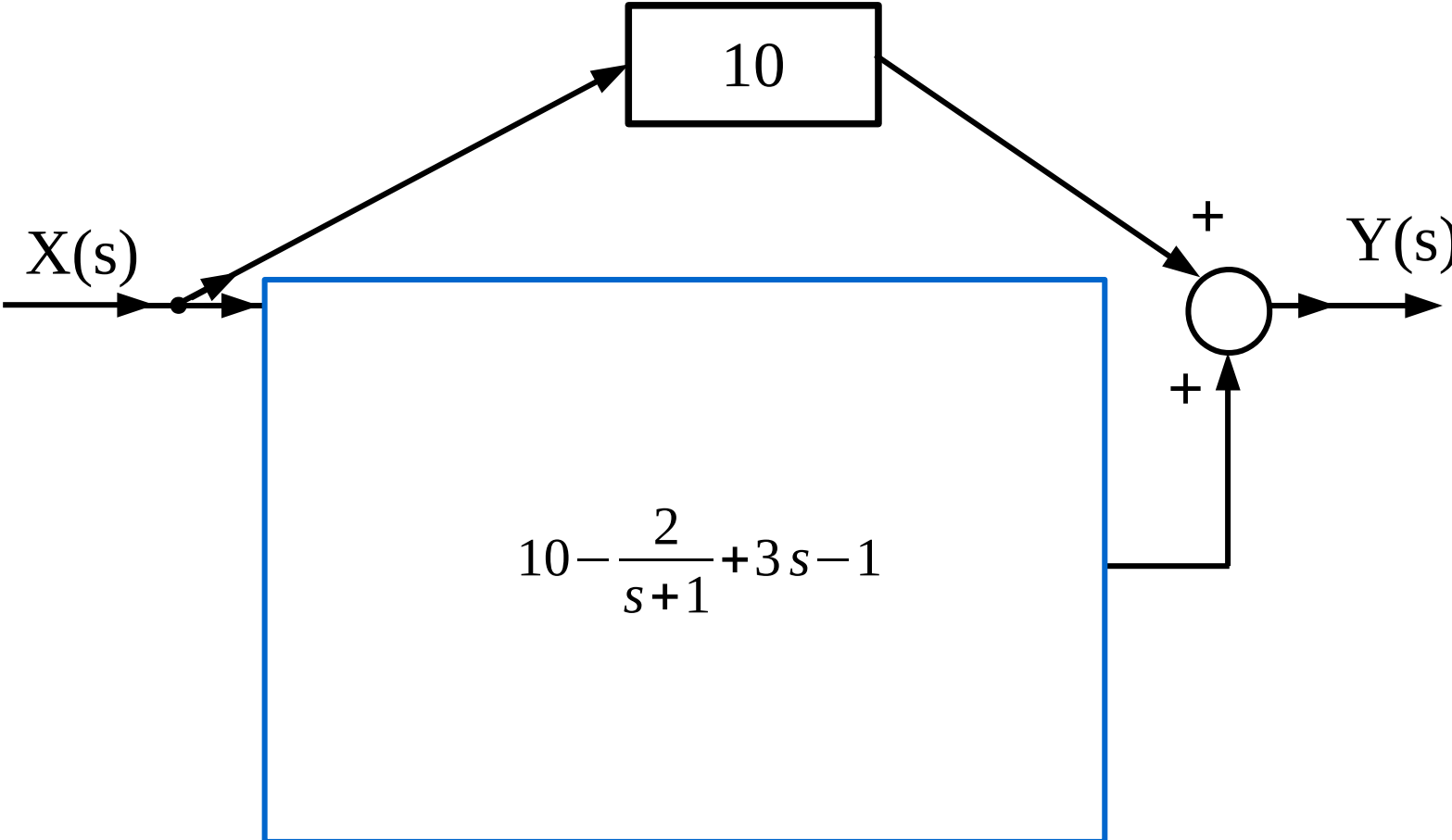

# EXAMPLE 4

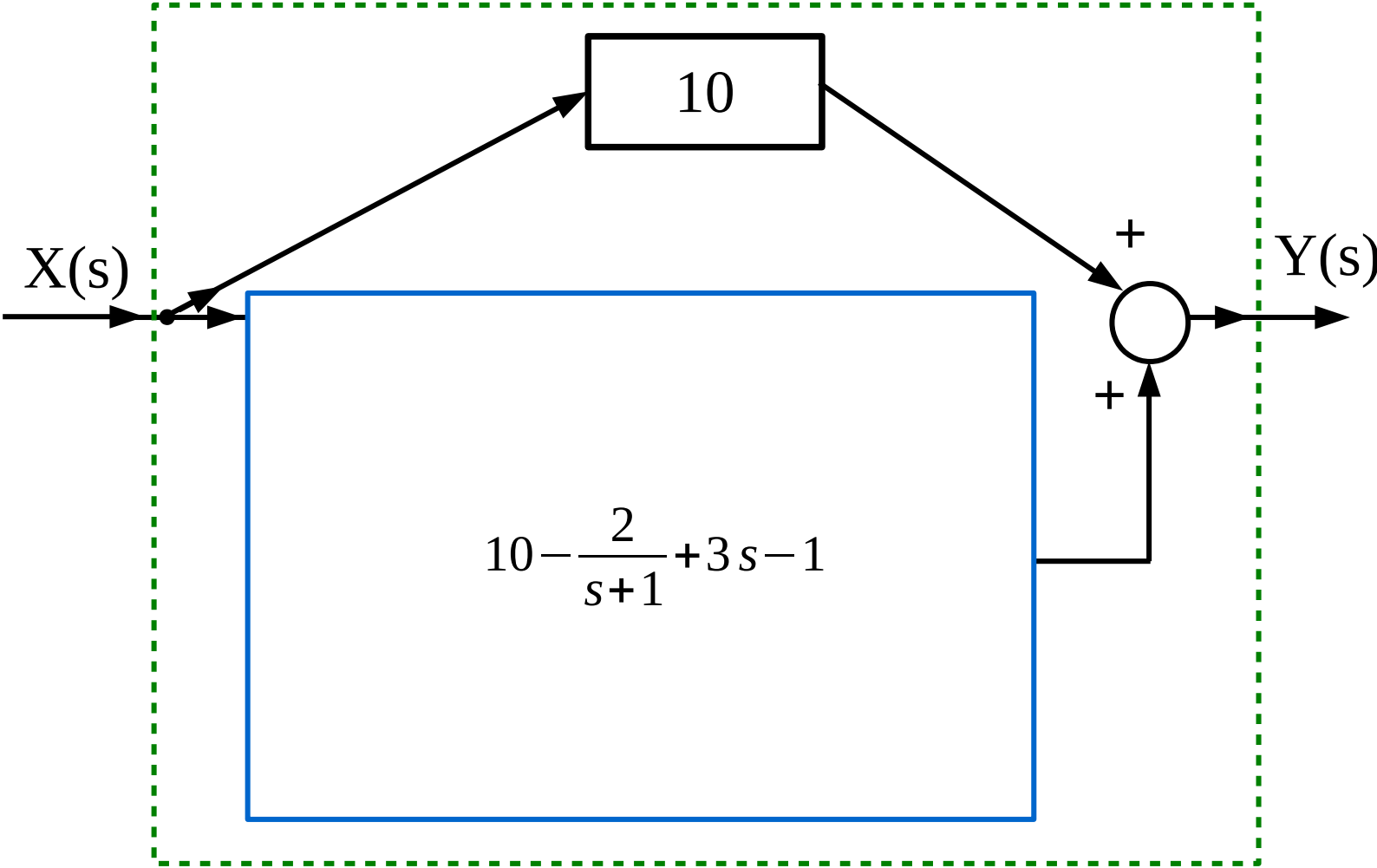

# EXAMPLE 4

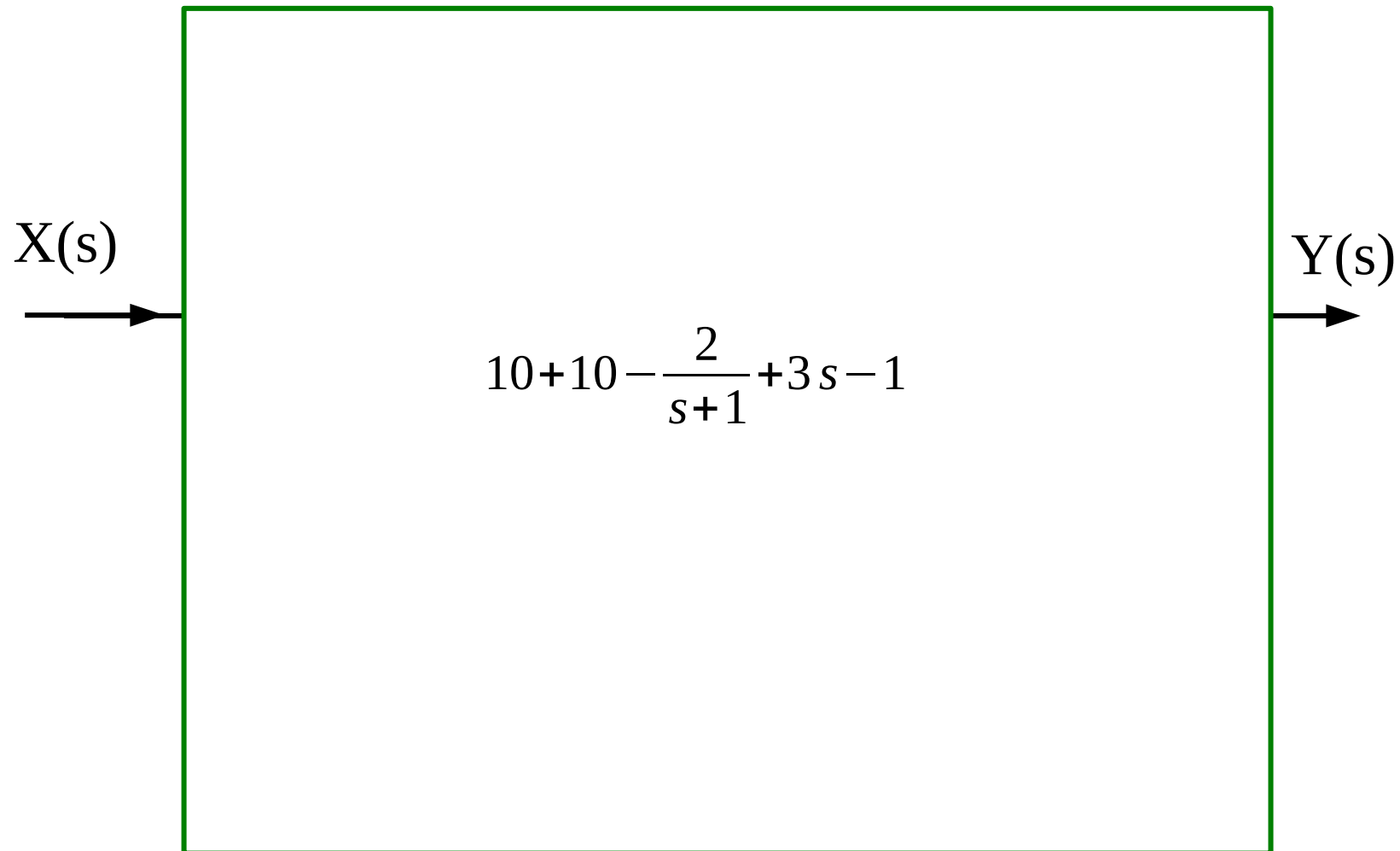

# EXAMPLE 4

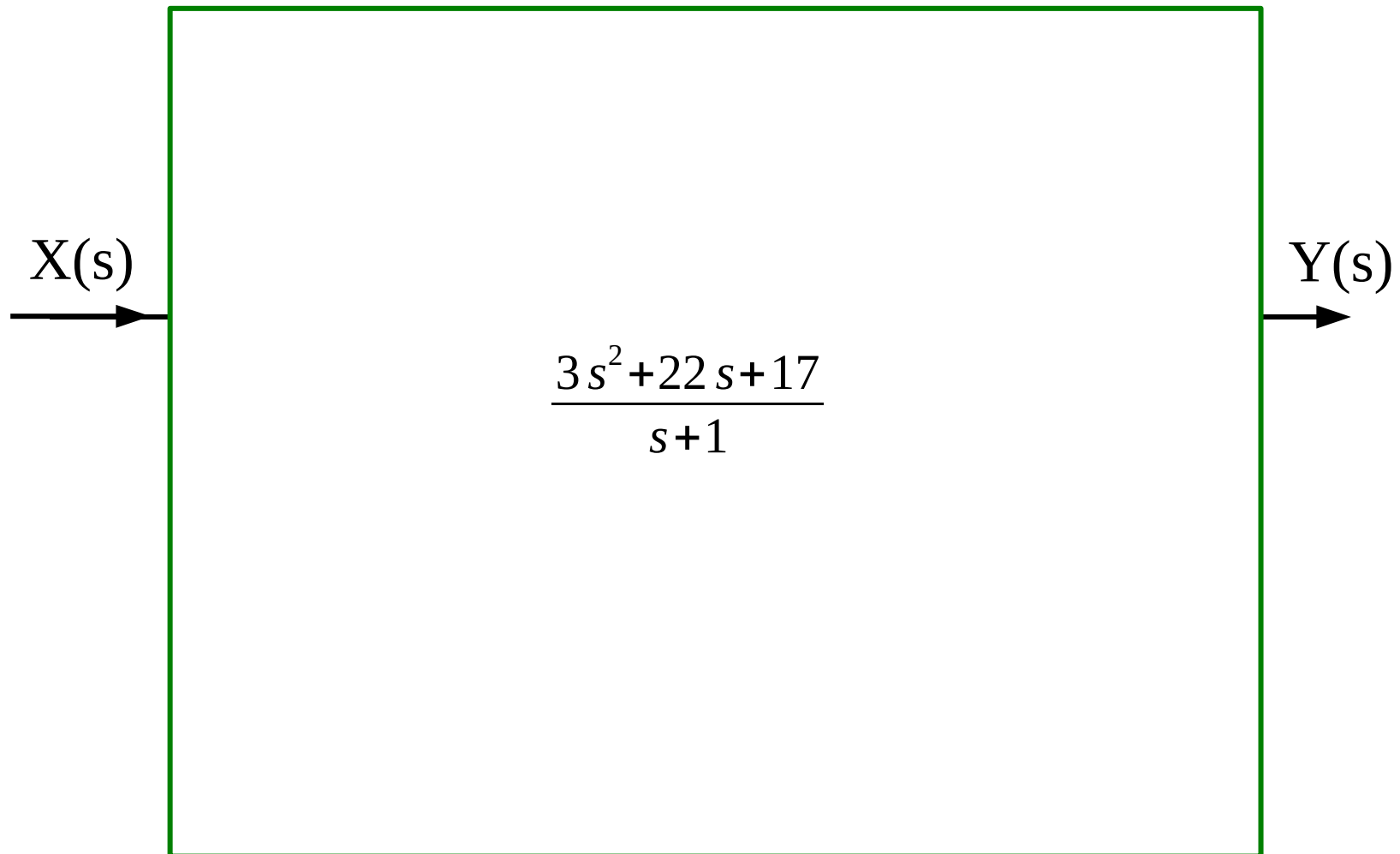

# CONTROLLERS

# Closed loop control

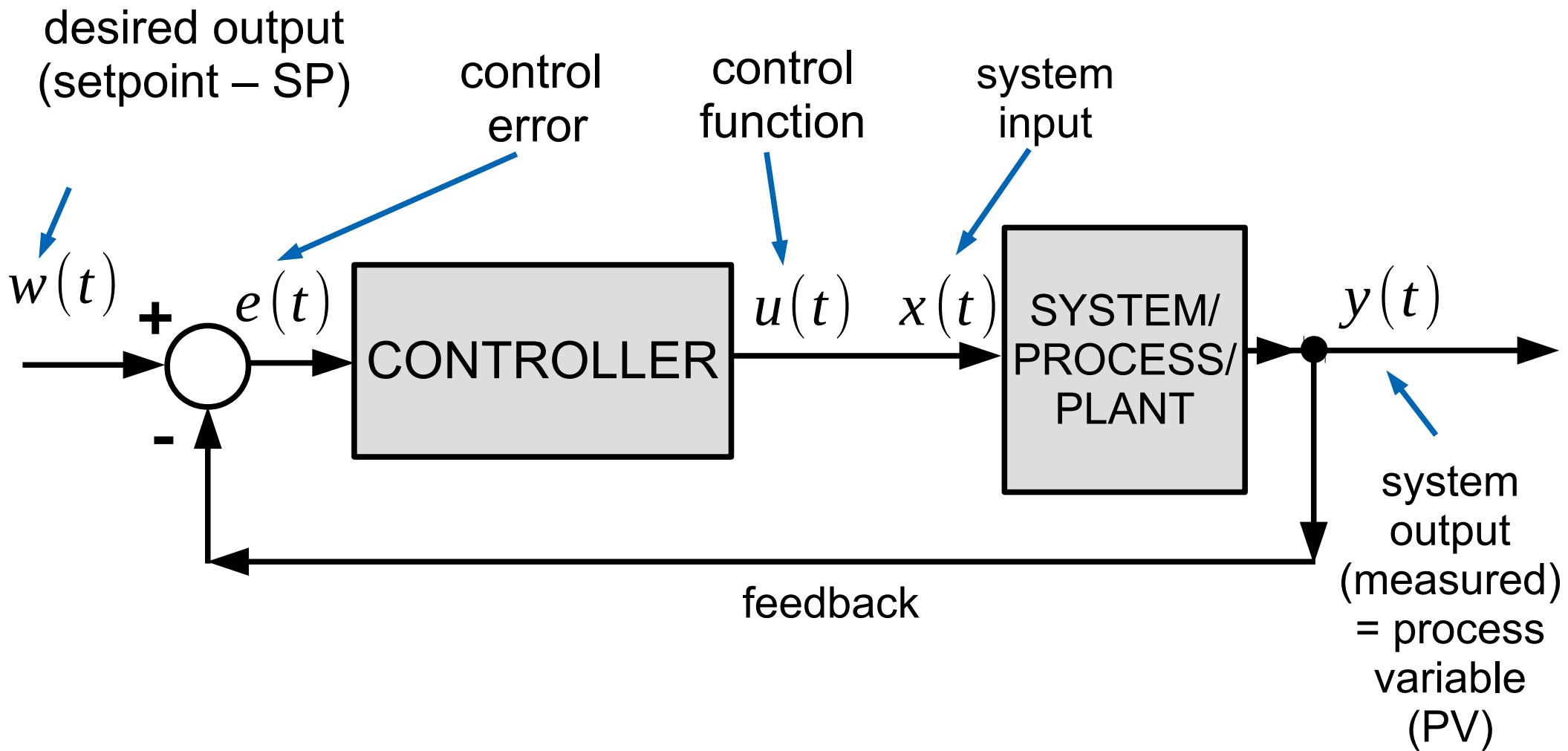



# Types of controllers

- two state (ON/OFF)
  - three state
- Proportional (P)
- Integrator (I)
- Differentiator (D)
- Proportional-integral-derivative (PID)



# ON-OFF CONTROLLER (RELAY / TWO STATE / BANG-BANG)

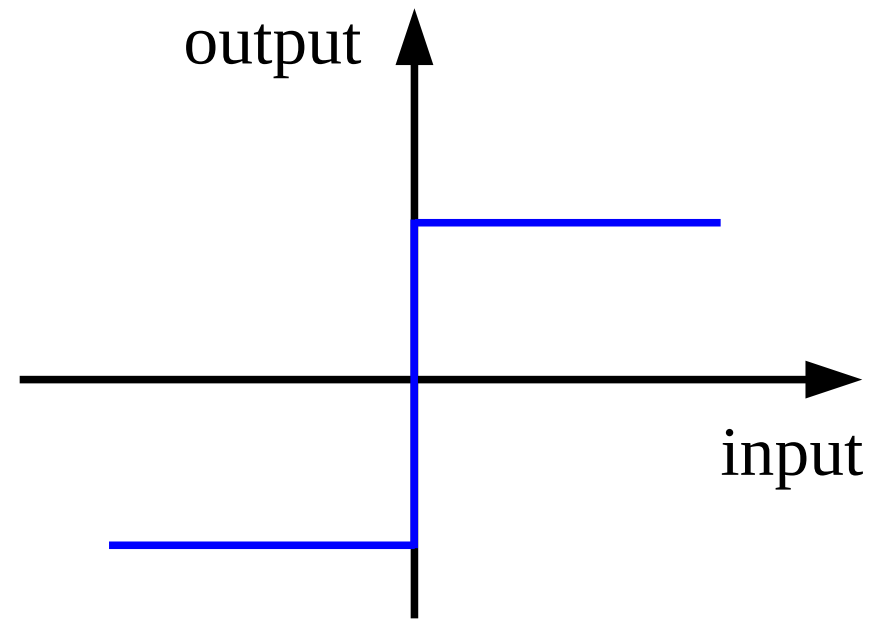
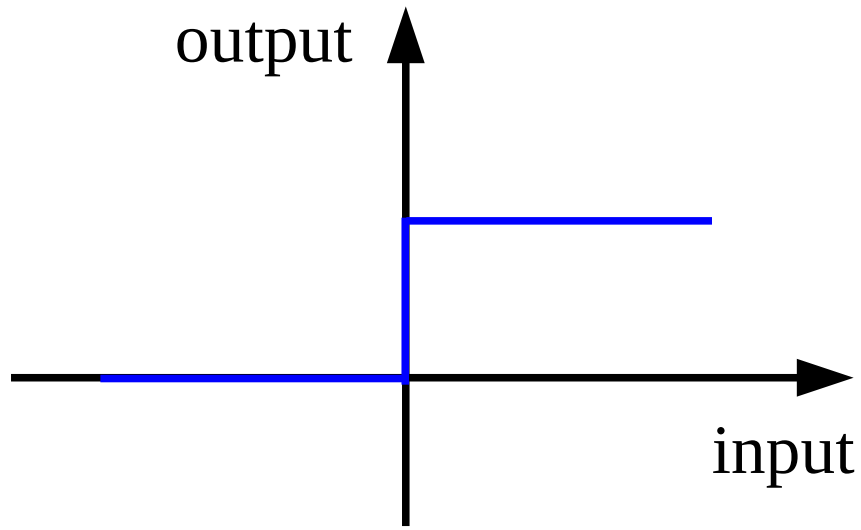

# ON-OFF CONTROLLER (RELAY / TWO STATE / BANG-BANG)

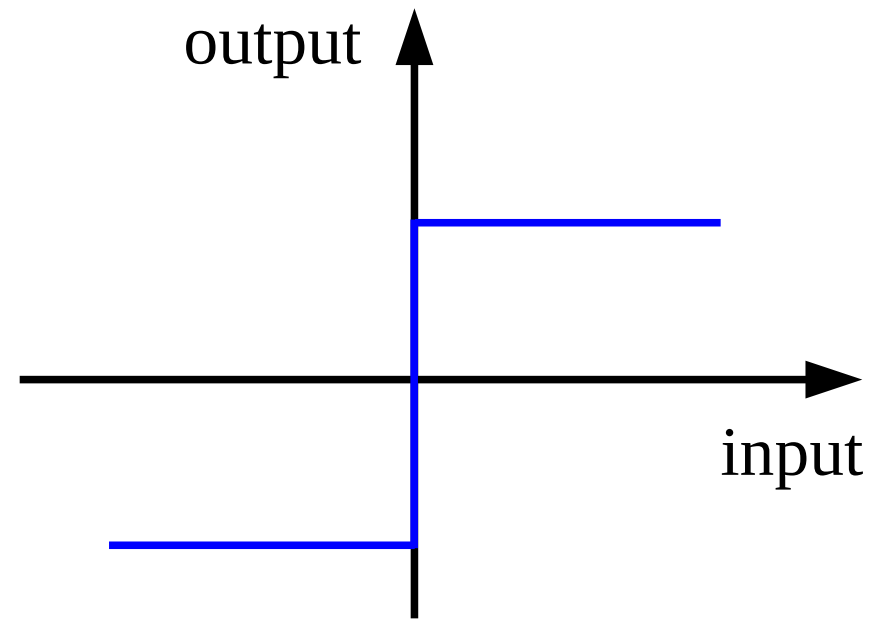
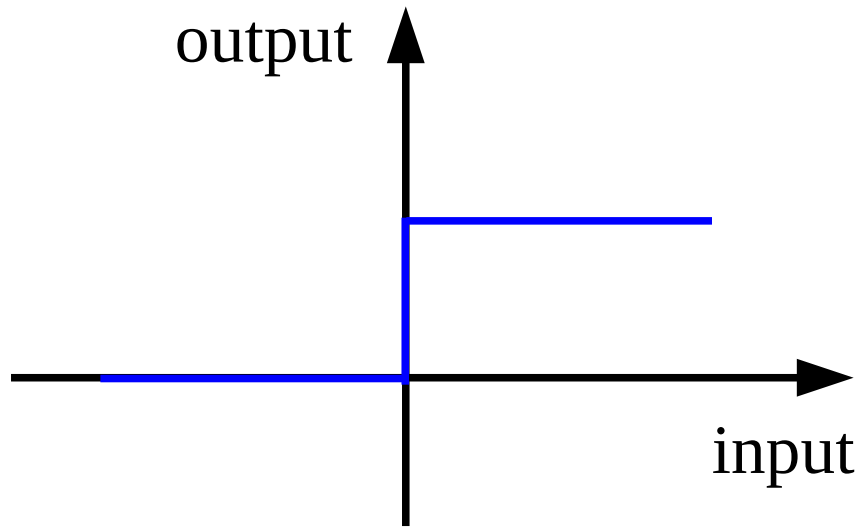

real  
(with hysteresis)

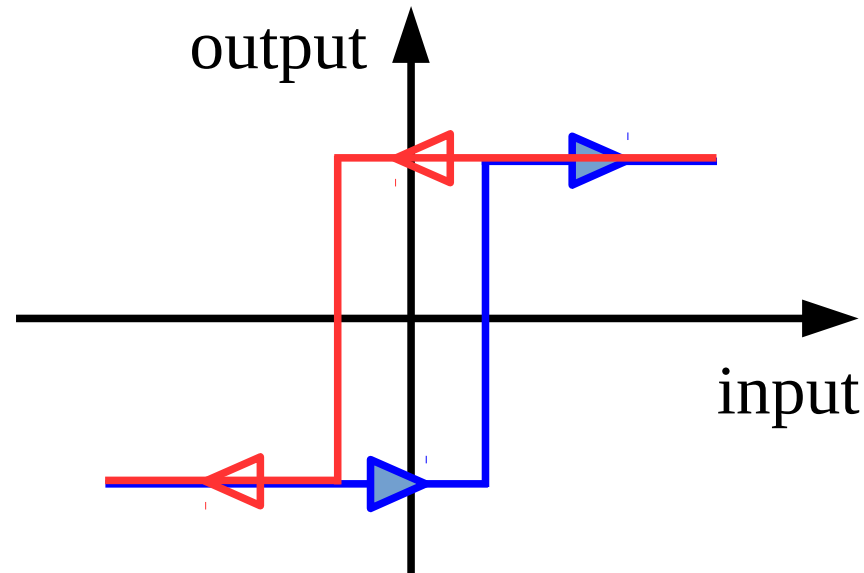

# ON-OFF CONTROLLER (RELAY / TWO STATE / BANG-BANG)

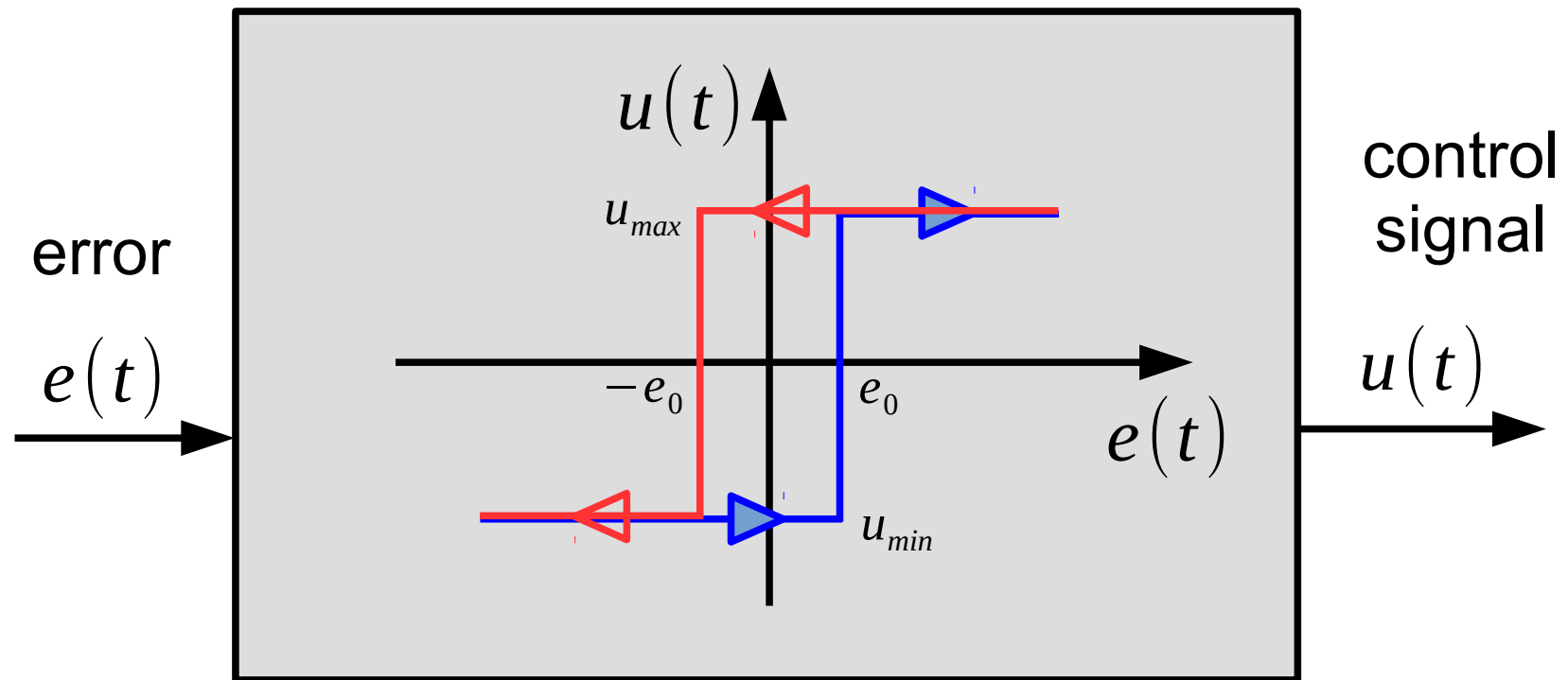

$$u(t) = \left\{ \begin{array}{l} u_{max}, \text{ if } e > e_0 \\ u_{min}, \text{ if } e < -e_0 \\ \text{no change, in other situations} \end{array} \right\}$$

$e_0$  - mechanical or programmed hysteresis

# ON-OFF CONTROLLER (RELAY / TWO STATE / BANG-BANG)

mechanical relay

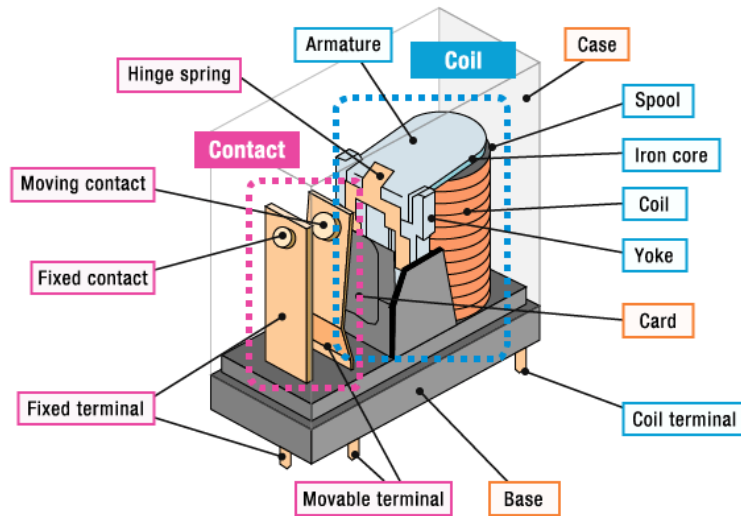

Source: <https://www.components.omron.com/relay-basics/basic>

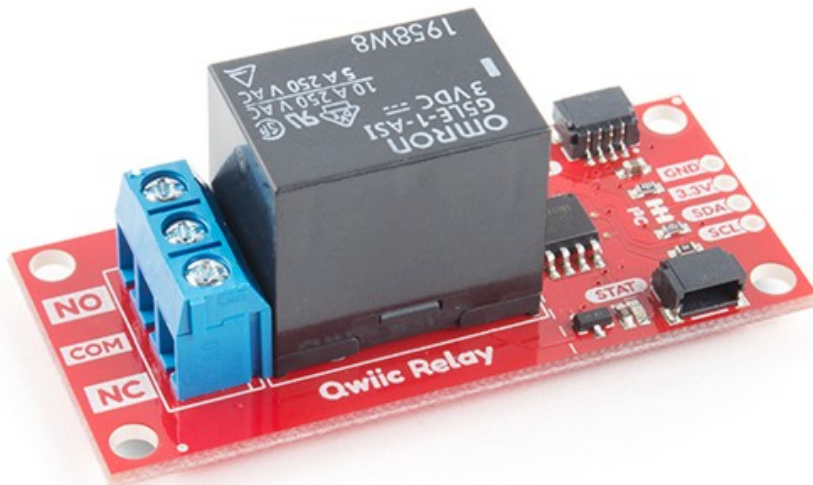

Source: <https://www.sparkfun.com/products/15093>

electronic relay  
(optoisolators, MOSFETs)

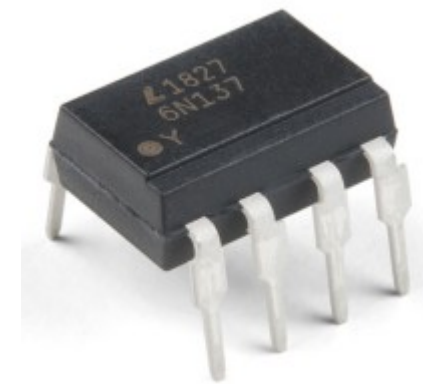

source: <https://www.sparkfun.com/products/15105>

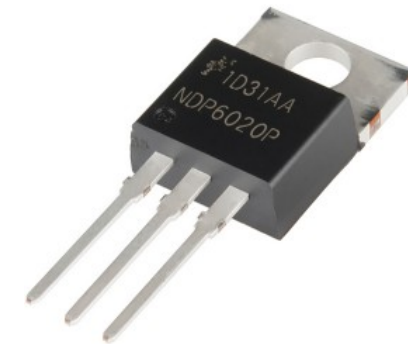

source: <https://www.sparkfun.com/products/12901>

# THREE STATE CONTROLLER

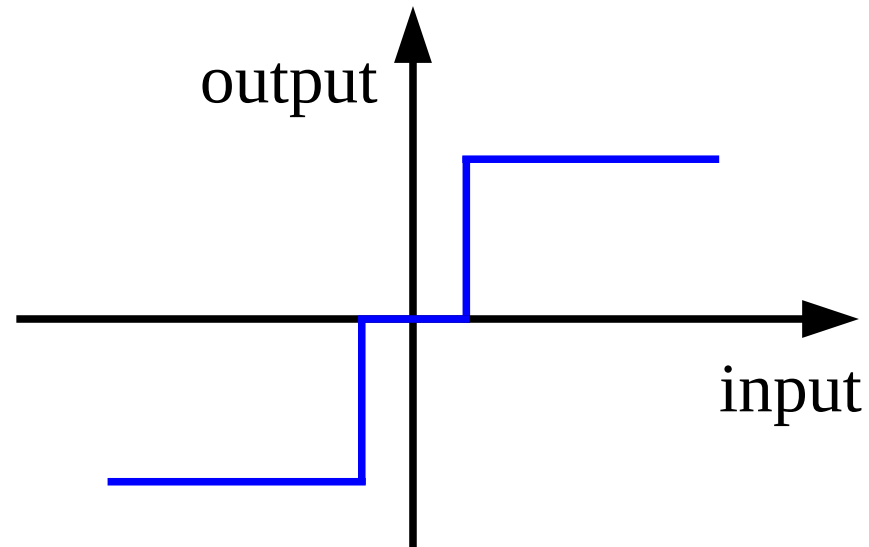

# Proportional (P) CONTROLLER

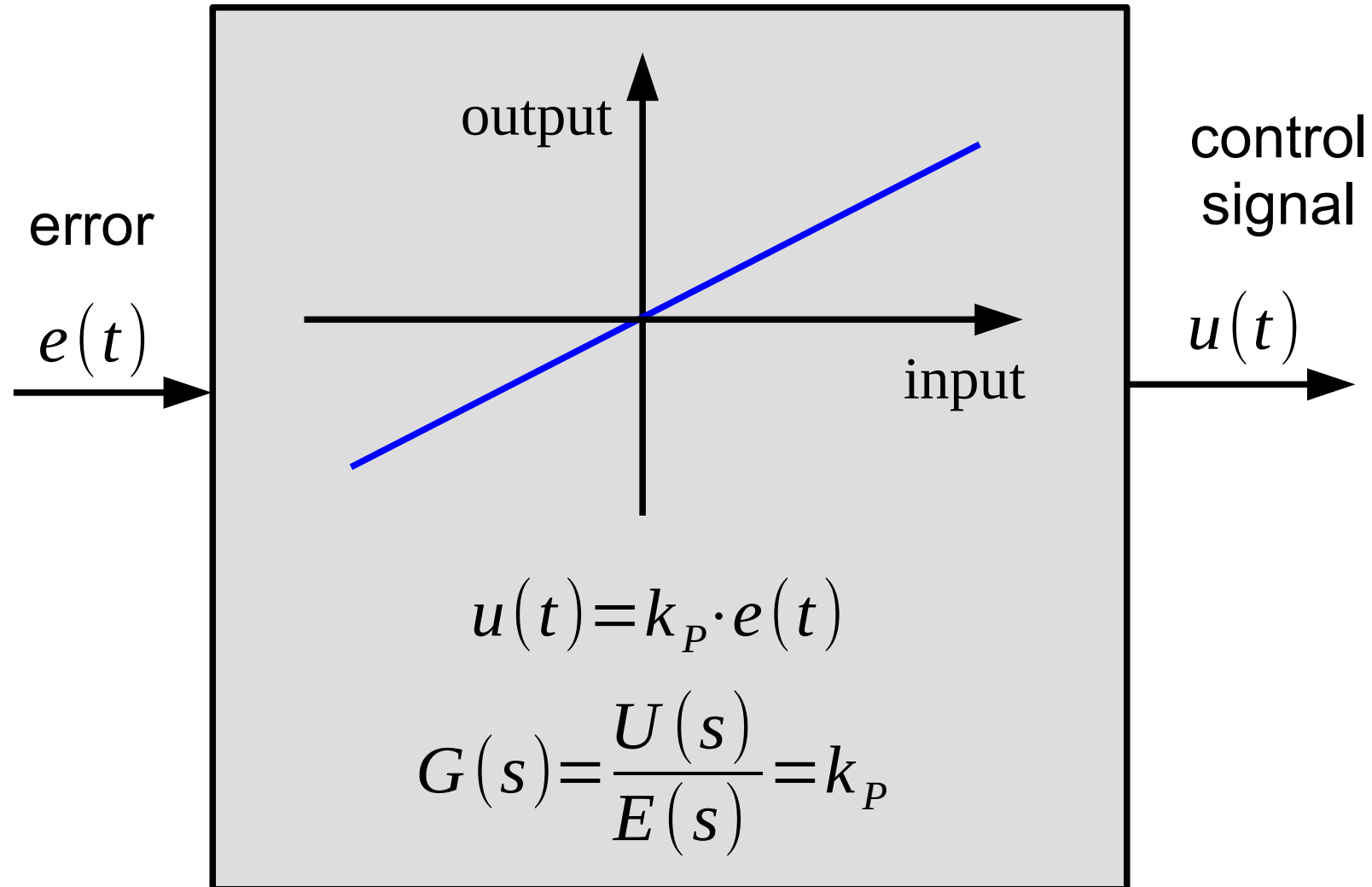

# NONLINEARITIES

## Symmetric hard limiting saturation

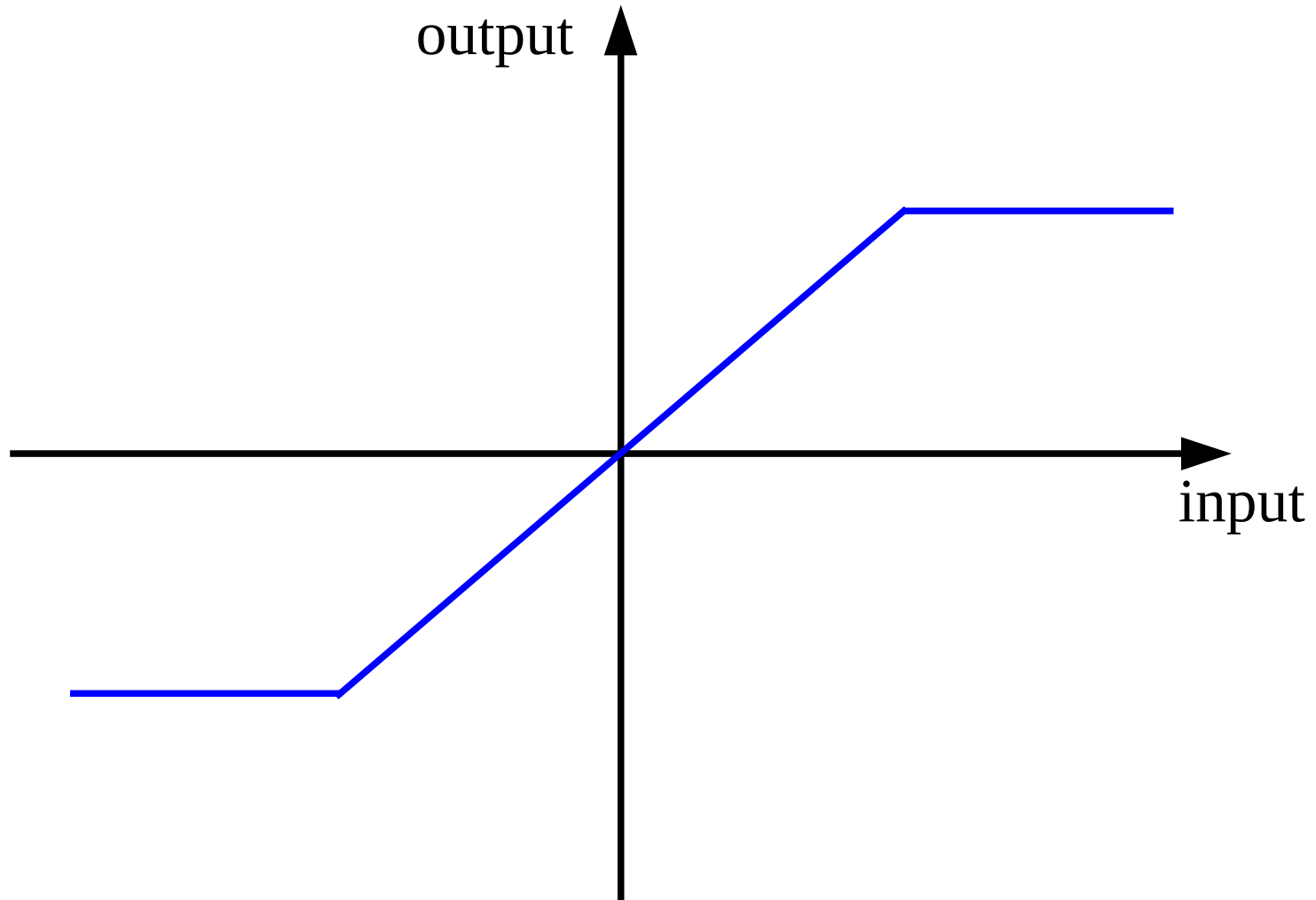



# NONLINEARITIES

## Dead zone

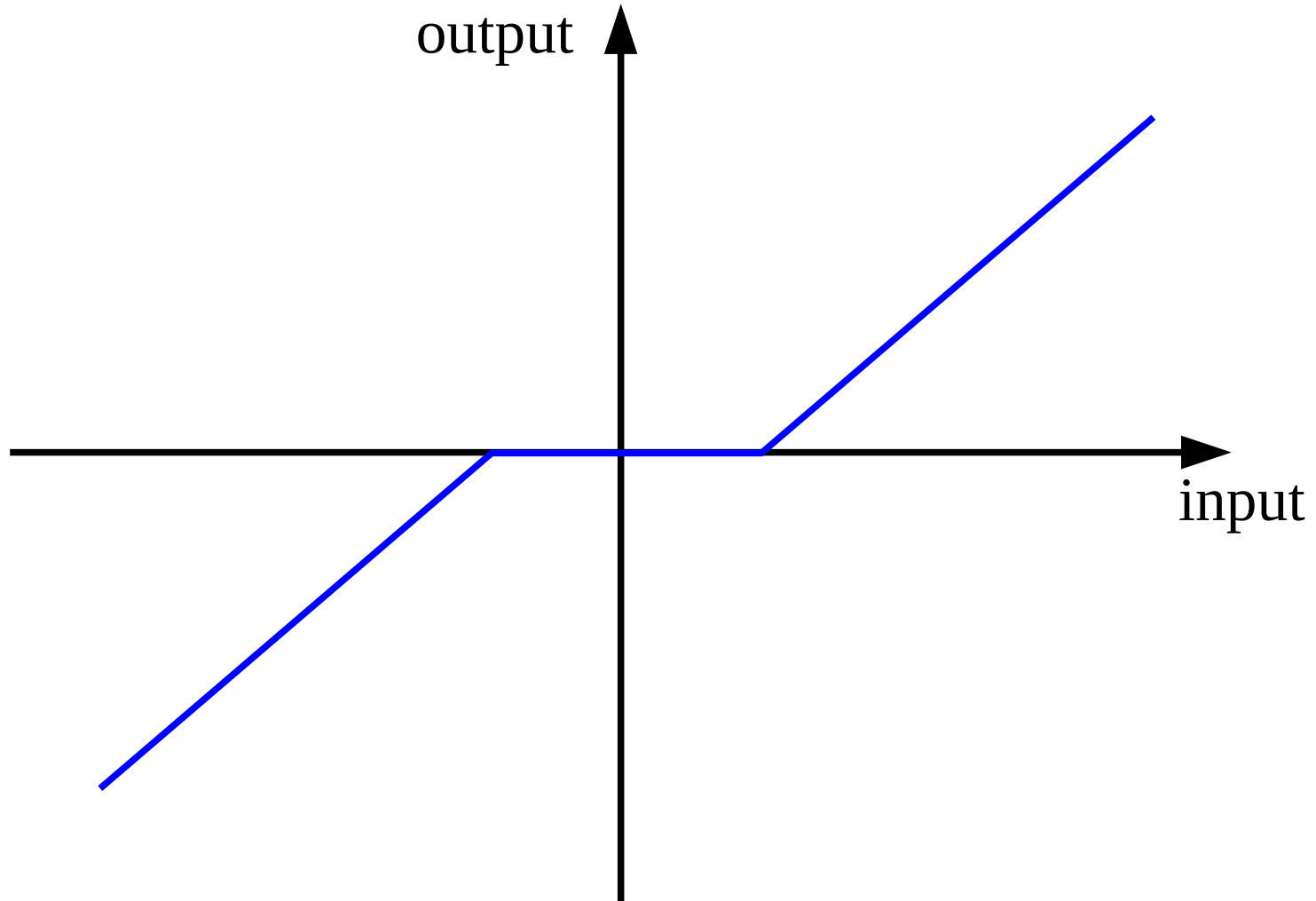

# Speed control (cruise control, autocruise, tempomat)

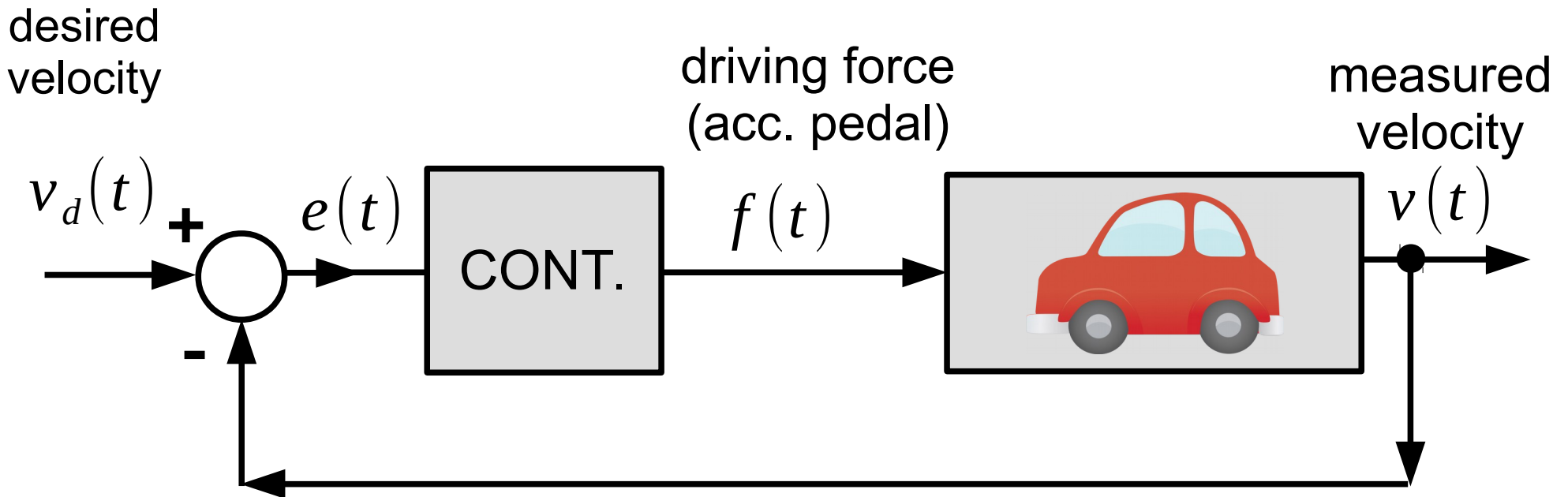

# Speed control (adaptive cruise control)

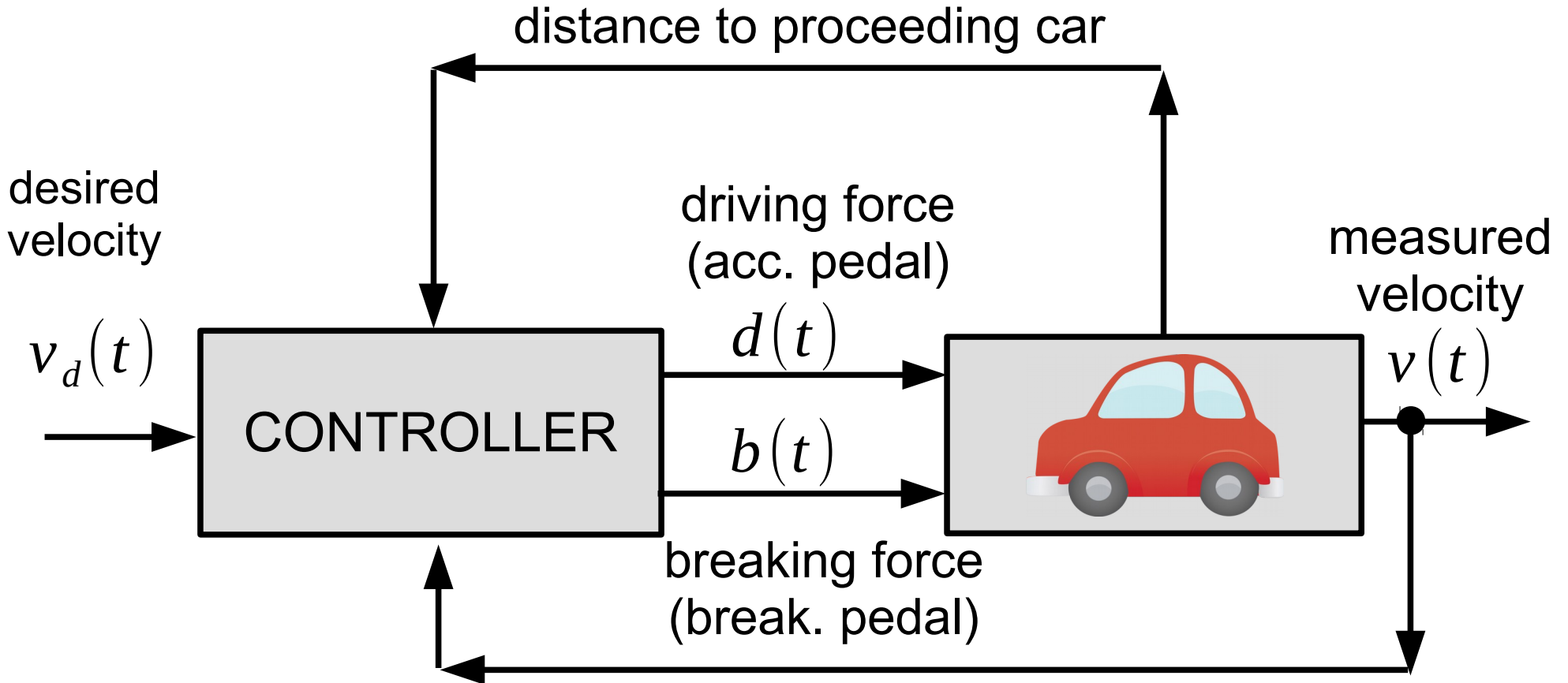

# Engine's temperature control

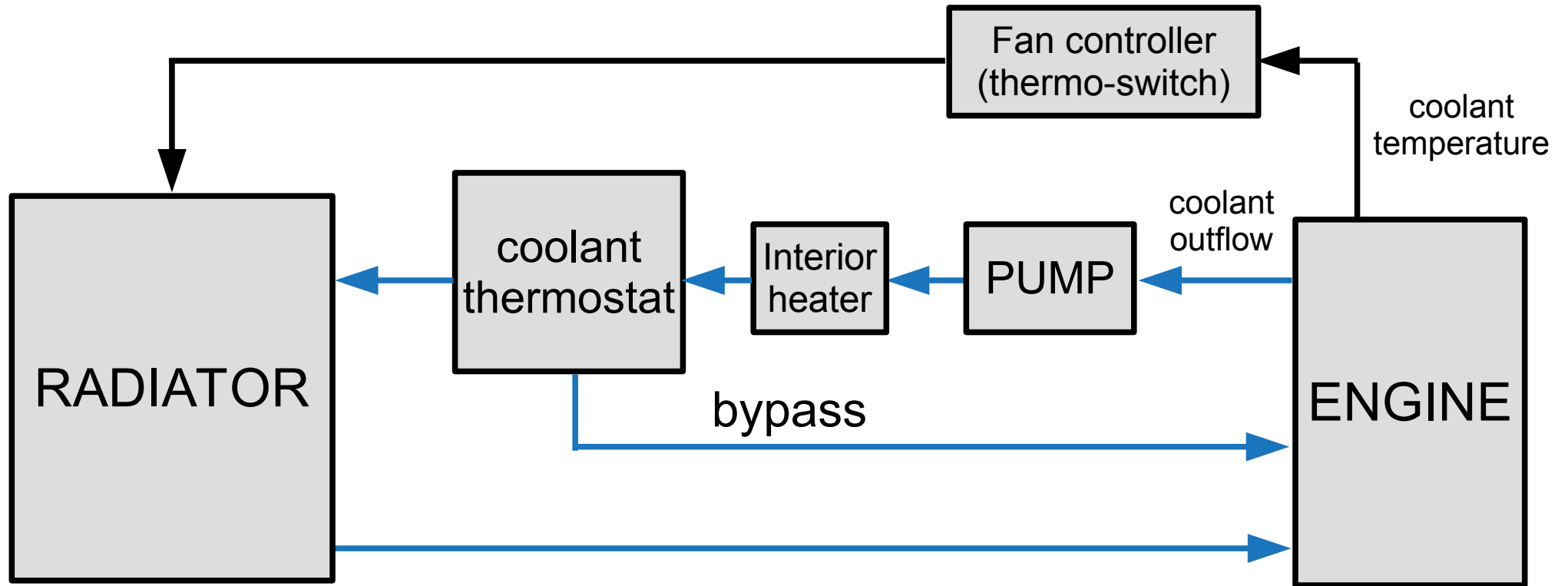

# EXAMPLE 1

## Speed control (cruise control, autocruise, tempomat)

Car on a flat surface

$m$  – mass,

$f(t)$  – driving force,

$d(t)=c*v(t)$  – air resistance,

$v(t)$  – velocity

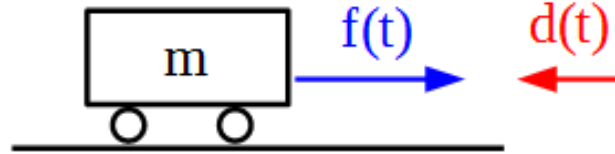

$$m \frac{dv(t)}{dt} = f(t) - d(t)$$

$$H(s) = \frac{V(s)}{F(s)} = \frac{1}{ms + c}$$

# EXAMPLE 1

## Speed control (cruise control, autocruise, tempomat)

Car on a flat surface

$m$  – mass,

$f(t)$  – driving force,

$d(t)=c*v(t)$  – air resistance,

$v(t)$  – velocity

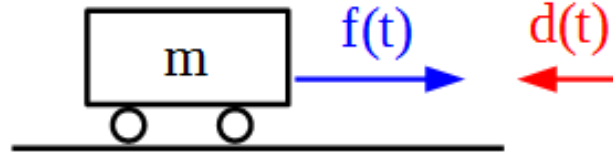

$$m \frac{dv(t)}{dt} = f(t) - d(t)$$

$$H(s) = \frac{V(s)}{F(s)} = \frac{1}{ms + c}$$

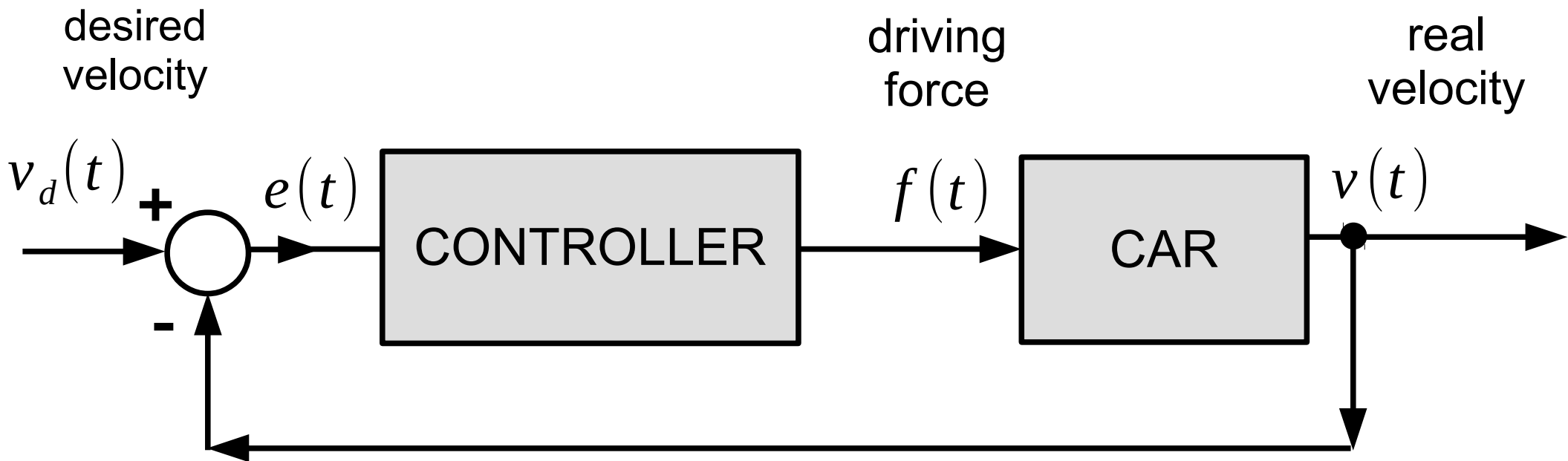

# EXAMPLE 1

Speed control (cruise control, autocruise, tempomat)

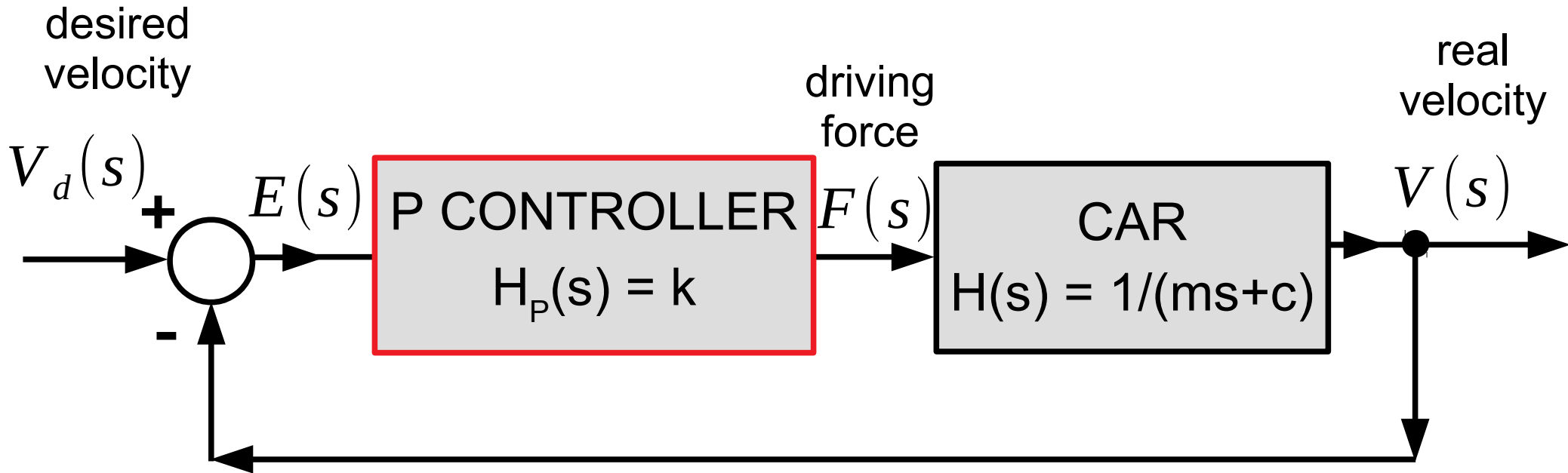

# EXAMPLE 1

Speed control (cruise control, autocruise, tempomat)

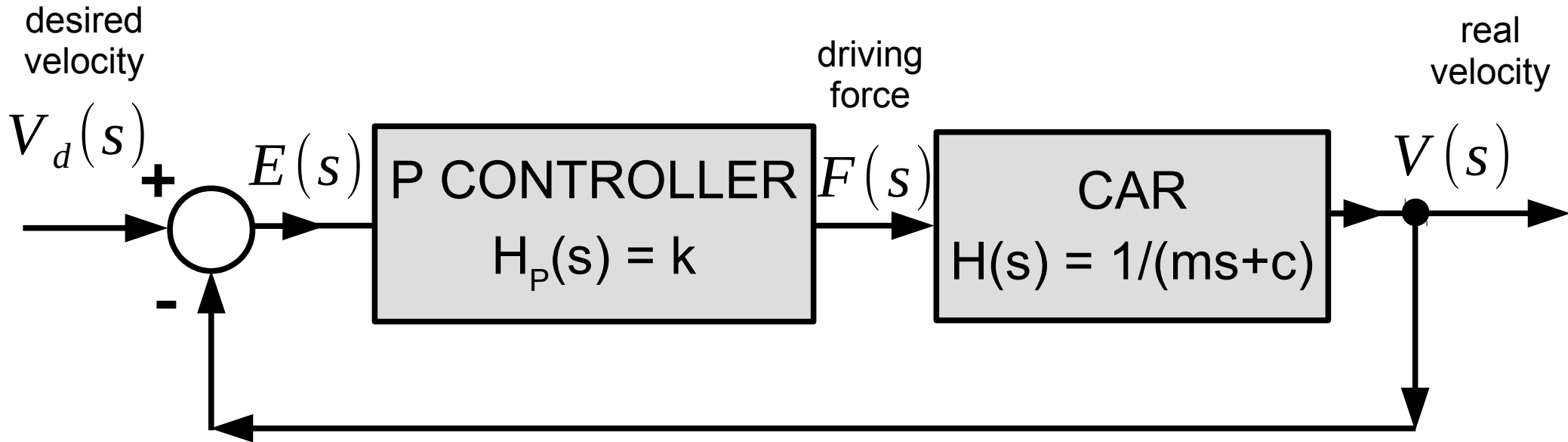

$$H_R(s) = \frac{H_P(s)H(s)}{1 + H_P(s)H(s)}$$



# EXAMPLE 1

Speed control (cruise control, autocruise, tempomat)

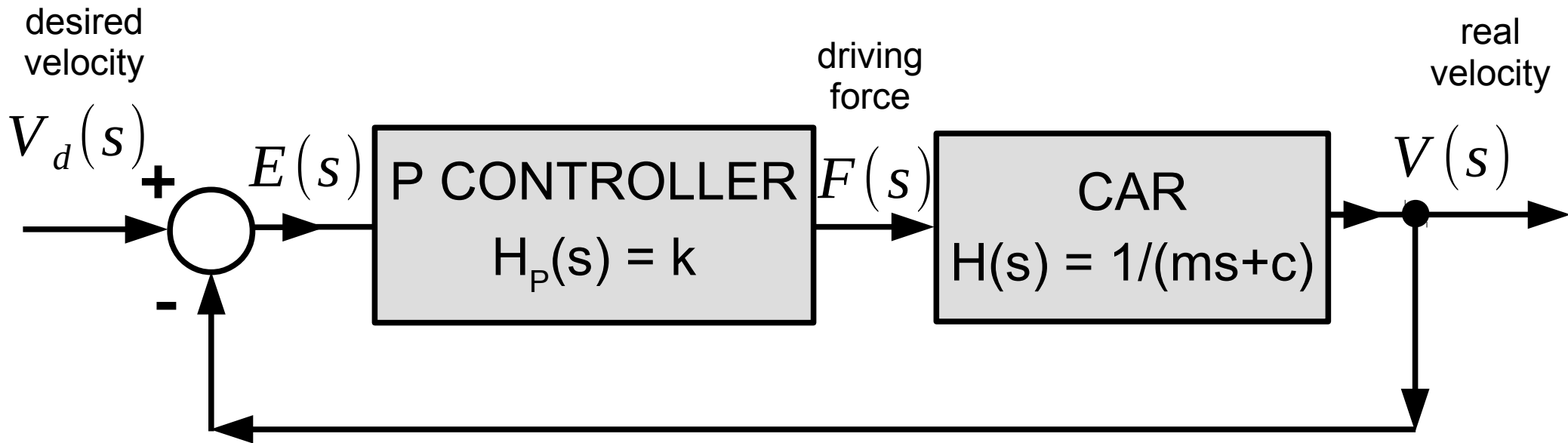

$$H_R(s) = \frac{H_P(s)H(s)}{1 + H_P(s)H(s)}$$

$$H_R(s) = \frac{k}{ms+c+k}$$

# EXAMPLE 1

Speed control (cruise control, autocruise, tempomat)

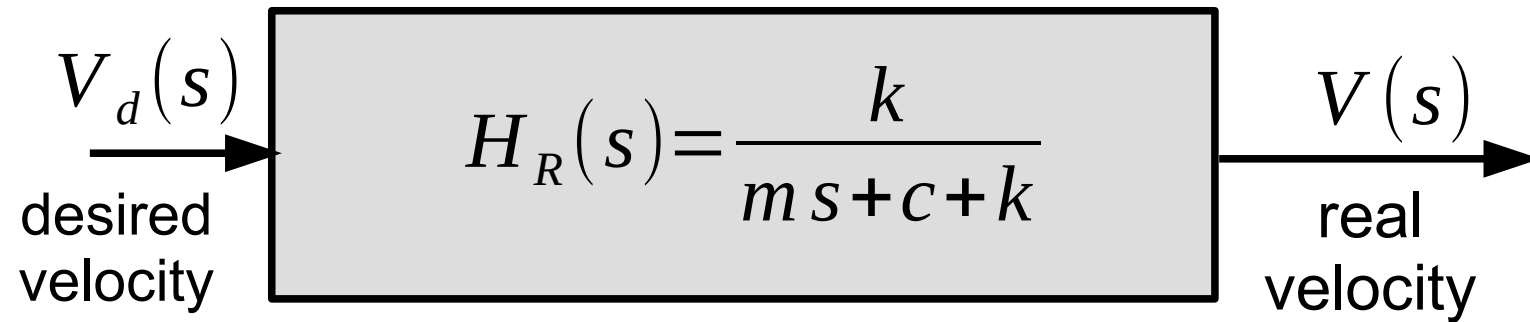

Input function:  $v_d(t) = v_0 \mathbf{1}(t)$

# EXAMPLE 1

Speed control (cruise control, autocruise, tempomat)

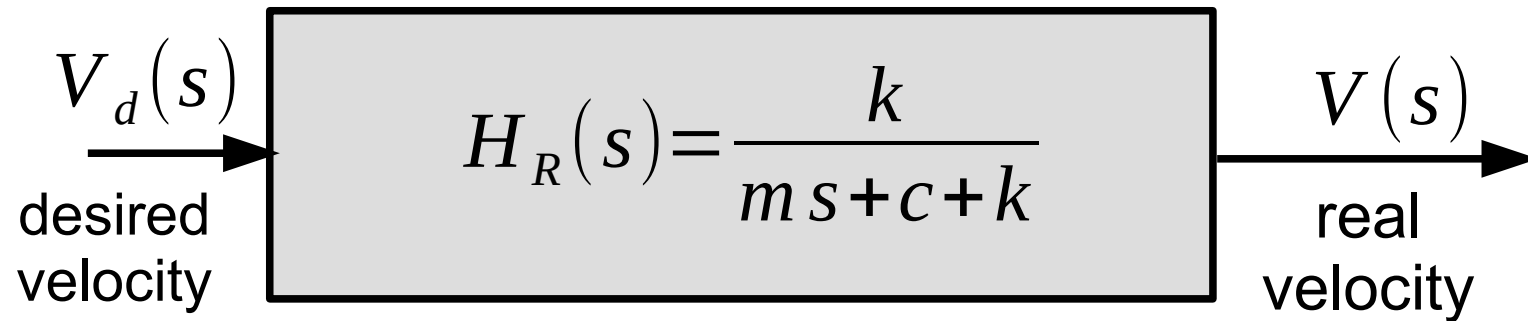

Input function:  $v_d(t) = v_0 \mathbf{1}(t)$       Laplace of input:  $V_d(s) = v_0 \frac{1}{s}$

Laplace of output:

$$V(s) = V_d(s) H_R(s) = \frac{v_0 k}{s(ms + c + k)} = \frac{v_0 k}{c + k} \frac{\frac{c + k}{m}}{s \left( s + \frac{c + k}{m} \right)}$$

# EXAMPLE 1

Speed control (cruise control, autocruise, tempomat)

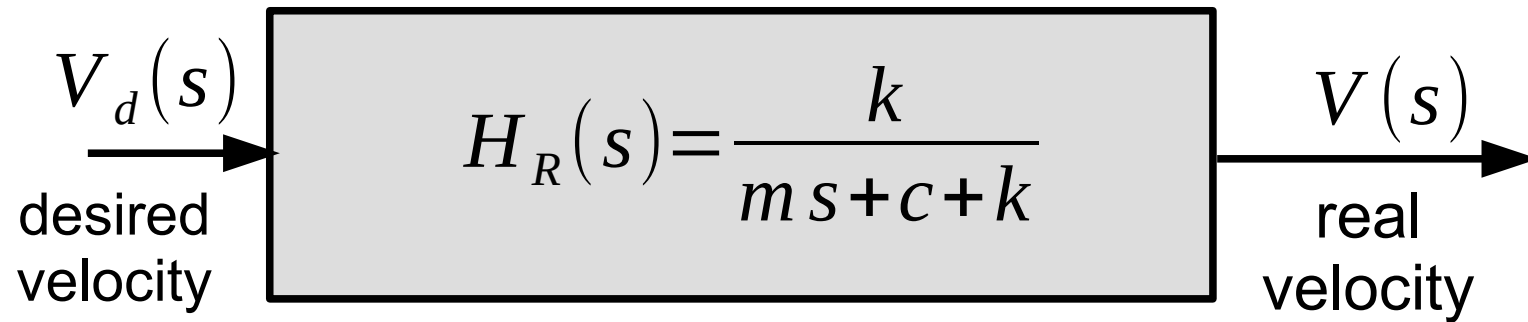

Input function:  $v_d(t) = v_0 \mathbf{1}(t)$       Laplace of input:  $V_d(s) = v_0 \frac{1}{s}$

Laplace of output:

$$V(s) = V_d(s) H_R(s) = \frac{v_0 k}{s(ms + c + k)} = \frac{v_0 k}{c + k} \frac{\frac{c + k}{m}}{s \left( s + \frac{c + k}{m} \right)}$$

Output:

$$v(t) = \frac{v_0 k}{c + k} \left( 1 - \exp \left( - \frac{c + k}{m} t \right) \right)$$

# EXAMPLE 1

Speed control (cruise control, autocruise, tempomat)

$$v(t) = v_0 \frac{k}{c+k} \left( 1 - \exp\left(-\frac{c+k}{m} t\right) \right)$$

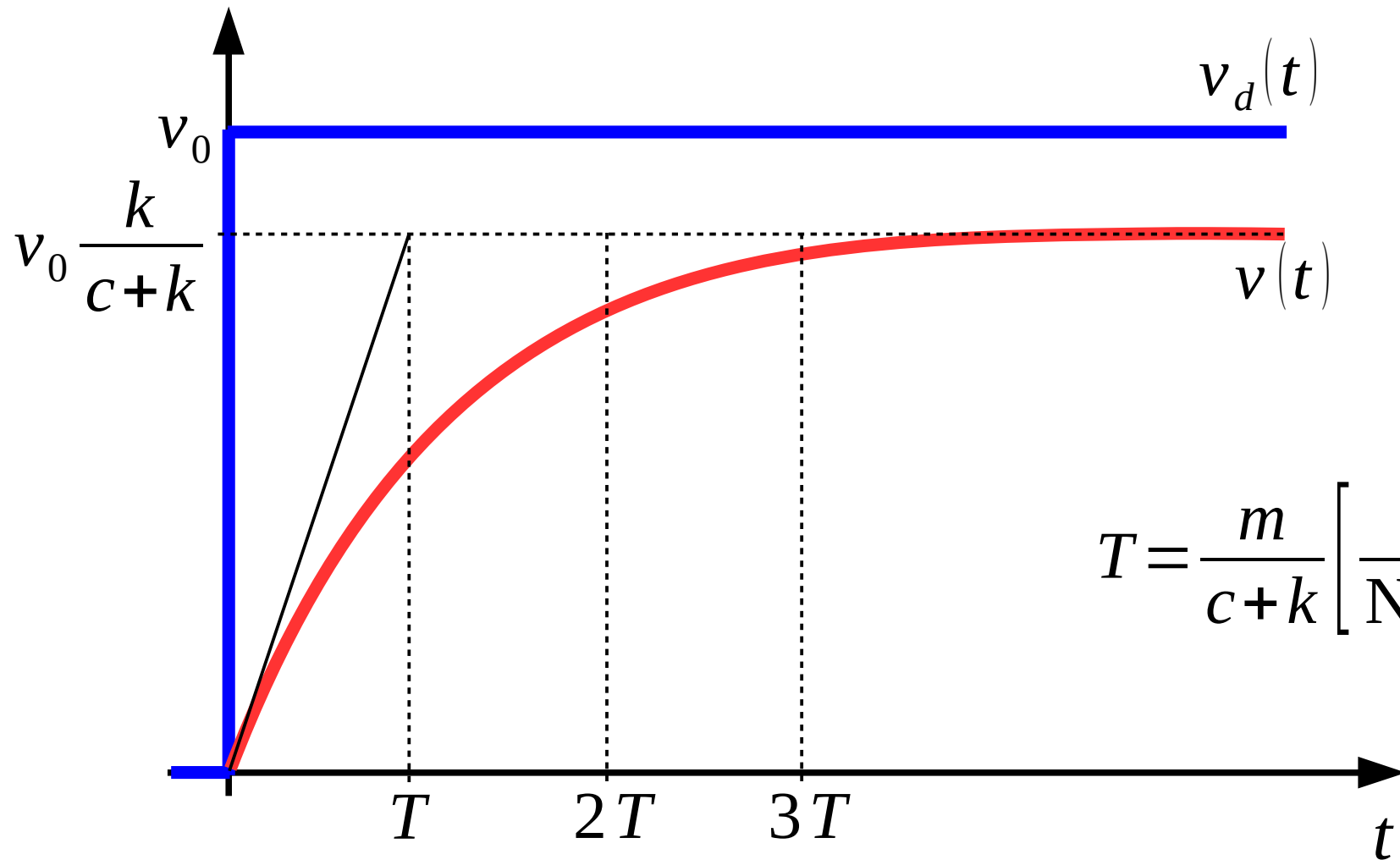

$$T = \frac{m}{c+k} \left[ \frac{\text{kg}}{\text{Ns/m}} = \text{s} \right]$$

# EXAMPLE 1

Speed control (cruise control, autocruise, tempomat)

$$v(t) = v_0 \frac{k}{c+k} \left( 1 - \exp\left(-\frac{c+k}{m} t\right) \right)$$

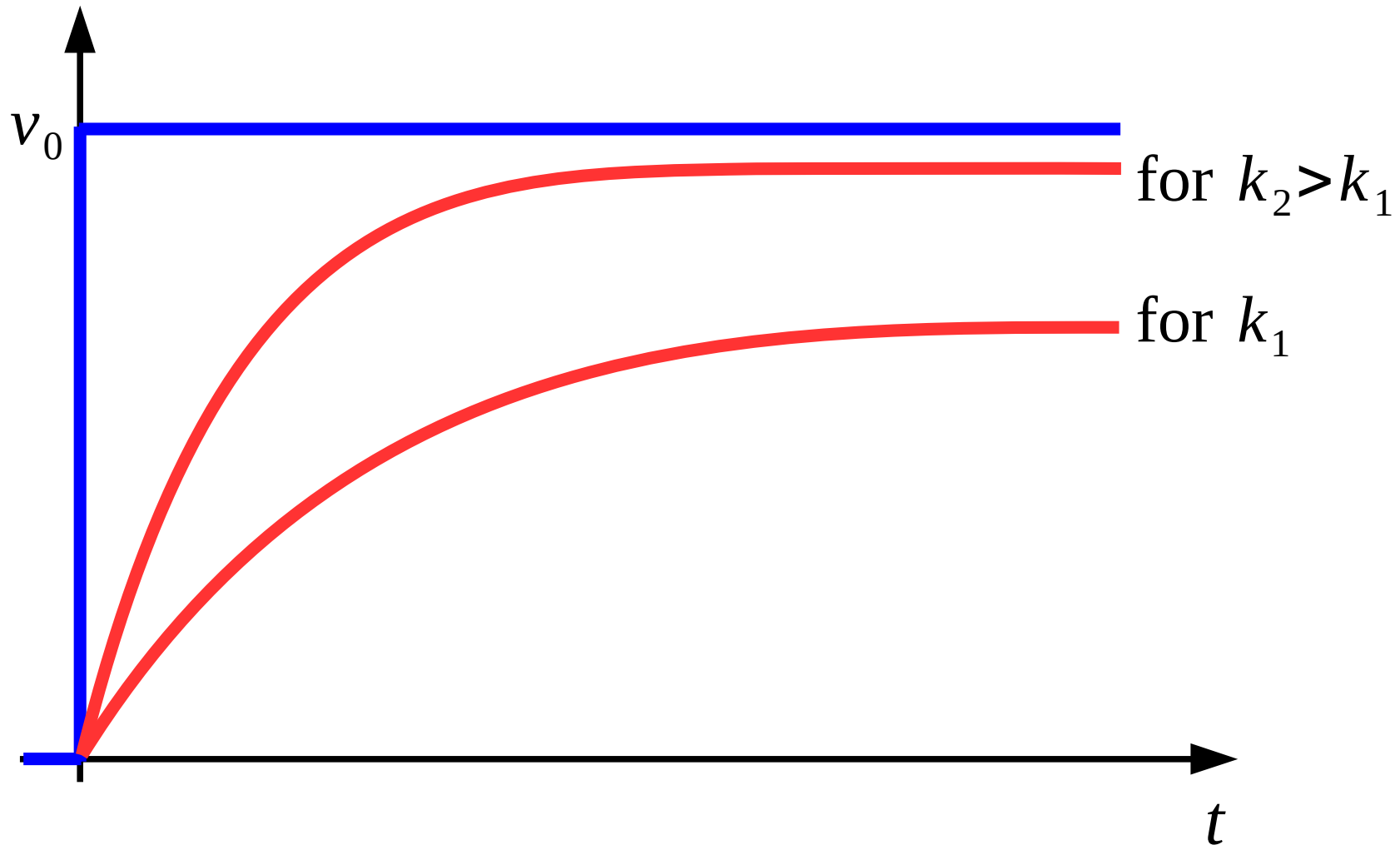

# EXAMPLE 1

Speed control (cruise control, autocruise, tempomat)

$$v(t) = v_0 \frac{k}{c+k} \left( 1 - \exp\left(-\frac{c+k}{m} t\right) \right)$$

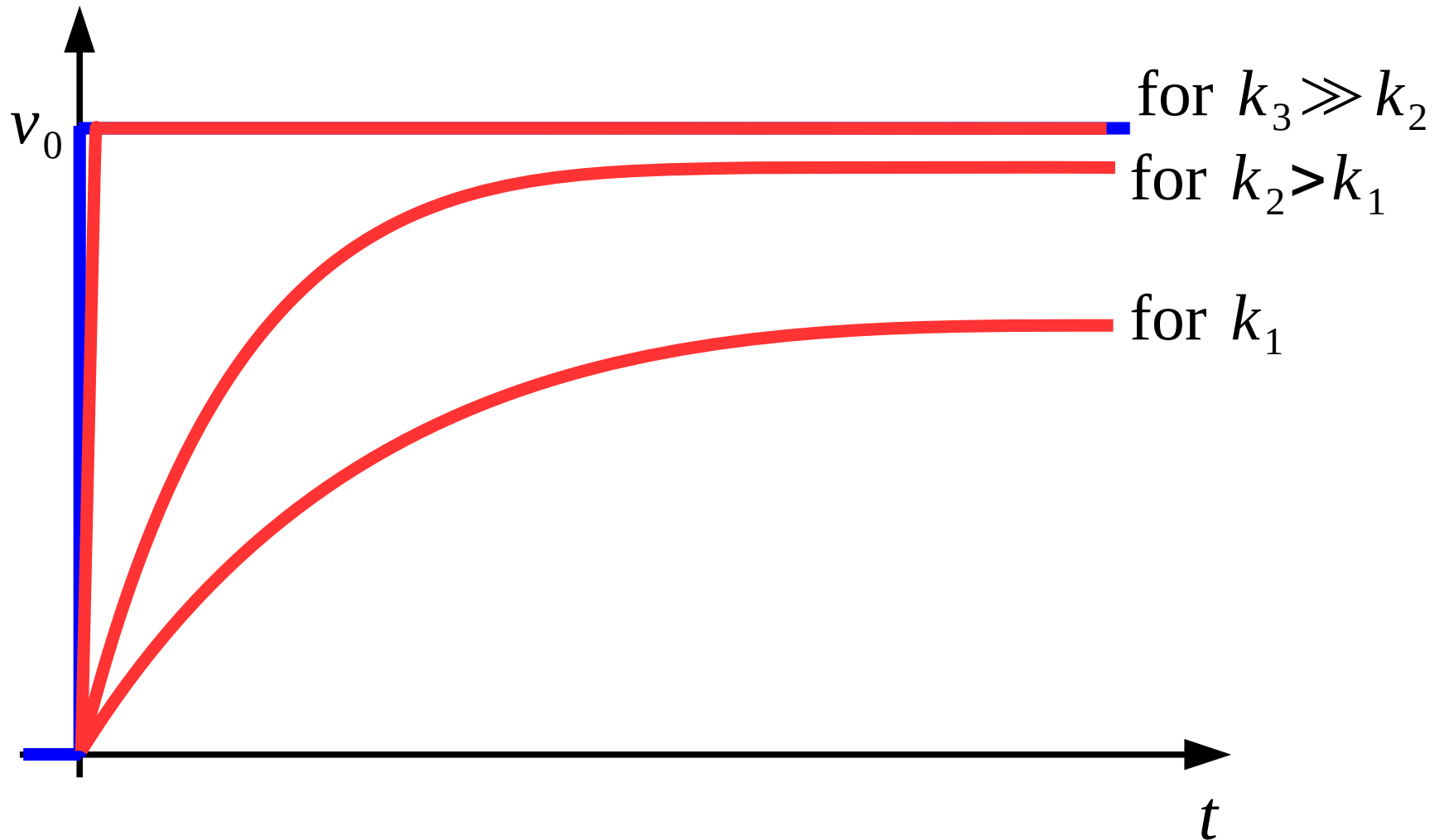

# EXAMPLE 1

Speed control (cruise control, autocruise, tempomat)

$$v(t) = v_0 \frac{k}{c+k} \left( 1 - \exp\left(-\frac{c+k}{m} t\right) \right)$$

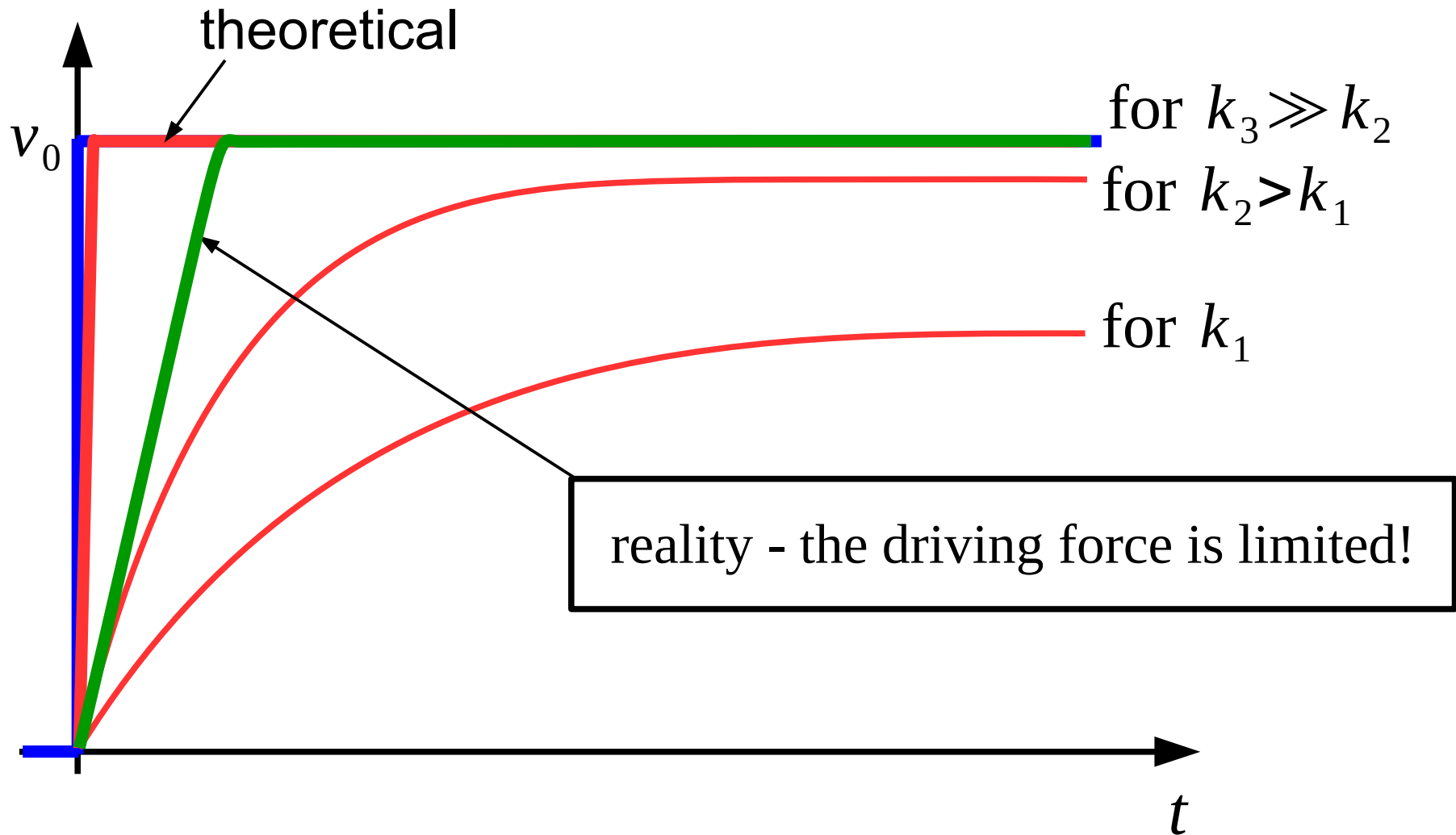



# EXAMPLE 1

Speed control (cruise control, autocruise, tempomat)  
driving force

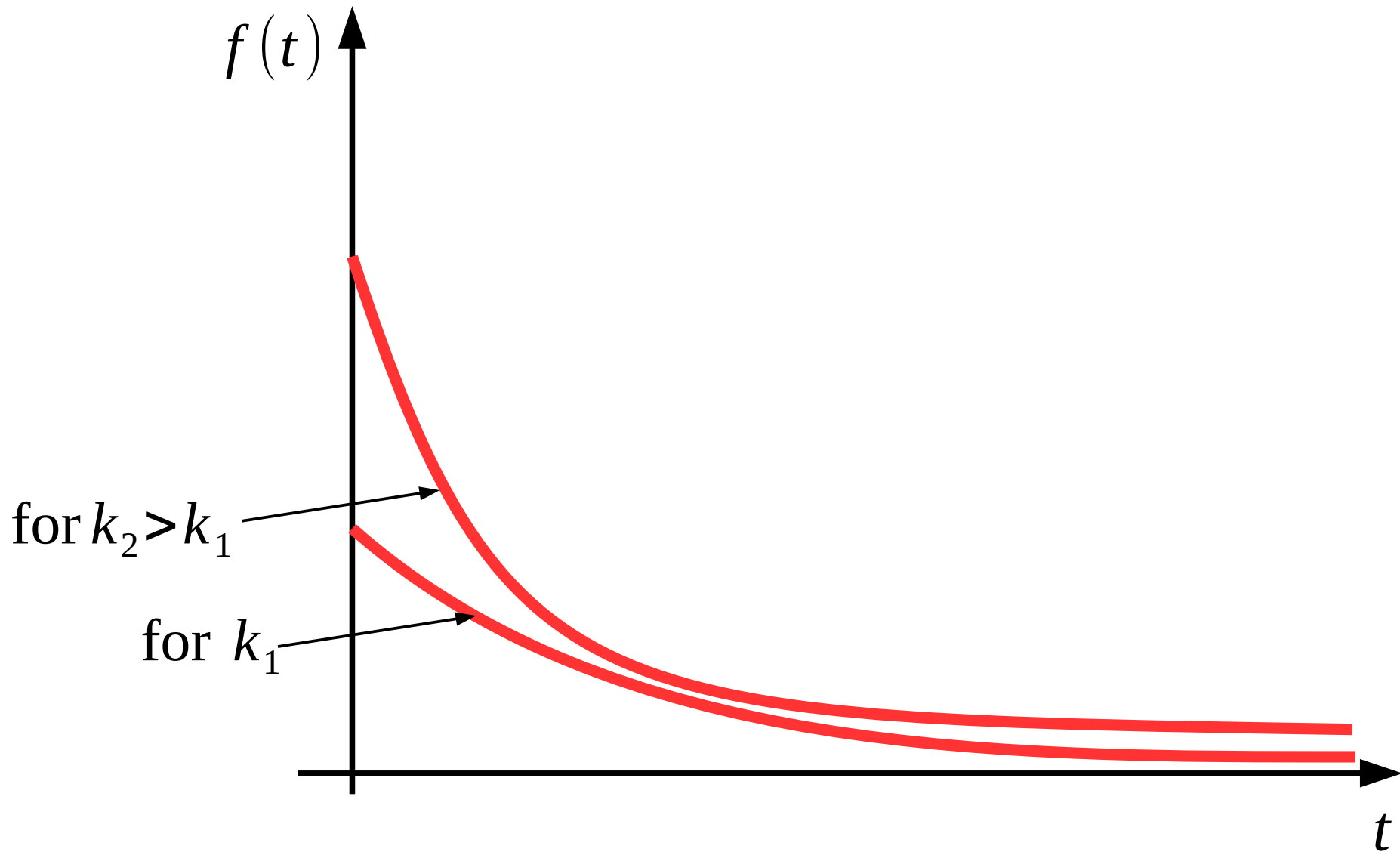

# EXAMPLE 1

Speed control (cruise control, autocruise, tempomat)  
driving force

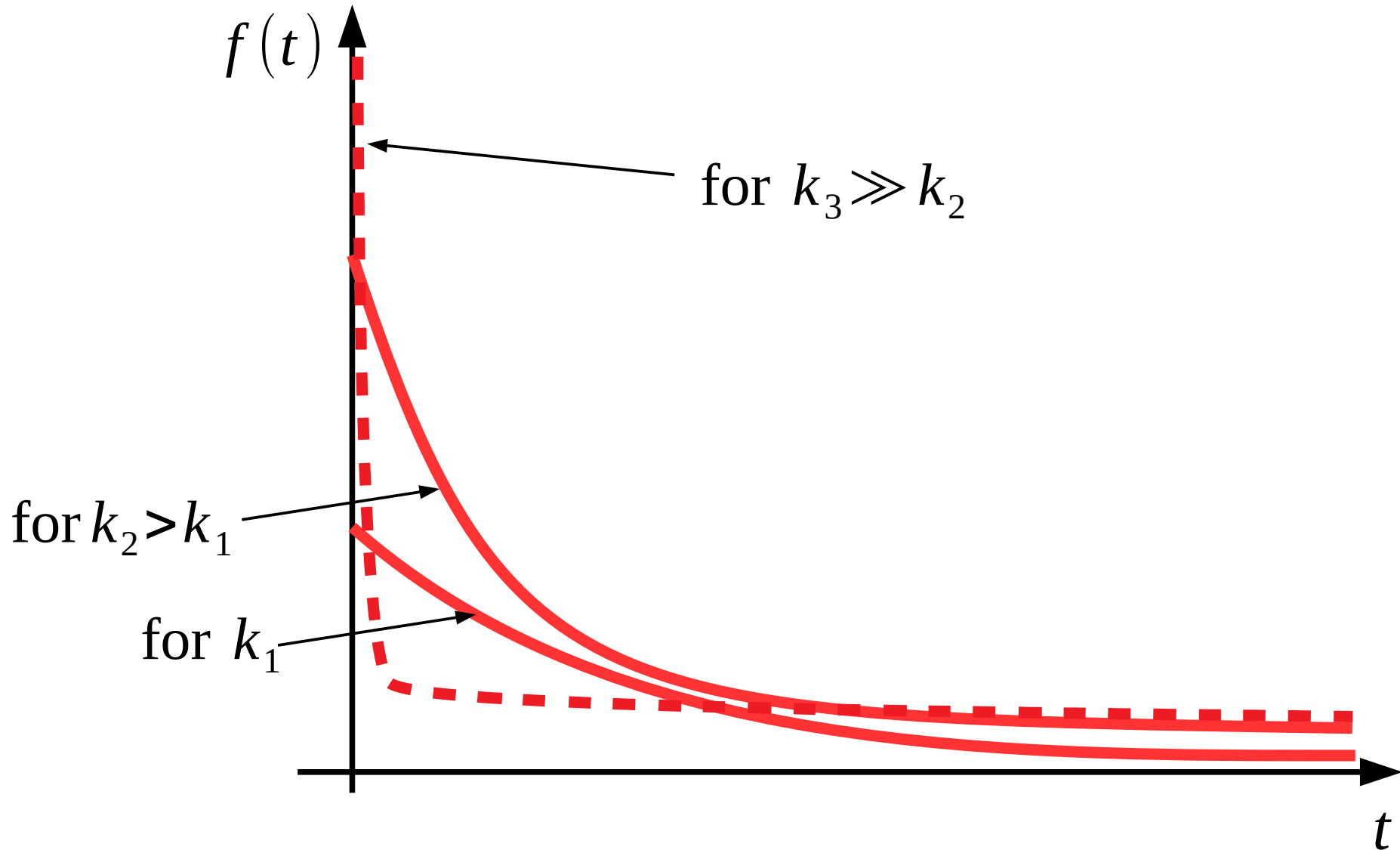

# EXAMPLE 1

Speed control (cruise control, autocruise, tempomat)  
driving force

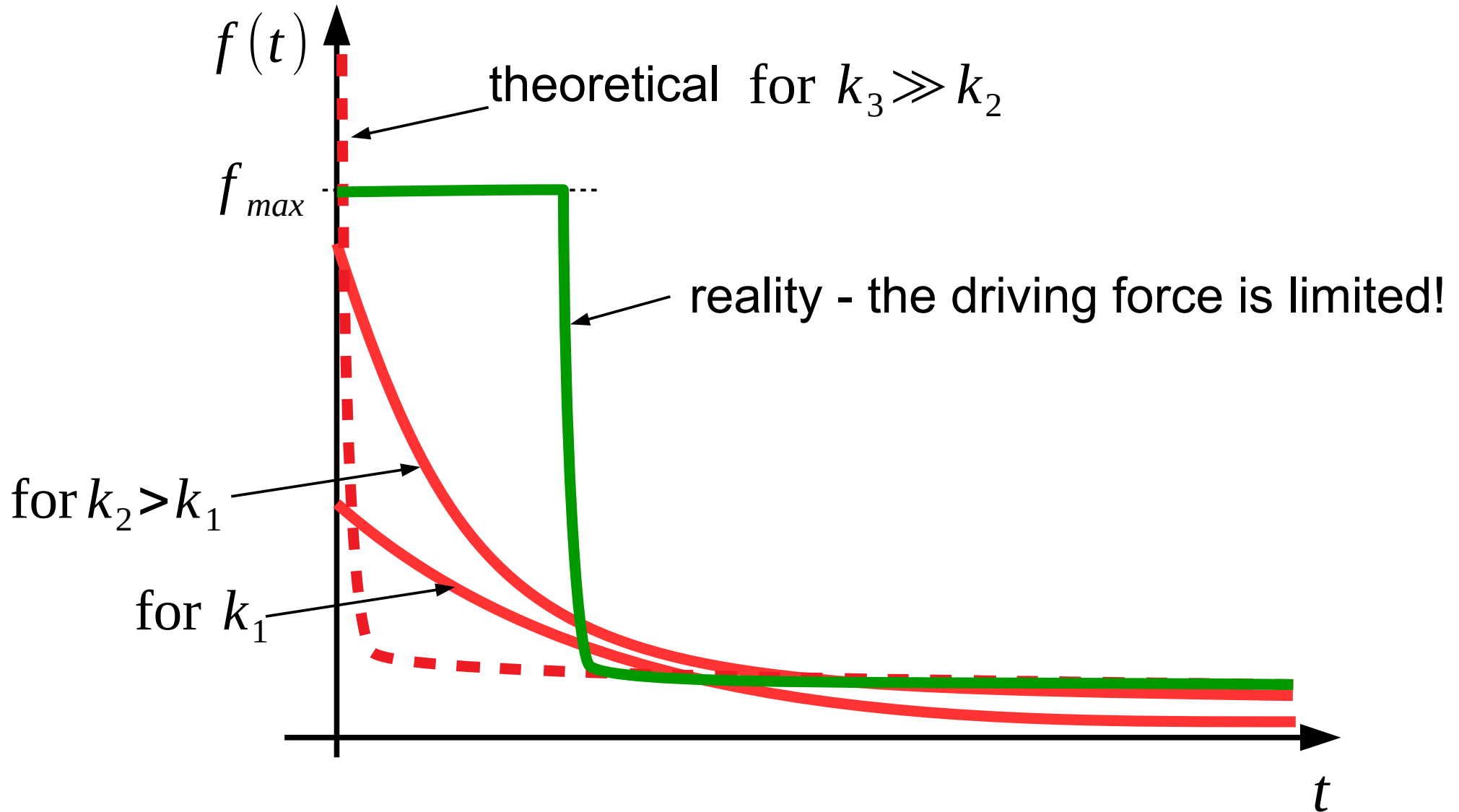

# EXAMPLE 1

Speed control (cruise control, autocruise, tempomat)

$$v(t) = v_0 \frac{k}{c+k} \left( 1 - \exp\left(-\frac{c+k}{m} t\right) \right)$$

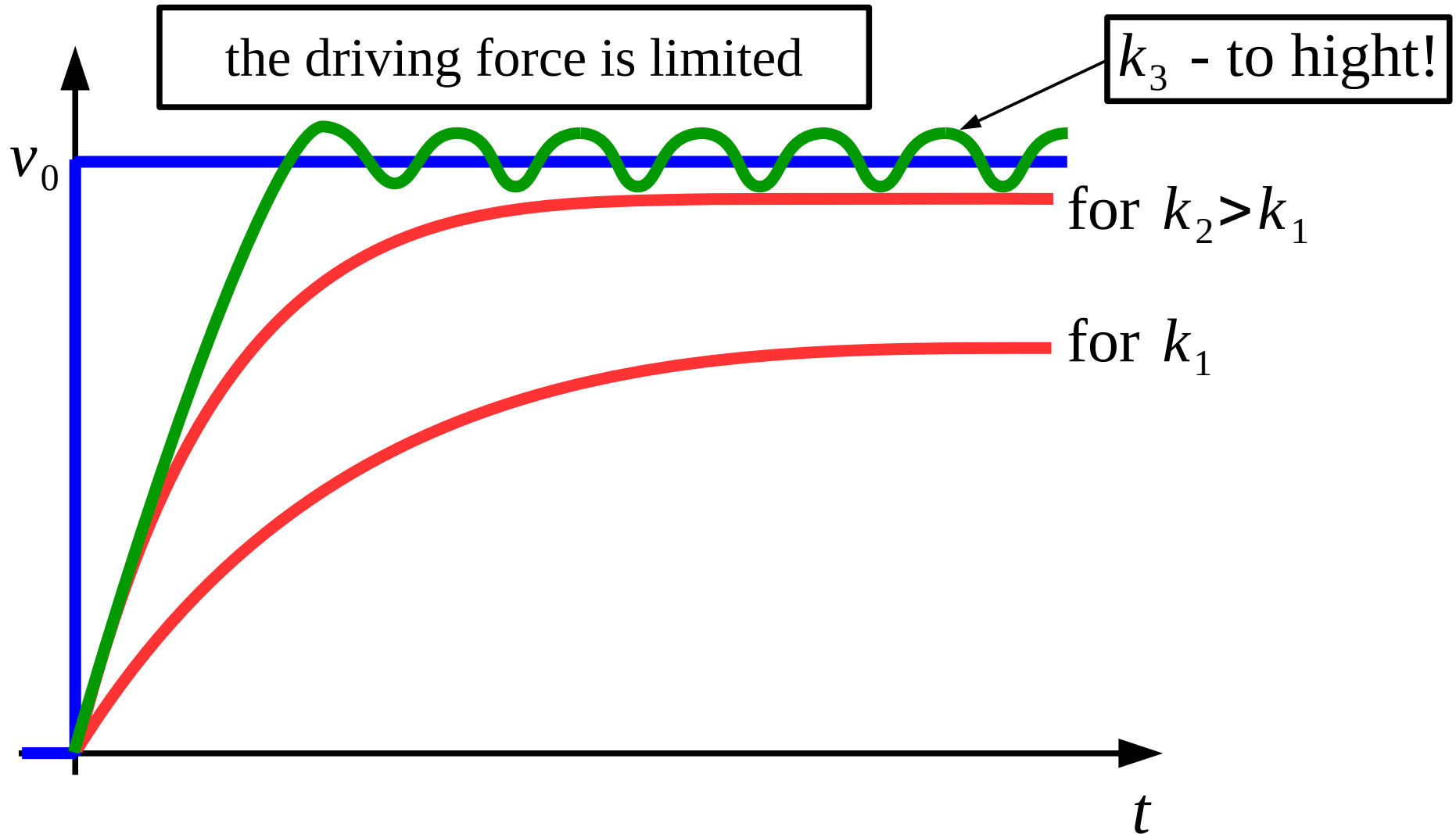

# NOTE

Control signal limitation

=

System is nonlinear

=

Linear model (transfer function) is not  
valid in all situations

# EXAMPLE 1

Speed control (cruise control, autocruise, tempomat)

$$H_R(s) = \frac{k}{ms + c + k}, \quad H(j\omega) = \frac{k}{mj\omega + c + k}$$

$$P(\omega) = \frac{k(c+k)}{m^2\omega^2 + (c+k)^2}, \quad Q(\omega) = \frac{-km\omega}{m^2\omega^2 + (c+k)^2}$$

for  $k > 0$

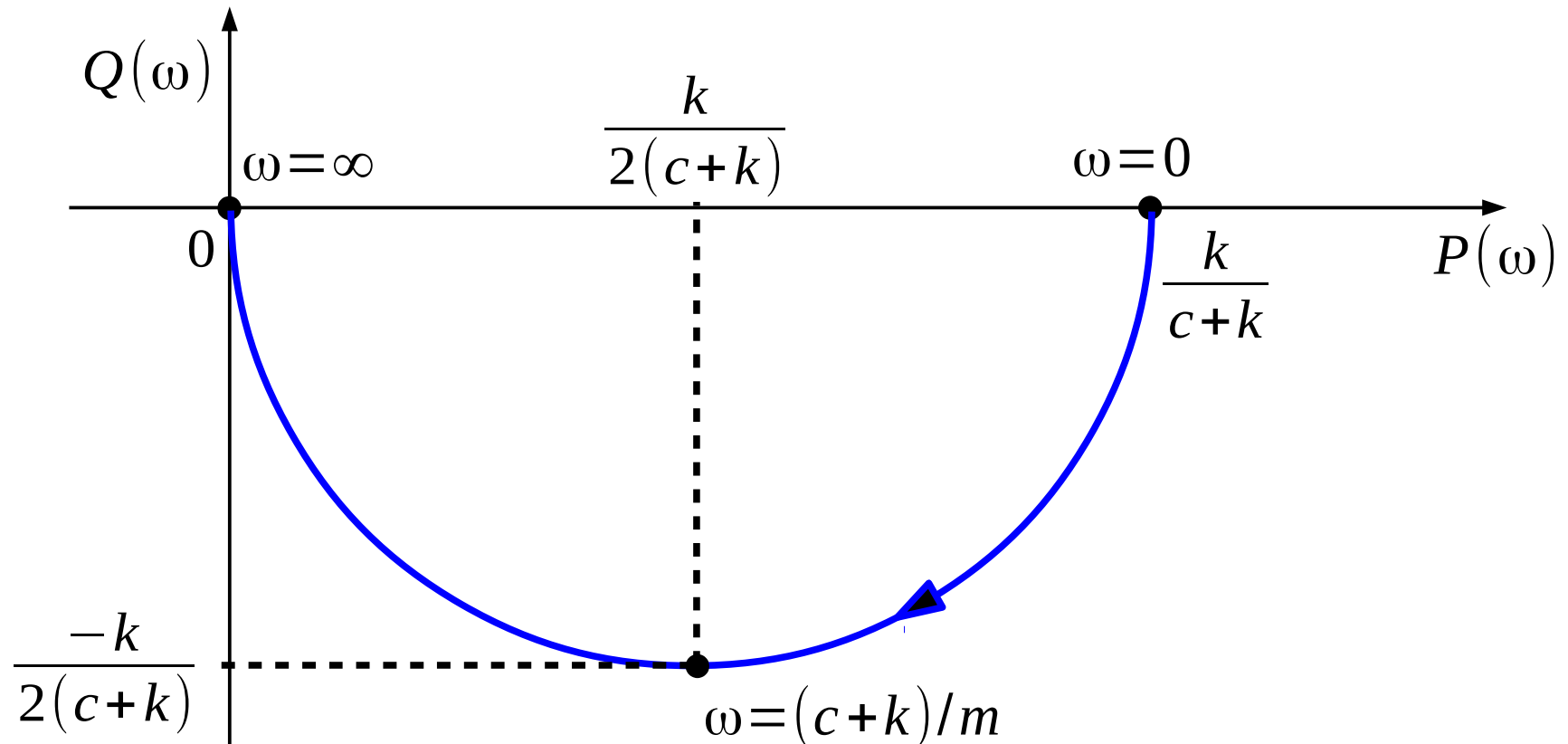

# EXAMPLE 1

Speed control (cruise control, autocruise, tempomat)

$$A(\omega) = \sqrt{P^2 + Q^2} = |k| / \sqrt{m^2 \omega^2 + c + k}$$

$$L(\omega) = 20 \log A(\omega) = 20 \log |k| - 20 \log \sqrt{m^2 \omega^2 + (c+k)^2}$$

$$\varphi(\omega) = \arctan \frac{Q}{P} = \arctan \left( -\frac{m \omega}{c+k} \right)$$

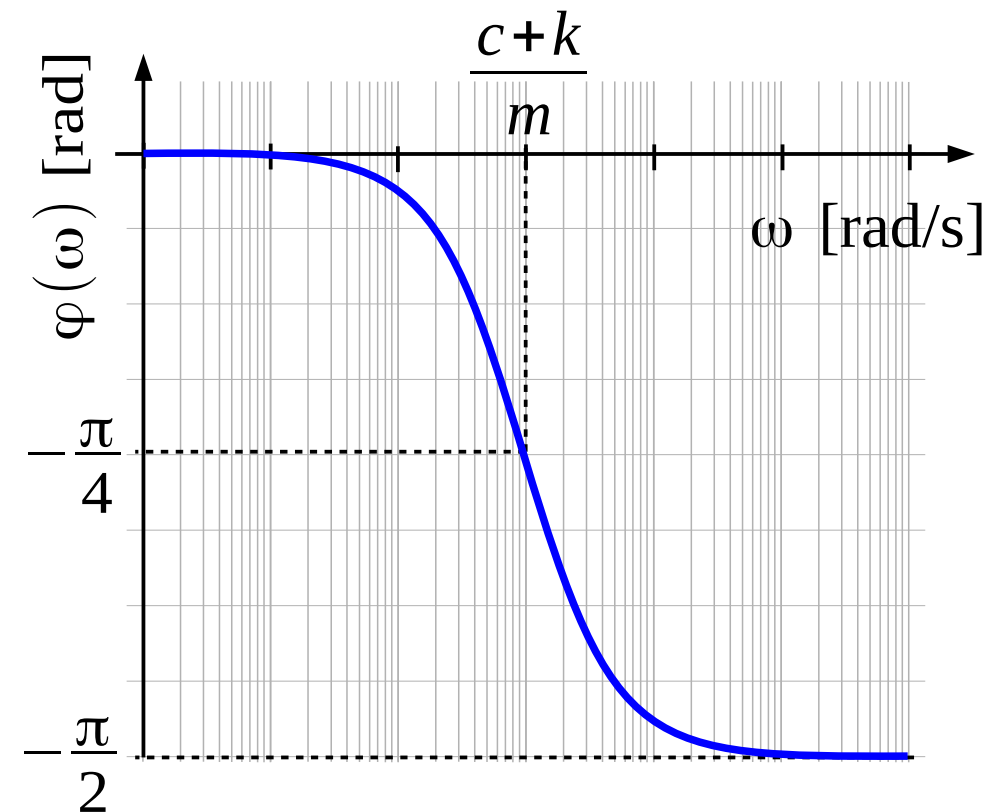
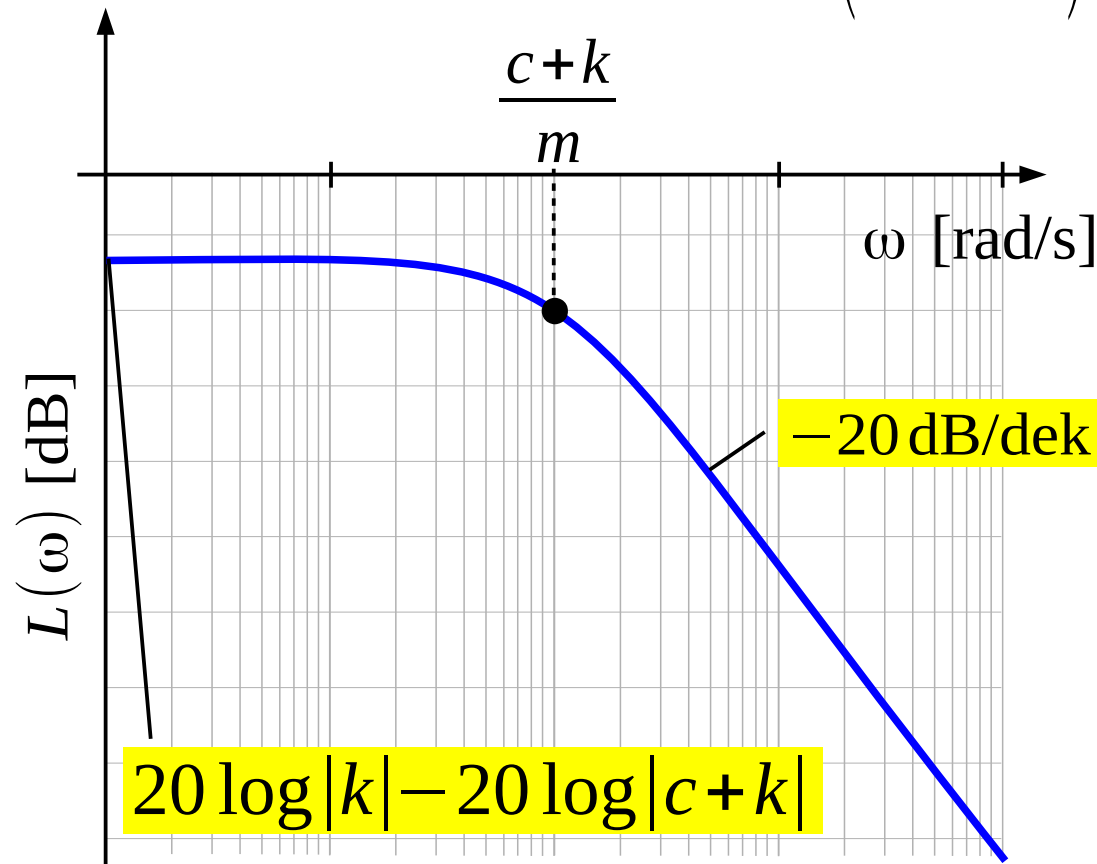

# EXAMPLE 1

Speed control (cruise control, autocruise, tempomat)

## Conclusions for “P” controller + first order system

- constant error in steady state
- P gain increasing = rise time decreasing + error decreasing
- control signal limitations = rise time limitations
- control signal limitations = nonlinear system



# EXAMPLE 2

## Water level control

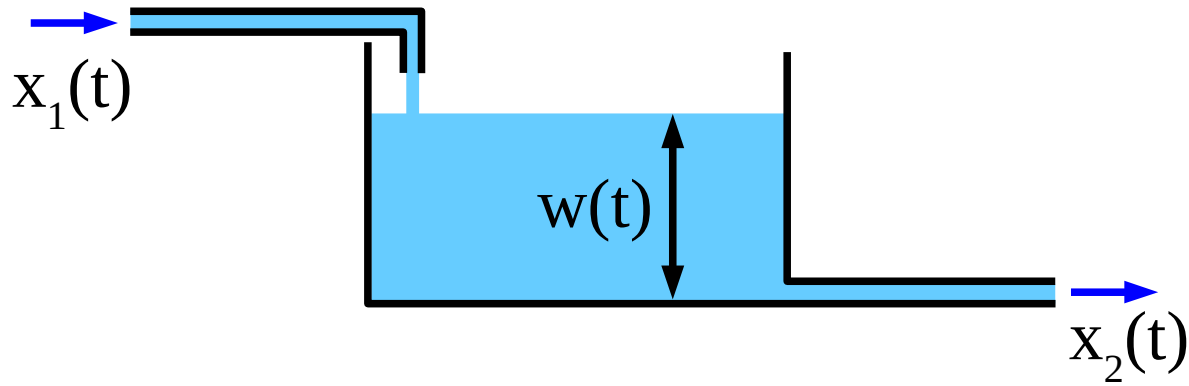

$x_1(t)$  [ $m^3/s$ ] - inflow of a liquid (controlled)

$x_2(t)$  [ $m^3/s$ ] - outflow of a liquid (not controlled)

$w(t)$  [ $m$ ] - level of a liquid in a tank

$A$  [ $m^2$ ] - constant surface area

# EXAMPLE 2

## Water level control

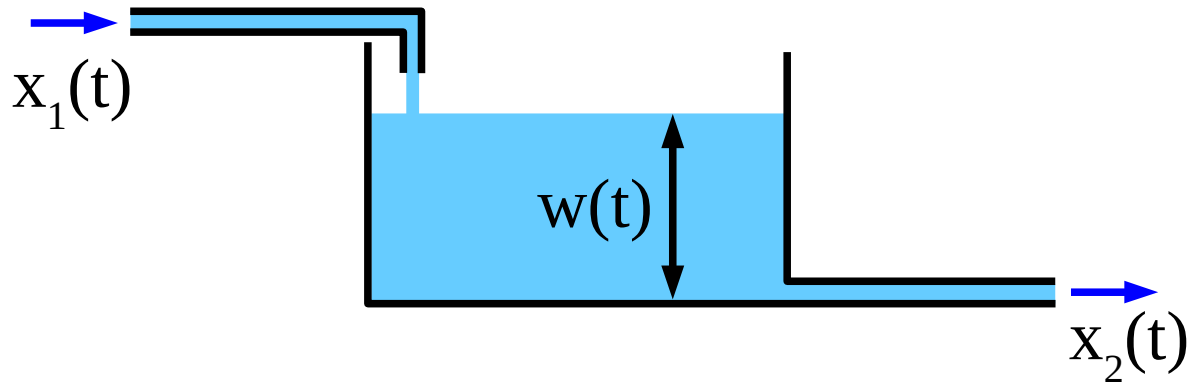

$x_1(t)$  [ $m^3/s$ ] - inflow of a liquid (controlled)

$x_2(t)$  [ $m^3/s$ ] - outflow of a liquid (not controlled)

$w(t)$  [ $m$ ] - level of a liquid in a tank

$A$  [ $m^2$ ] - constant surface area

$$\frac{dv(t)}{dt} = x_1(t) - x_2(t)$$

# EXAMPLE 2

## Water level control

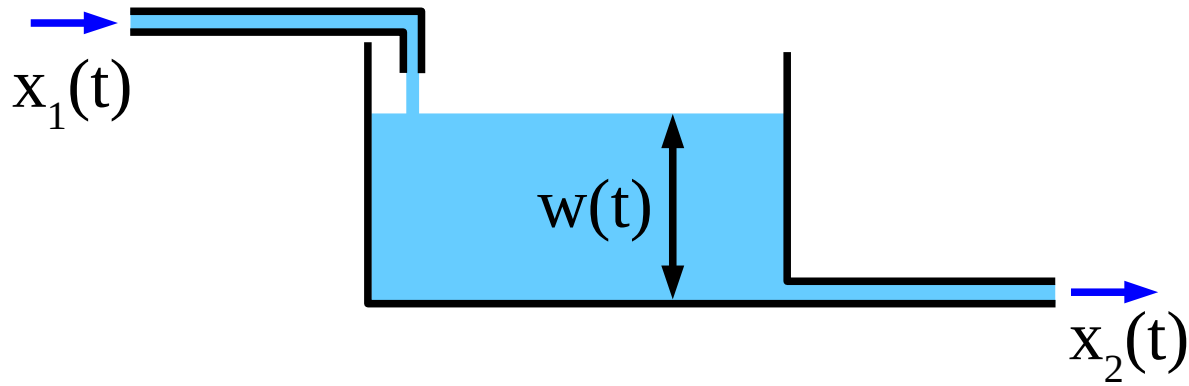

$x_1(t)$  [ $m^3/s$ ] - inflow of a liquid (controlled)

$x_2(t)$  [ $m^3/s$ ] - outflow of a liquid (not controlled)

$w(t)$  [ $m$ ] - level of a liquid in a tank

$A$  [ $m^2$ ] - constant surface area

$$\frac{dv(t)}{dt} = x_1(t) - x_2(t)$$

$$A \frac{dw(t)}{dt} = x_1(t) - x_2(t)$$

# EXAMPLE 2

## Water level control

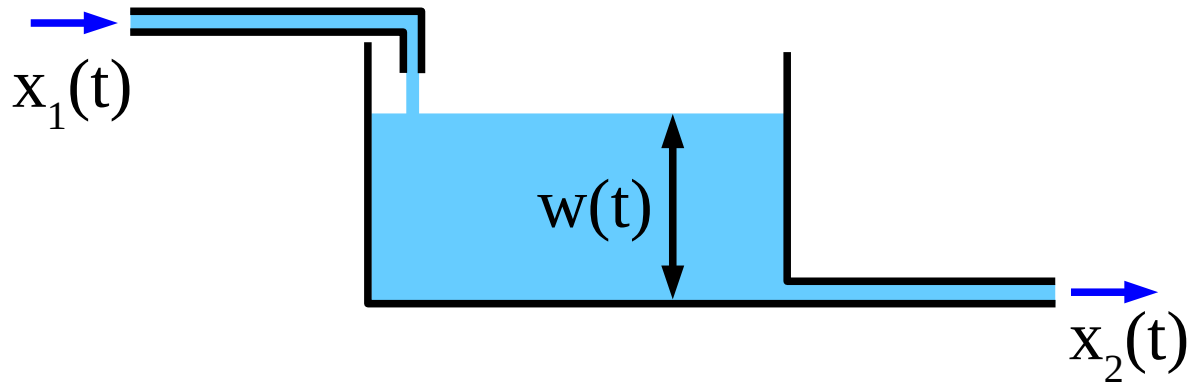

$x_1(t)$  [ $m^3/s$ ] - inflow of a liquid (controlled)

$x_2(t)$  [ $m^3/s$ ] - outflow of a liquid (not controlled)

$w(t)$  [ $m$ ] - level of a liquid in a tank

$A$  [ $m^2$ ] - constant surface area

$$\frac{dv(t)}{dt} = x_1(t) - x_2(t)$$

$$A \frac{dw(t)}{dt} = x_1(t) - x_2(t)$$

$$H(s) = \frac{W(s)}{X_1(s) - X_2(s)} = \frac{1}{As}$$

# EXAMPLE 2

## Water level control

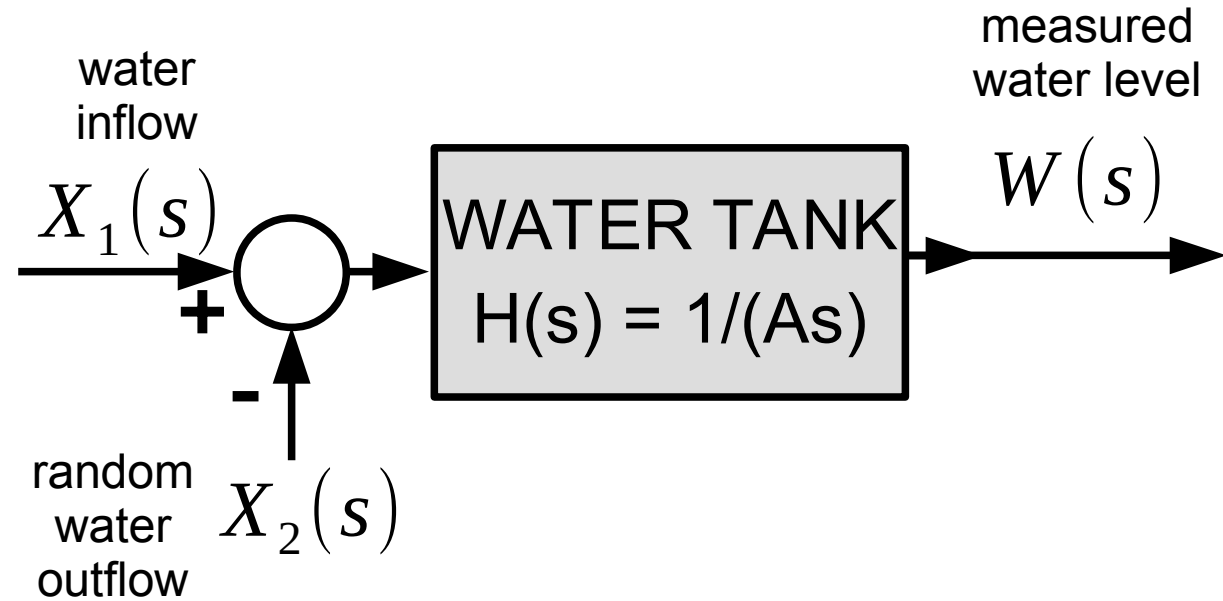

# EXAMPLE 2

## Water level control

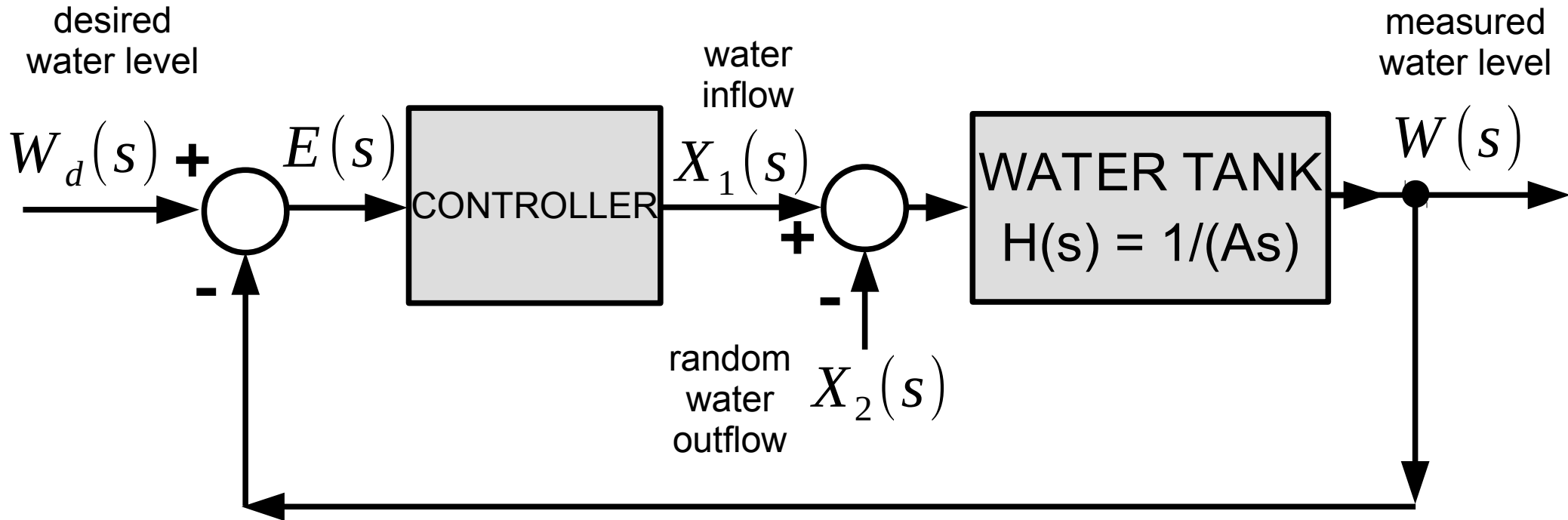

# EXAMPLE 2

## Water level control

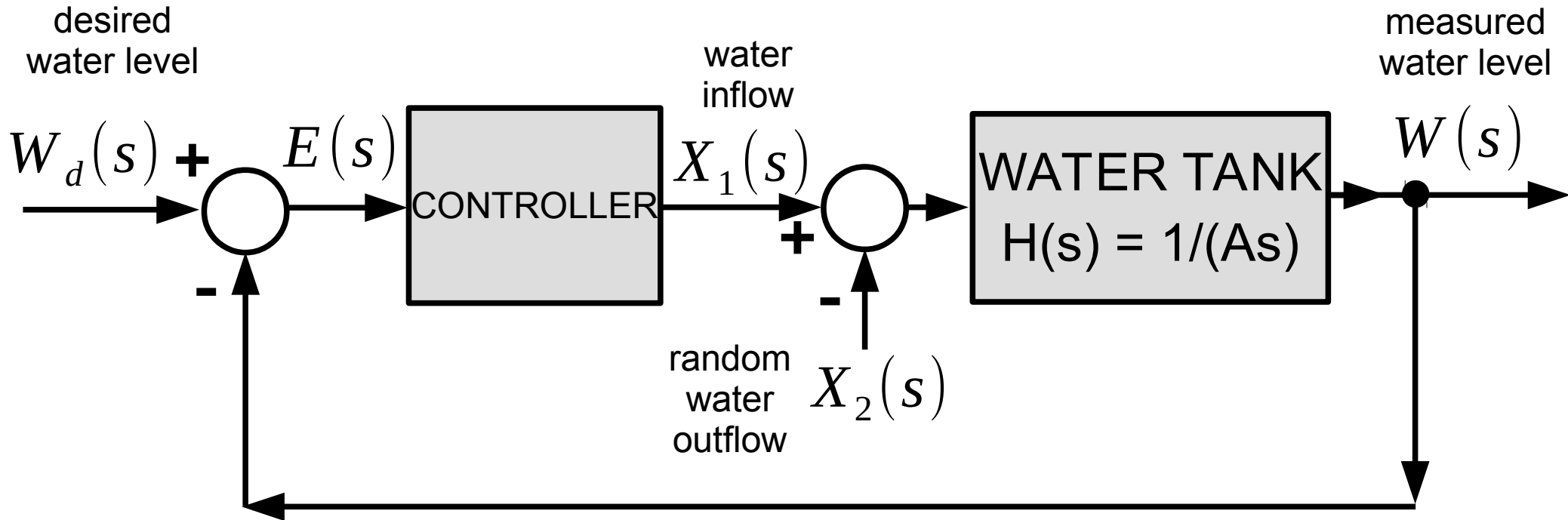

### Proposed controllers:

- ideal on/off controller
- on/off controller with hysteresis
- proportional controller

# EXAMPLE 2

## Water level control

ideal on/off controller

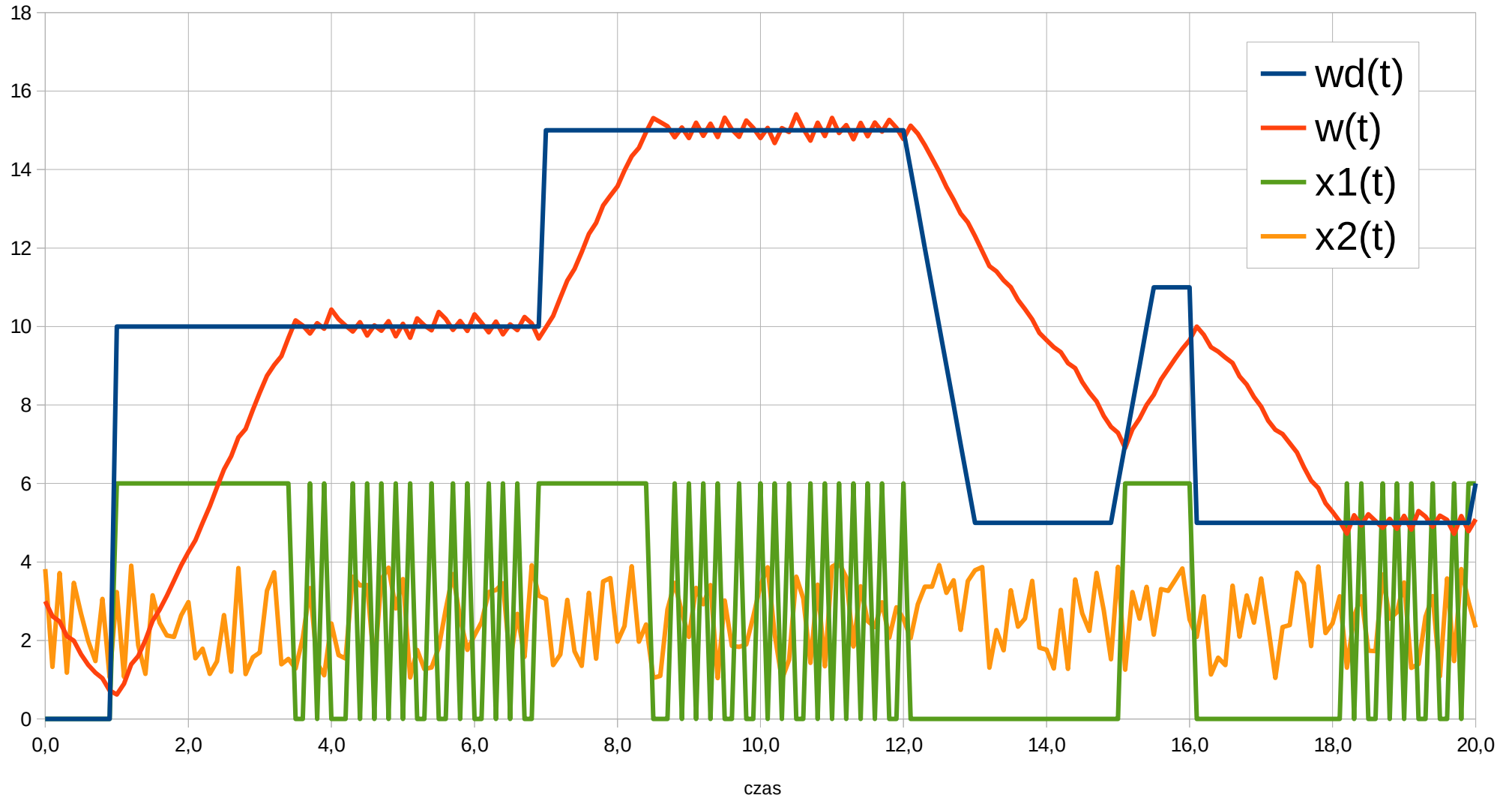



# EXAMPLE 2

## Water level control

on/off controller with hysteresis

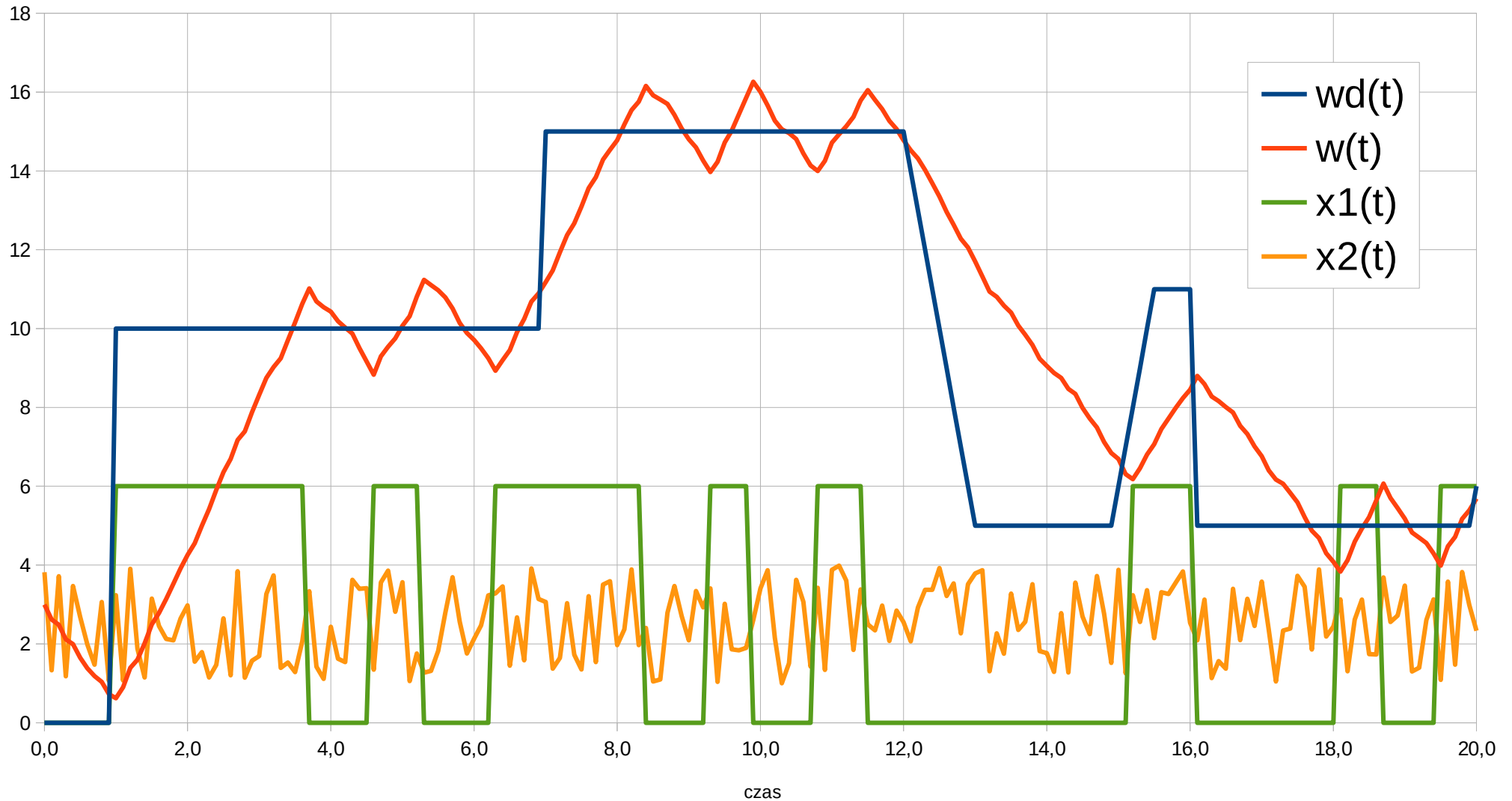

# EXAMPLE 2

## Water level control

proportional controller (small  $k_p$ )

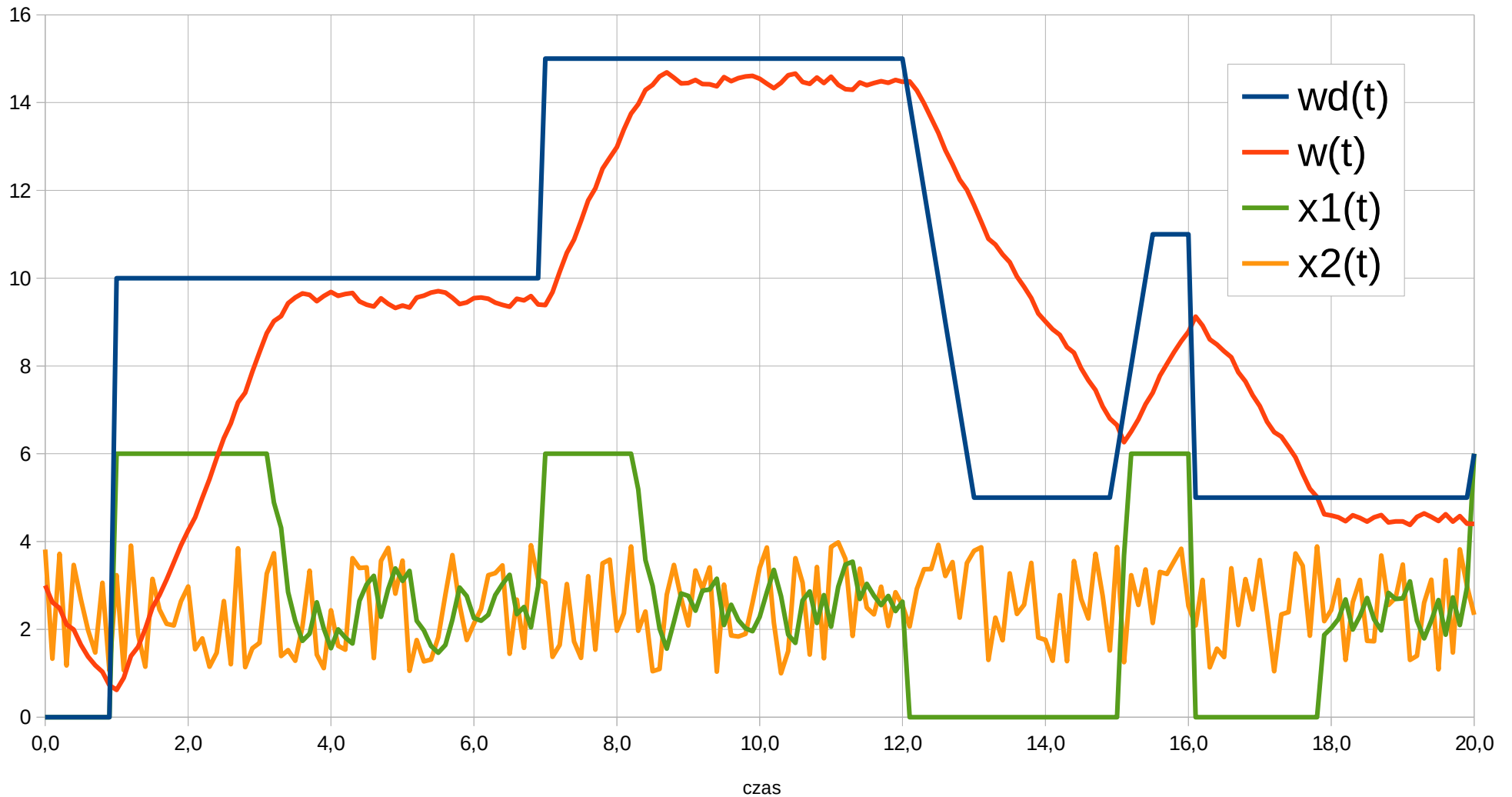

# EXAMPLE 2

## Water level control

proportional controller (high  $k_p$ )

