



Faculty of Automotive and Construction Machinery Engineering

WARSAW UNIVERSITY OF TECHNOLOGY

Theory of Machines and Automatic Control Winter 2019/2020

Lecturer: Sebastian Korczak, PhD Eng.

Lecture 5

Cam-follower mechanisms.
Dynamics of planar mechanisms.

Cam-follower

Inspirations

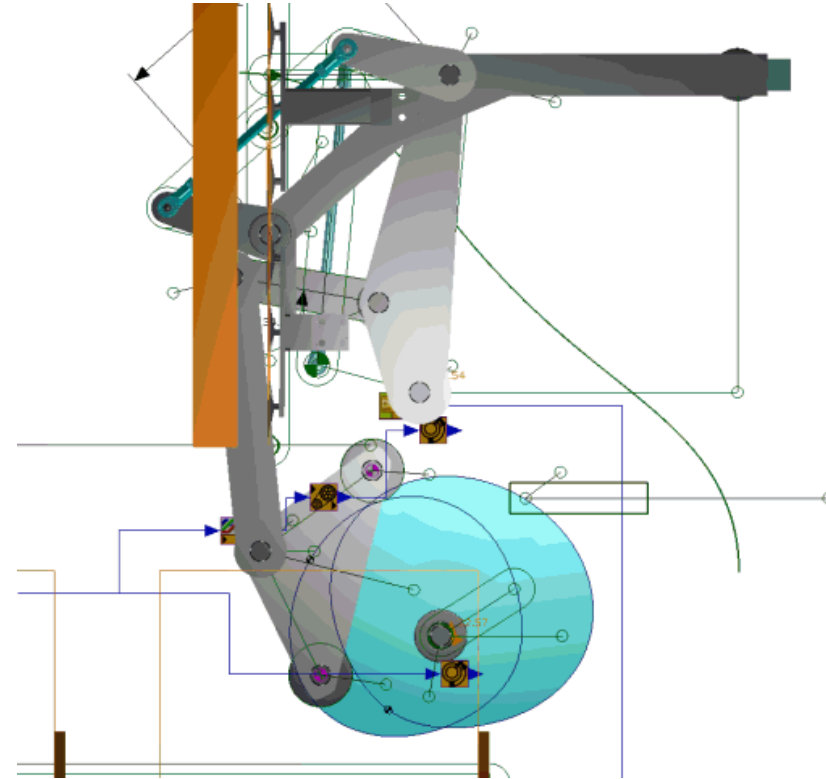
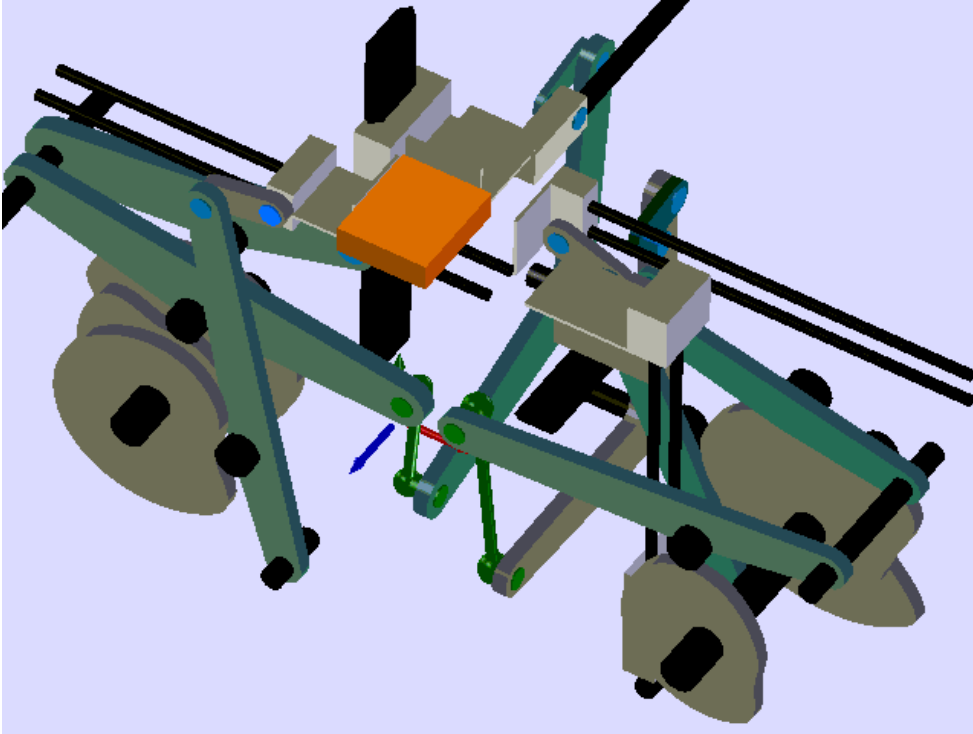

source: psmotion.com

Cam-follower

art inspiration



The "Draughtsman-Writer" automaton by Henri Maillardet
https://en.wikipedia.org/wiki/File:Maillardet%27s_automaton_at_the_Franklin_Institute.webm



Mechanics Alive! Cabaret Mechanical
Theatre Automata Exhibition
<https://www.youtube.com/watch?v=kv1CpJi60xQ>

~1800

Cam-follower

Cam-follower mechanism – mechanism build of a cam and a follower (tappet) connected as a IV class kinematic pair.

Cam is rotating (sometimes is translating)

follower is reciprocating (sometimes is swinging/oscillating)

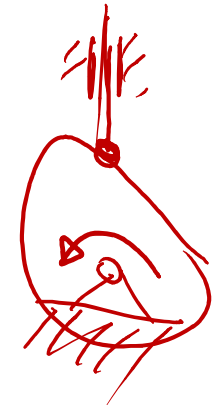

advantages

- simple to construction,
- simple to create,
- any dimensions,
- simple to create advanced motions.

disadvantages

- no adaptation possible.

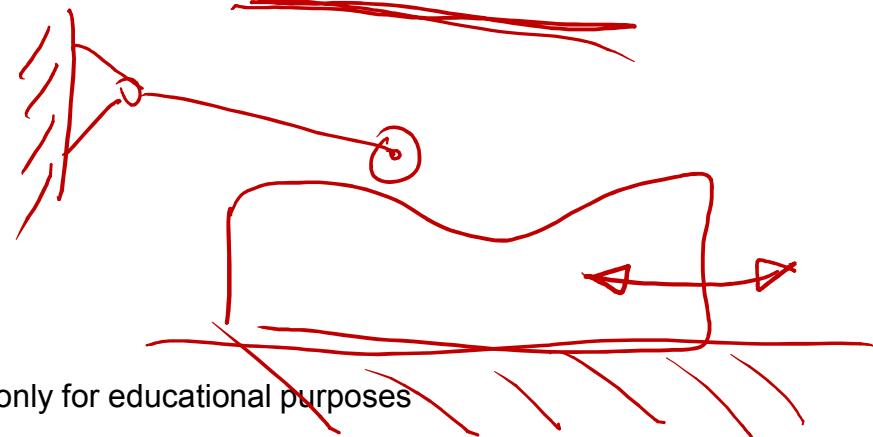

Cam-follower

Classification

2D 3D

- flat / spatial
- with in-line (central) follower / with offset (eccentric) follower
- closed with geometry / closed with force

Cam-follower

Followers

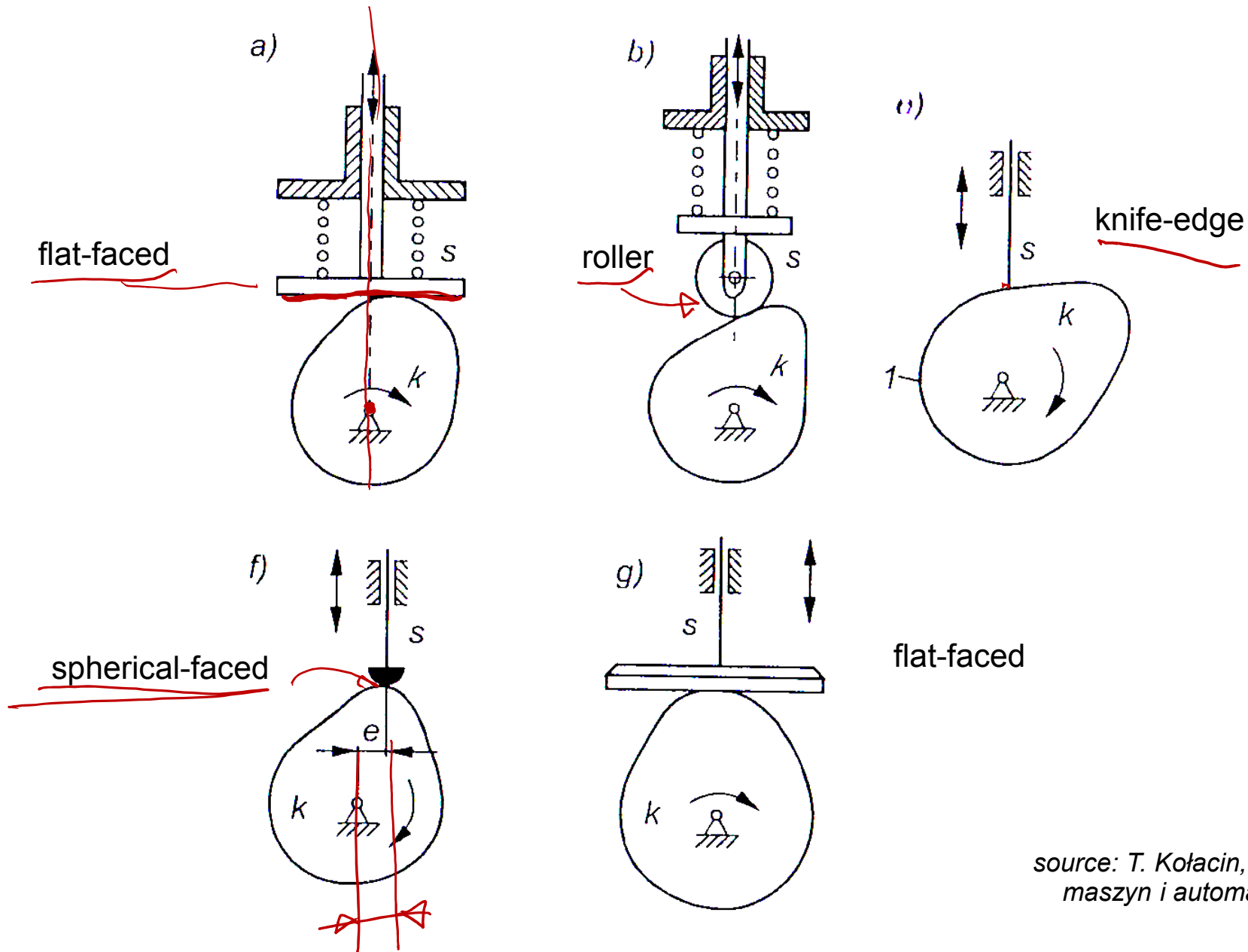

source: T. Kołacin, „Podstawy teorii maszyn i automatyki”, OW PW

Cam-follower

Followers

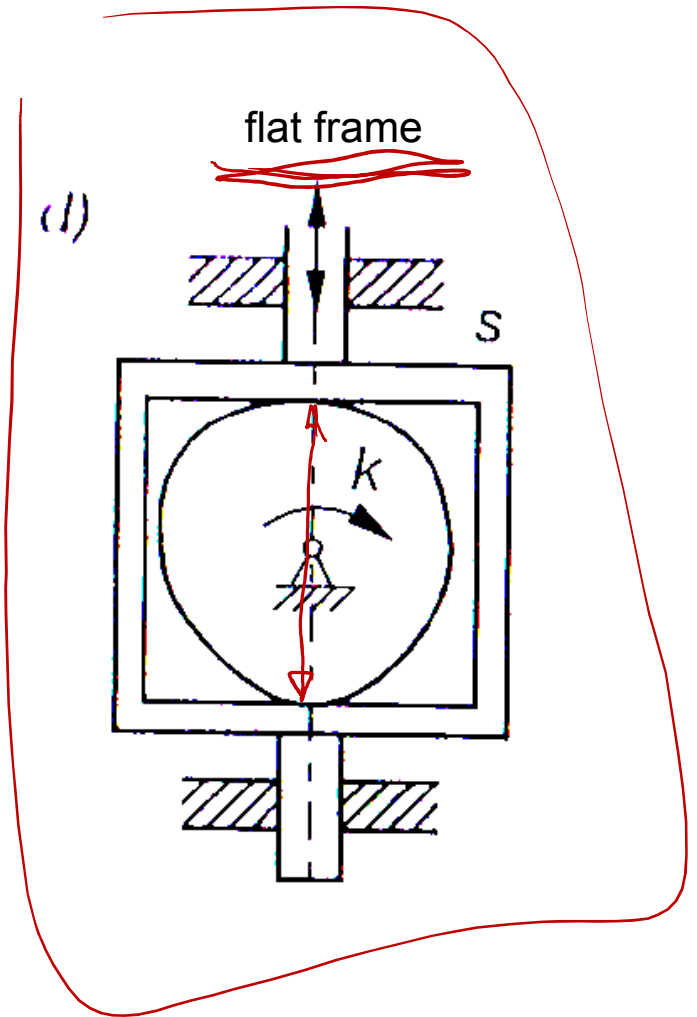
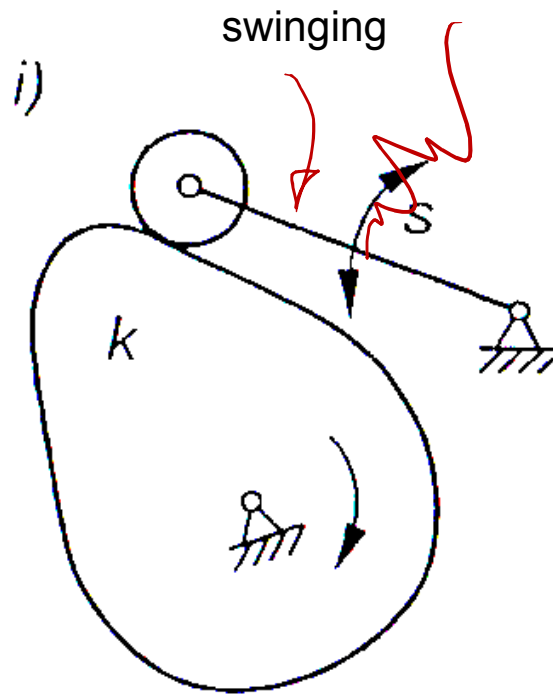
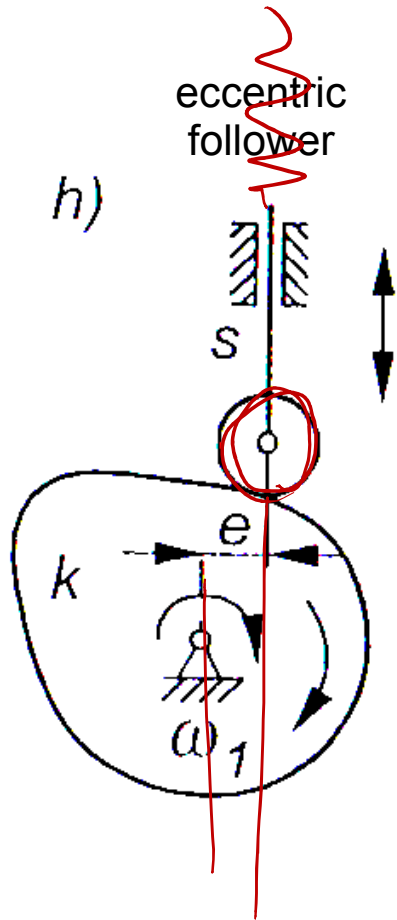

source: T. Kołacin, „Podstawy teorii maszyn i automatyki”, OW PW

Cam-follower

examples

3D

cylindrical cam

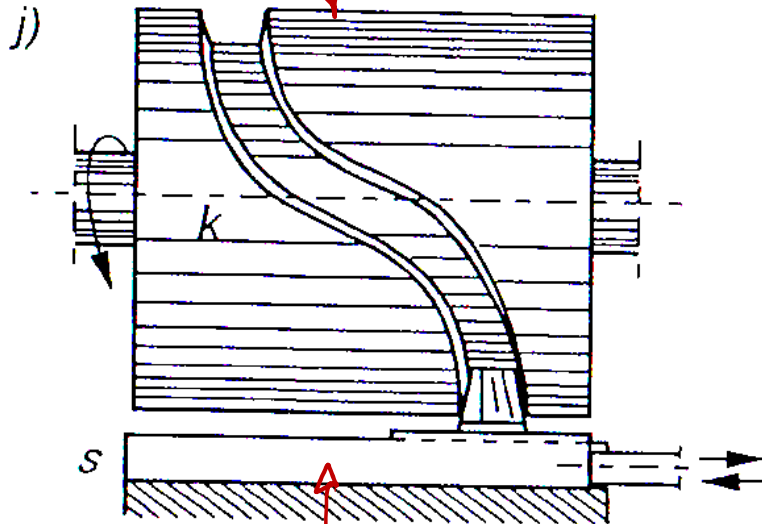

transl. foll.

c)

translating cam

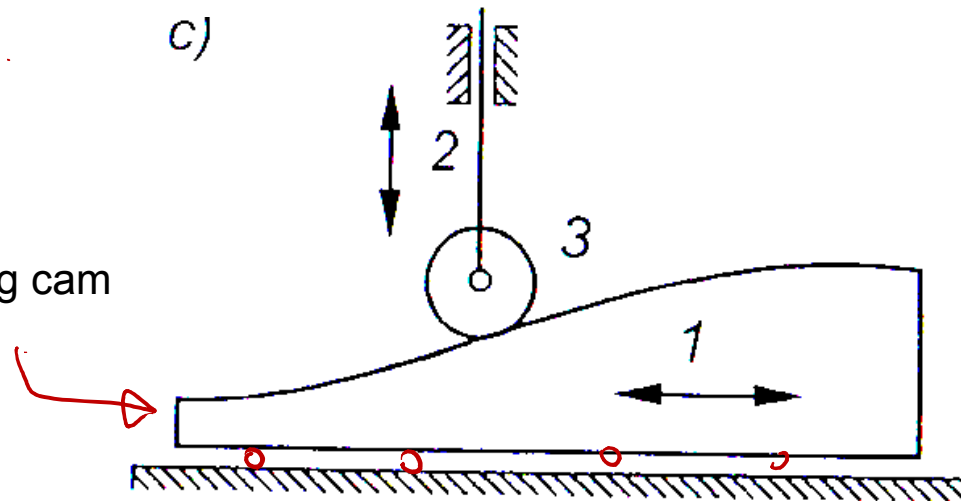

k)

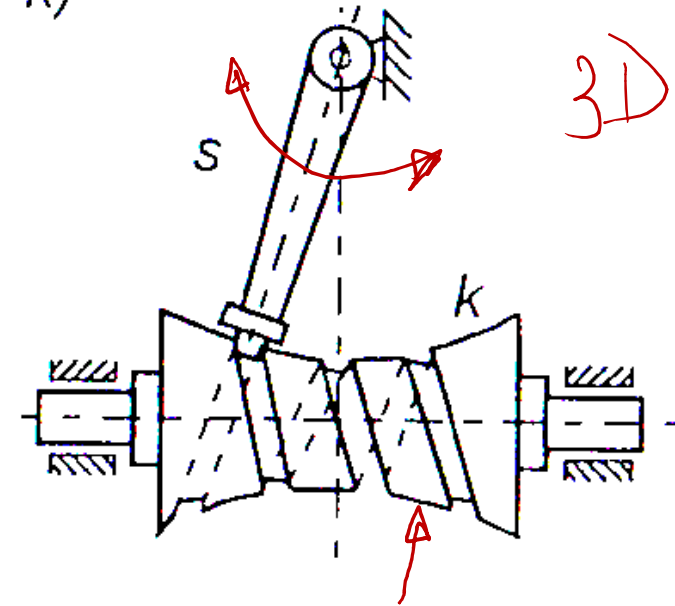



3D

globoidal cam

source: T. Kołacin, „Podstawy teorii maszyn i automatyki”, OW PW

Analysis and synthesis of cam-follower mechanism

 Analysis – calculation of displacement, velocity and acceleration functions for a follower motion with respect to a cam's rotations angle for arbitrary given geometry.

 Synthesis – calculation of a cam geometry needed to obtain given displacement/velocity/acceleration functions. Limitations must be included, i.e. some maximum values, geometry limitations and jerk values (third derivative).

Analysis and synthesis of cam-follower mechanisms

<u>Analysis</u>	<u>Syntesis</u>
<p><i>graph.</i></p> <ol style="list-style-type: none">1 substitution of IV. class kinematic pair with V. class kinematic pairs + graphical method (velocity and acceleration scheme)2 graphical determination of a follower movement and graphical differentiation <ul style="list-style-type: none">• analytical method (substitution with polygones of vectors)	<ul style="list-style-type: none">• graphical determination of cam outline by a base circle rotation with follower movement• analytical designing with a function description

Analysis of a cam-follower mechanism

1 Graphical method with IV. class kinematic pair substitution with V. class kinematic pairs.

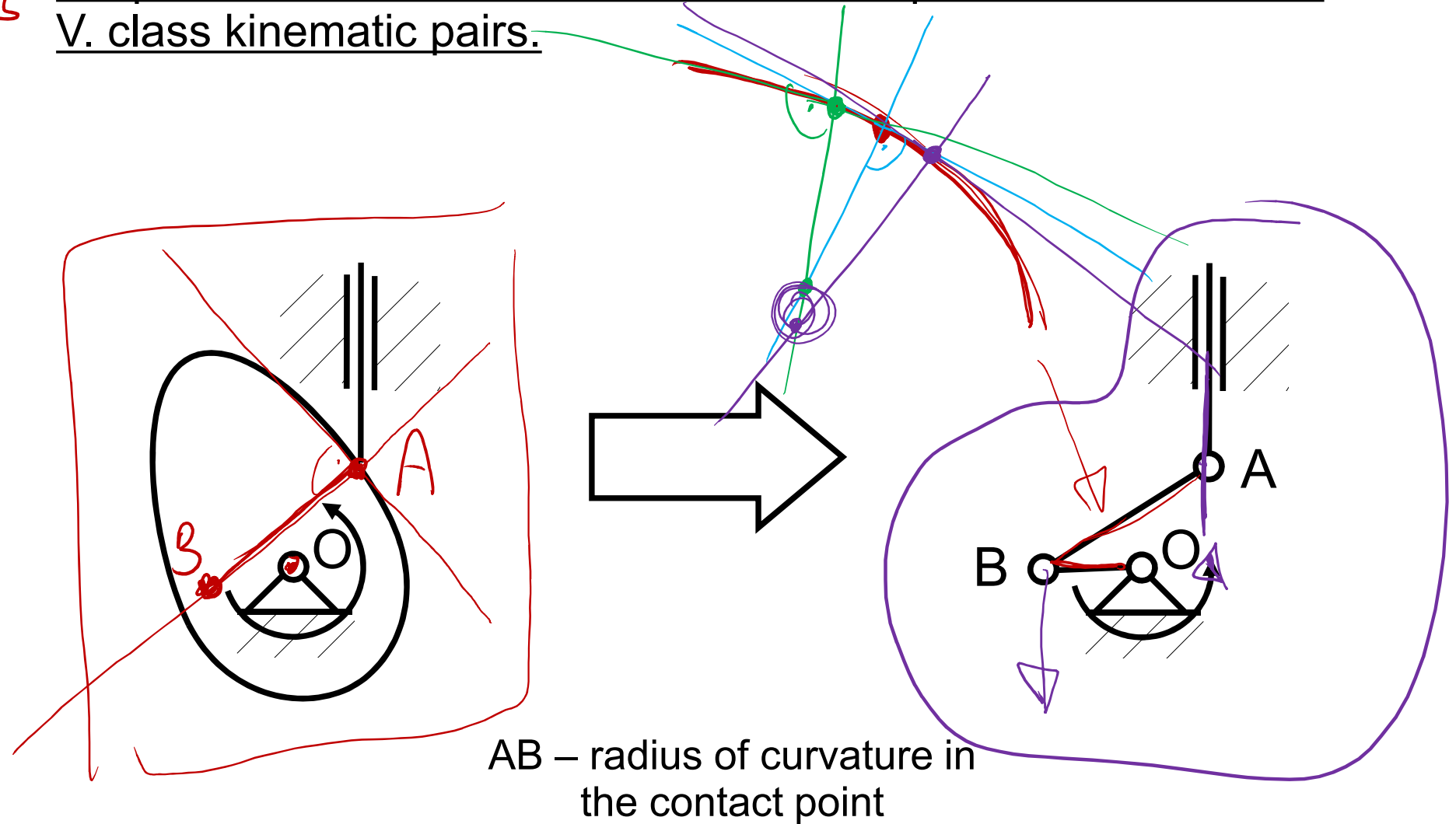

Analysis of a cam-follower mechanism

Graphical method with IV. class kinematic pair substitution with V. class kinematic pairs.

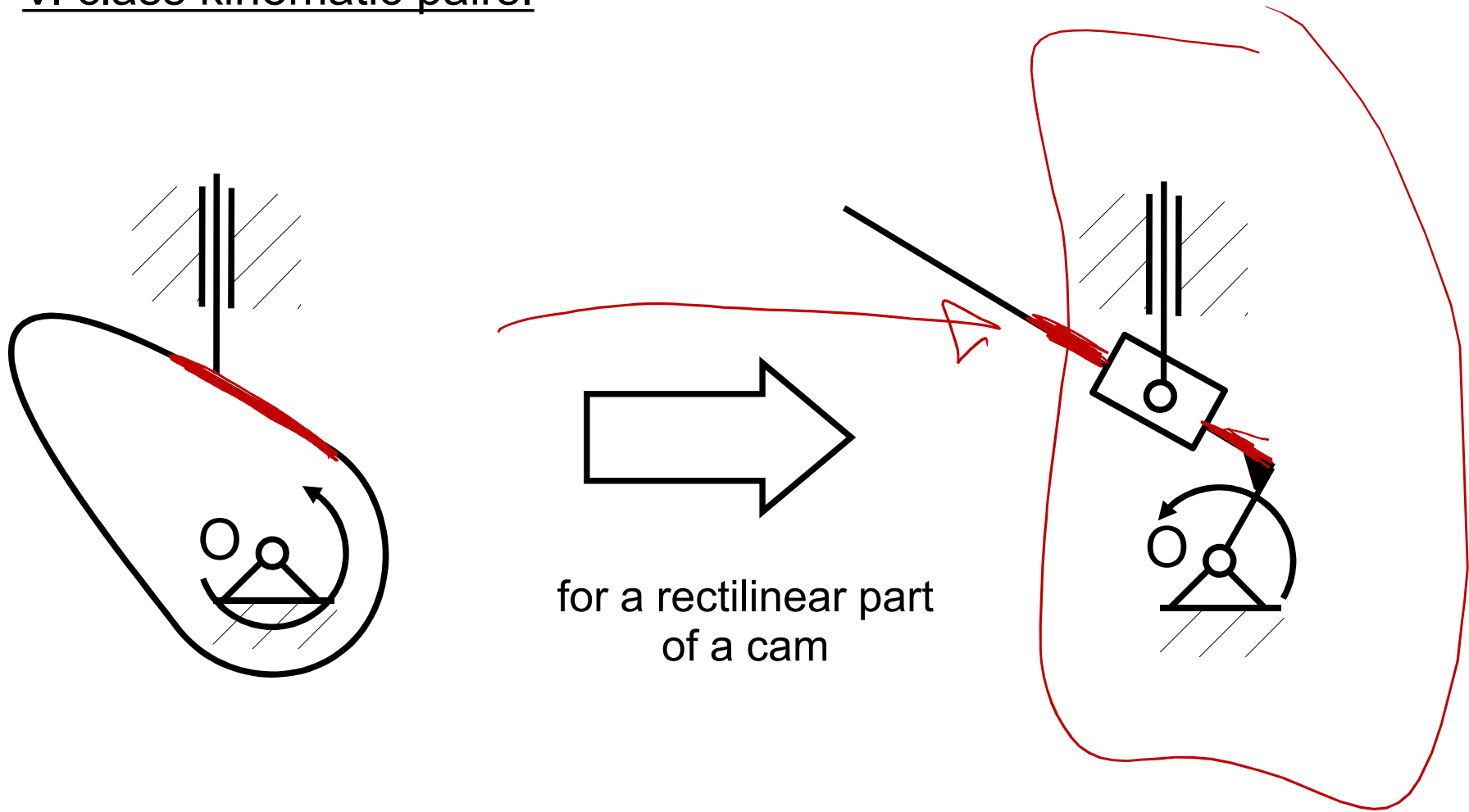

Analysis of a cam-follower mechanism

2. Graphical determination of a follower movement

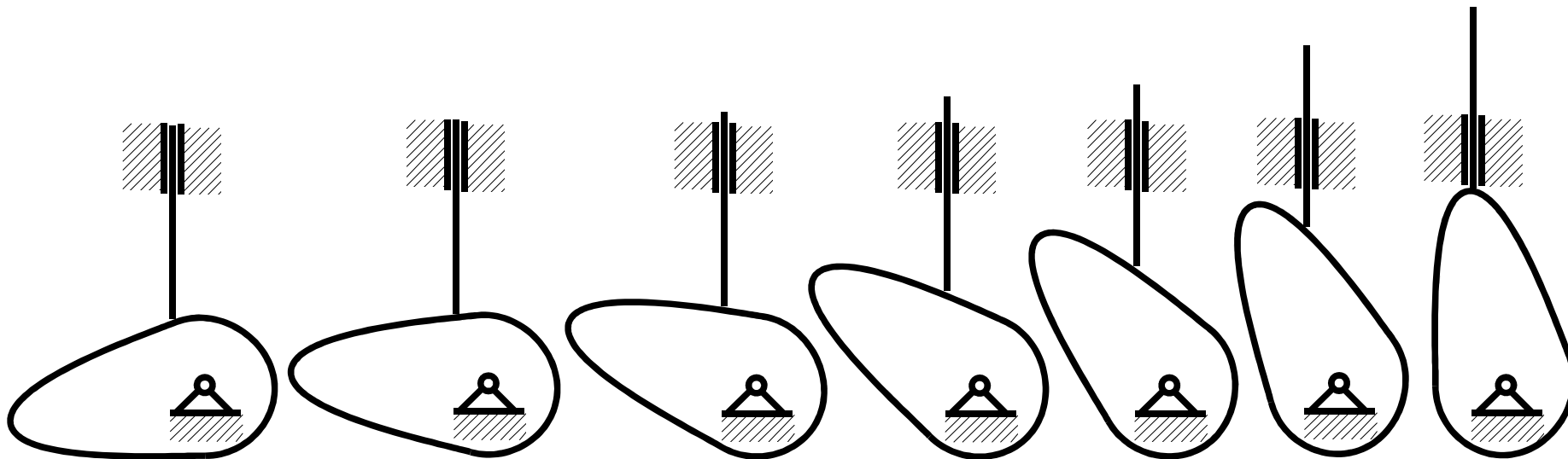

Analysis of a cam-follower mechanism

Graphical determination of a follower movement

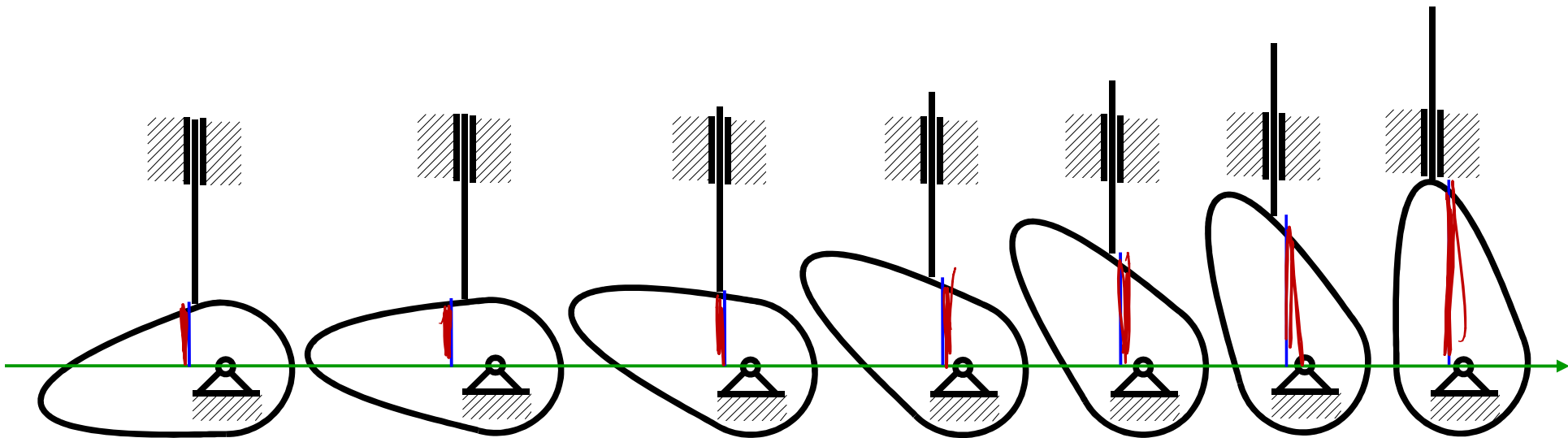

Analysis of a cam-follower mechanism

Graphical determination of a follower movement

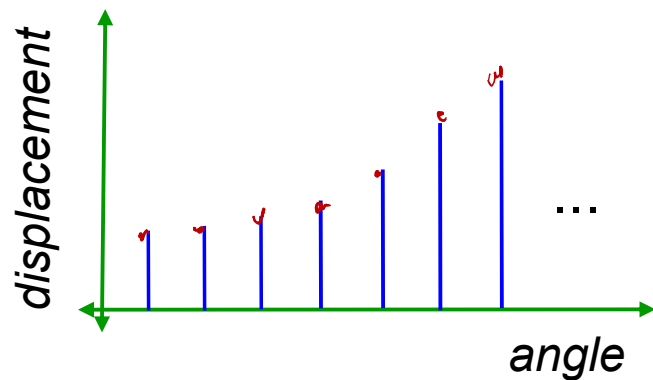
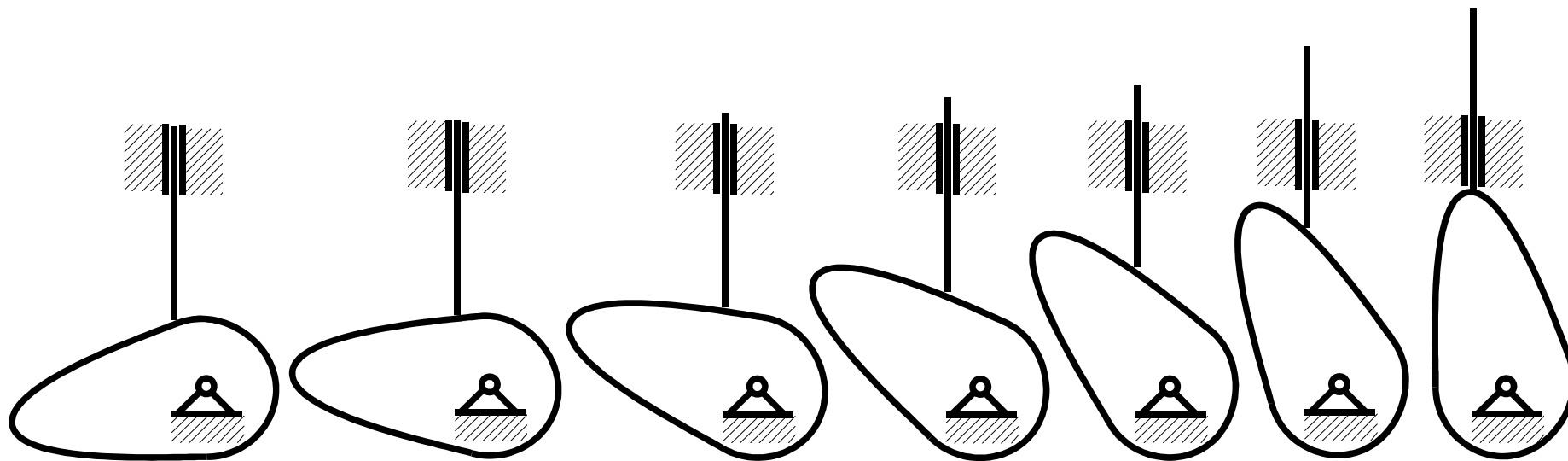

Analysis of a cam-follower mechanism

Graphical determination of a follower movement

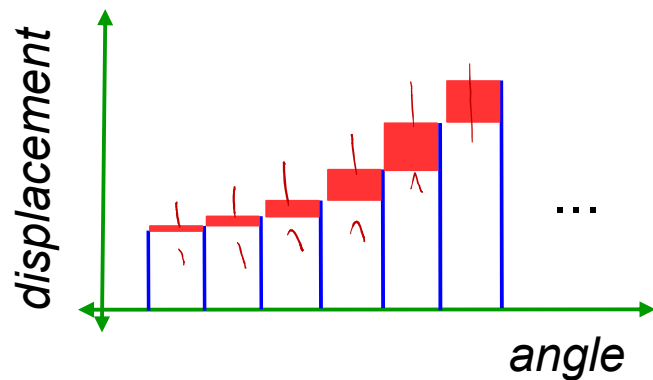
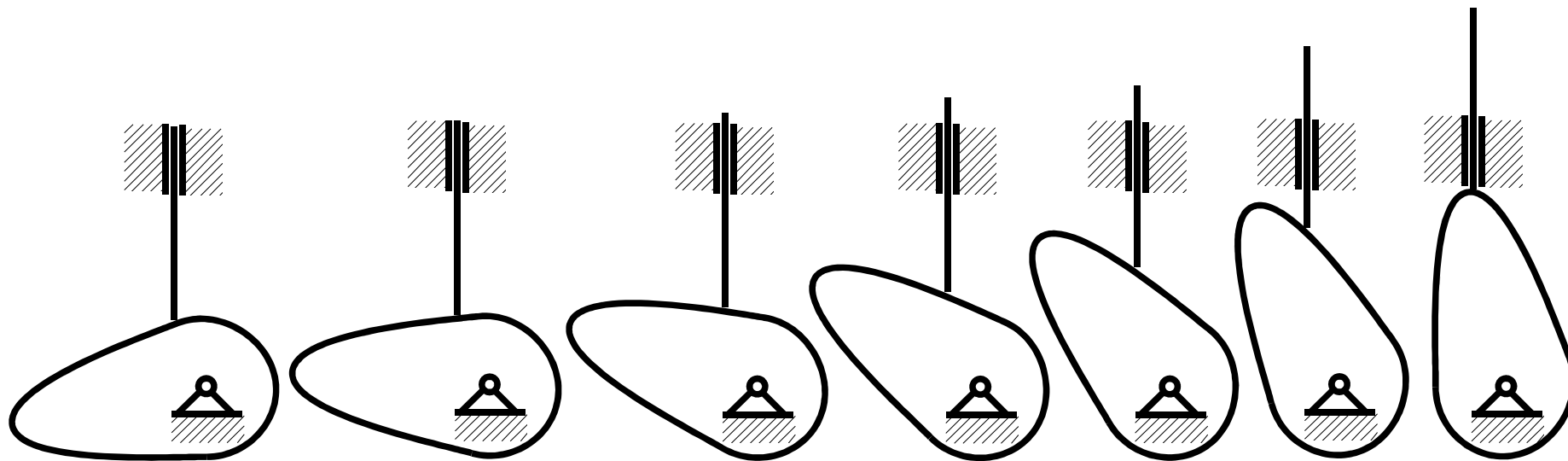

Analysis of a cam-follower mechanism

Graphical determination of a follower movement

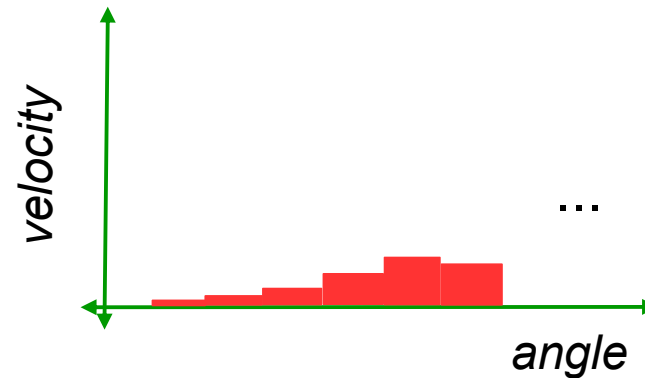
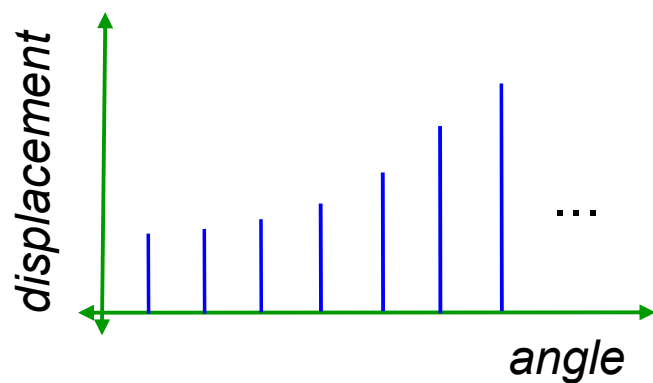
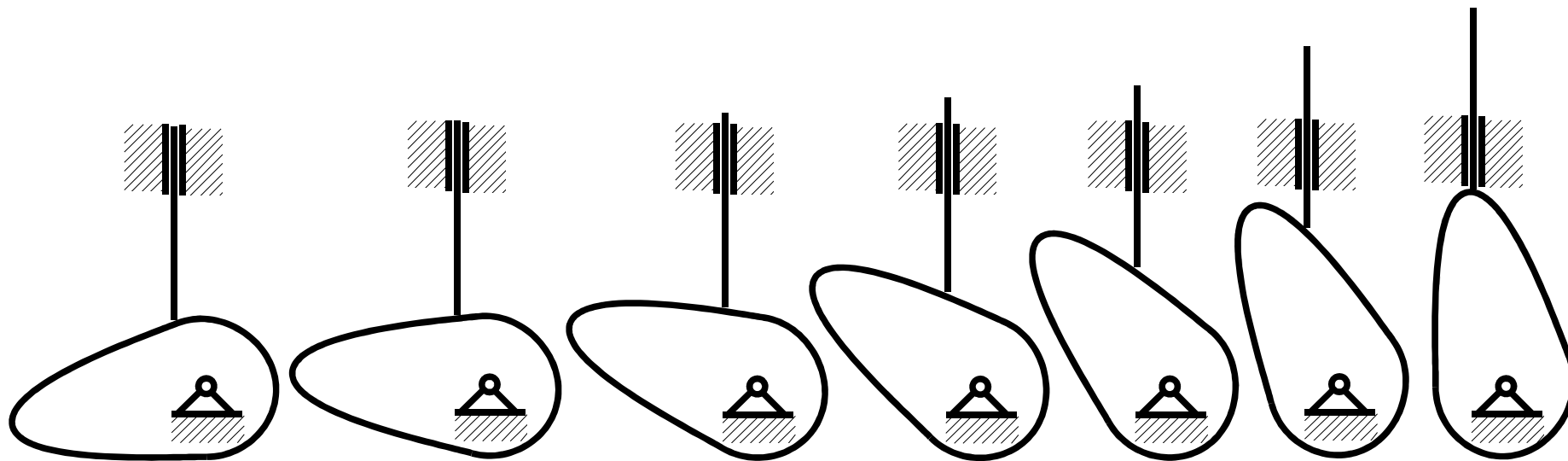

Analysis of a cam-follower mechanism

Graphical determination of a follower movement

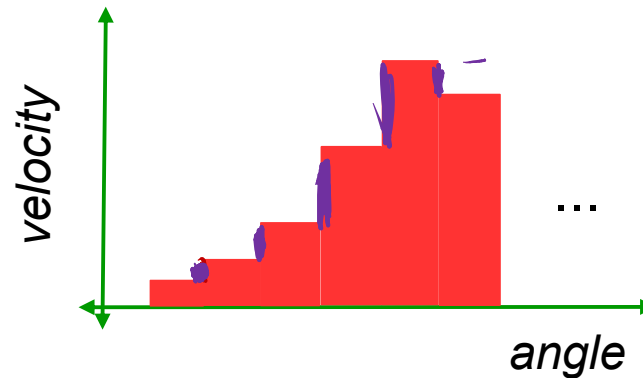
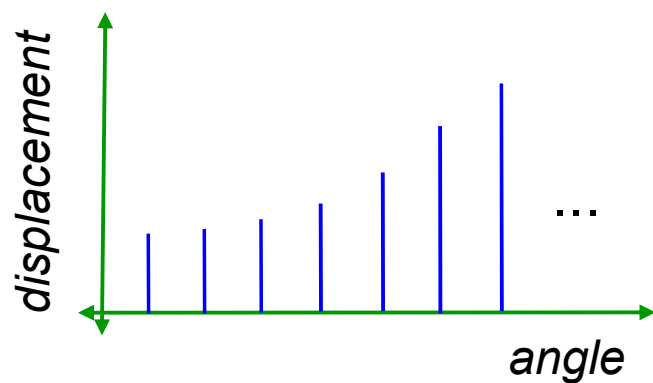
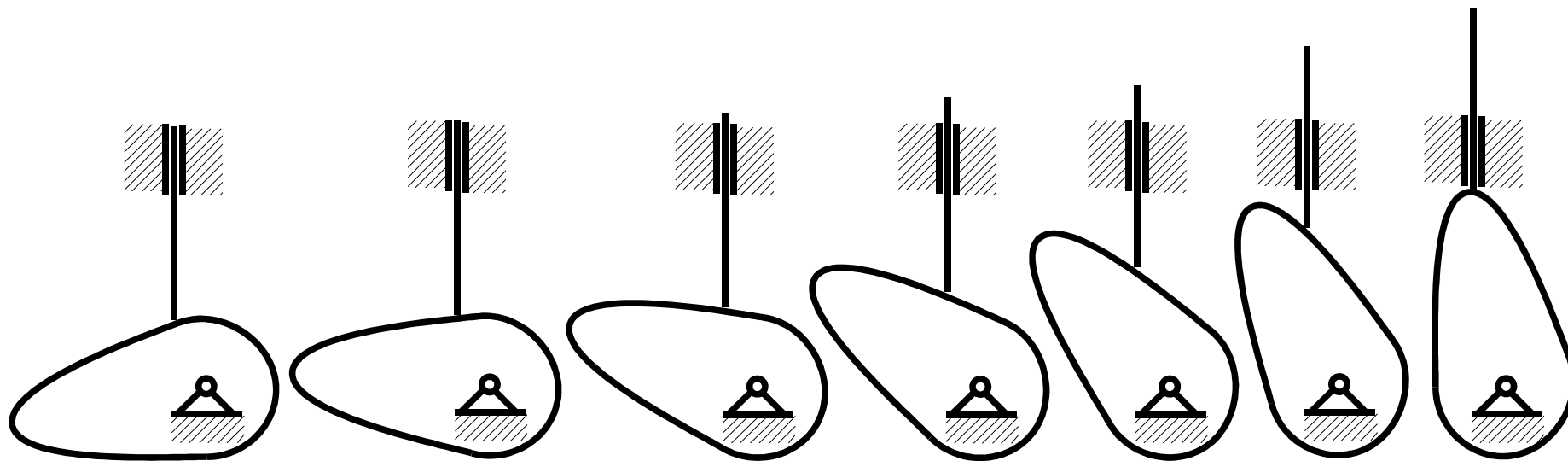

Analysis of a cam-follower mechanism

Graphical determination of a follower movement

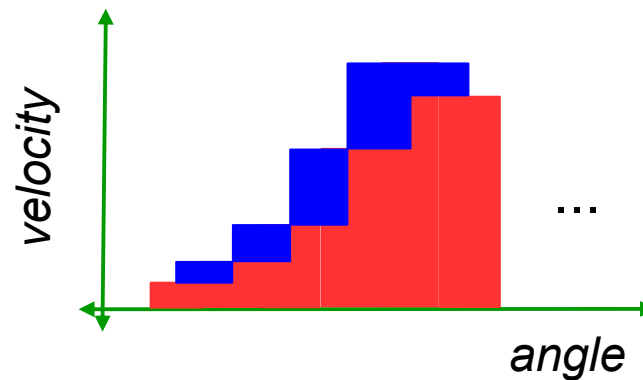
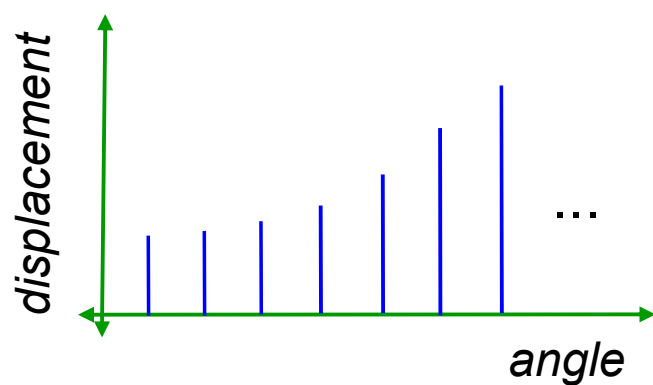
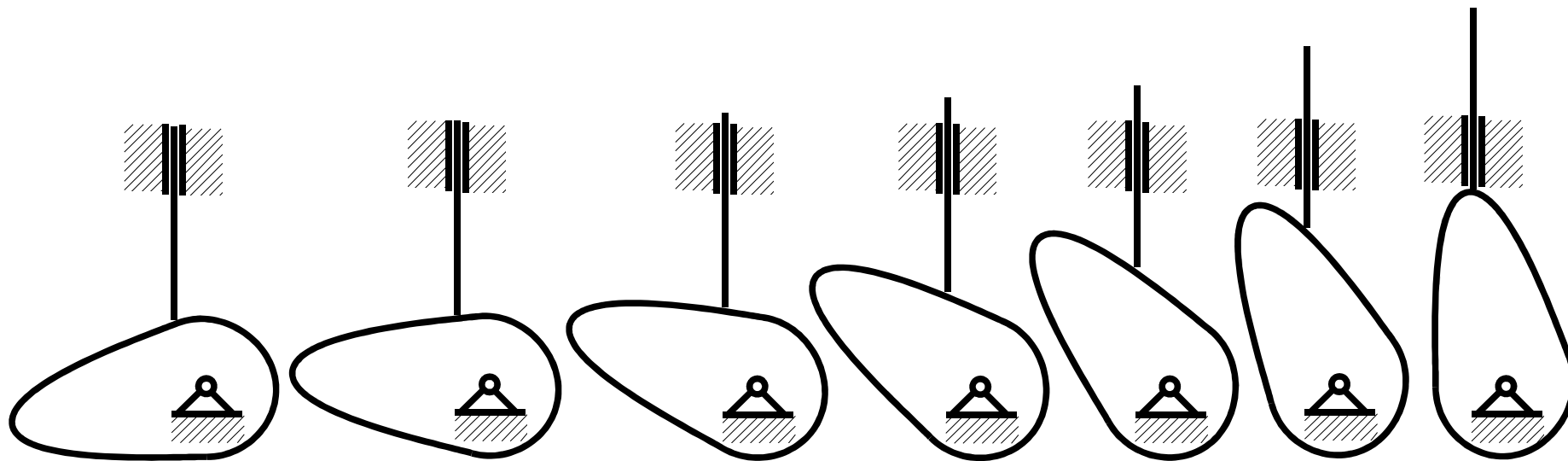

Analysis of a cam-follower mechanism

Graphical determination of a follower movement

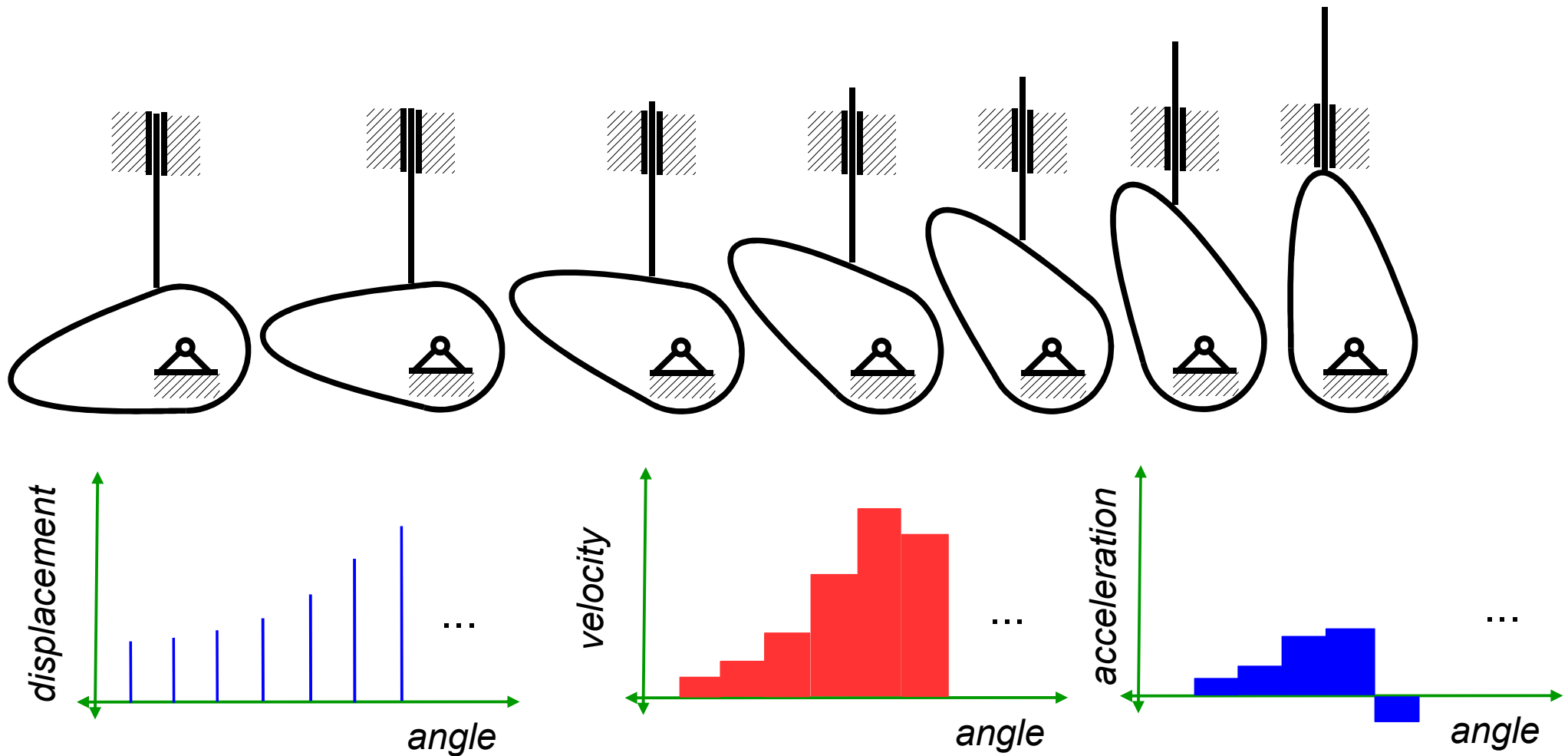

Analysis of a cam-follower mechanism

Graphical determination of a follower movement

$\varphi(t) = \omega \cdot t$
angl'e

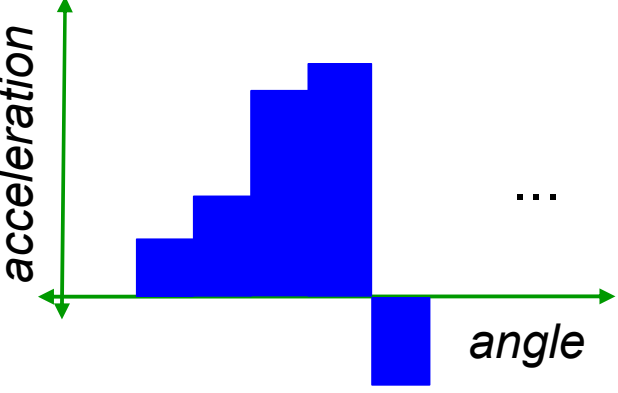
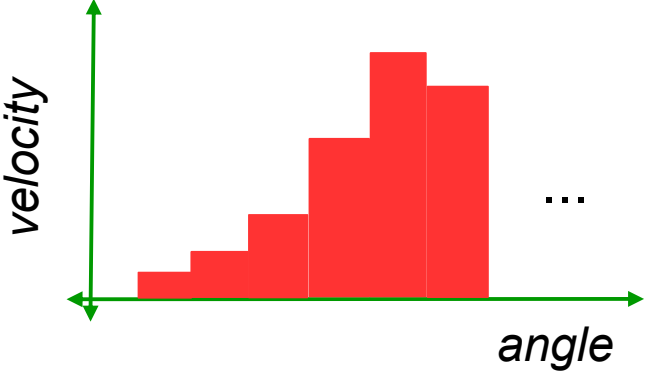
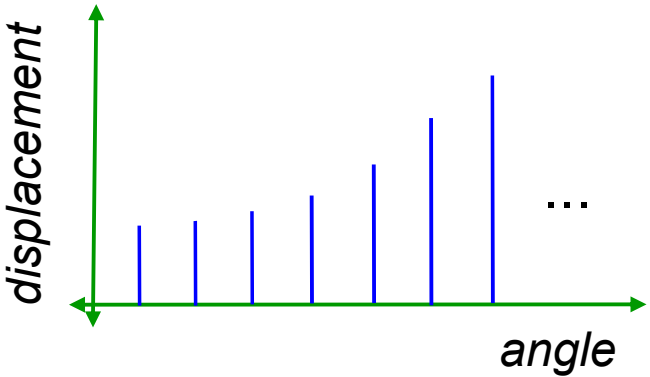
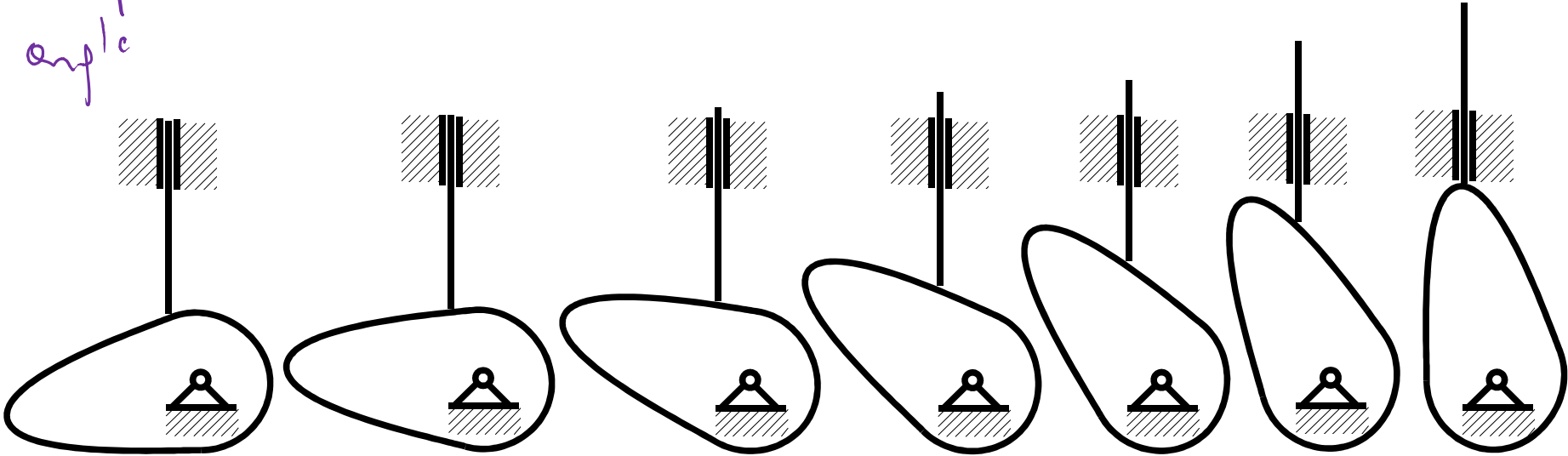

Analysis of a cam-follower mechanism

$$\bar{e} + \bar{r} + \bar{f} = \bar{h}$$

$$|\bar{e}| = e - \text{const. given}$$

$$|\bar{r}| = R - \text{const. given}$$

$$|\bar{f}| = f - \text{const. given}$$

$$|\bar{h}| = h(t) - \text{unknown!}$$

$$\varphi_h = 90^\circ$$

$$\varphi_f = 0^\circ$$

$$\varphi_e(t) - \text{given}$$

$\varphi_r(t)$ - unknown

Analytical method - example

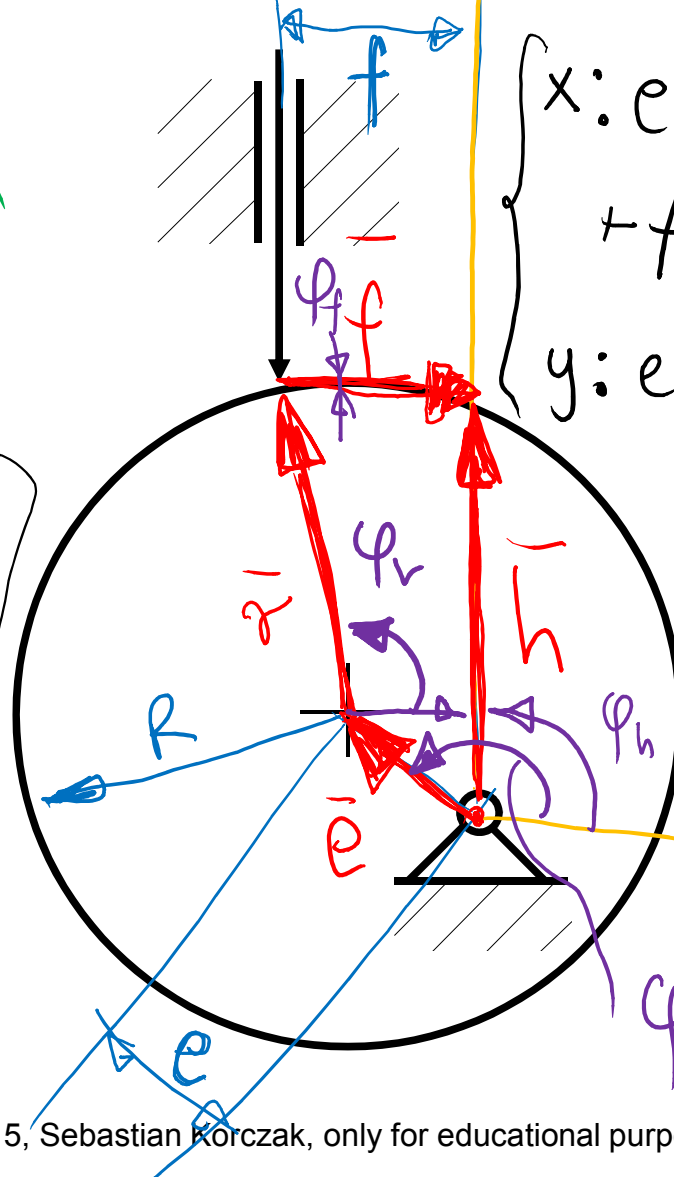

$$\begin{cases} x: e \cos \varphi_e(t) + R \cos \varphi_r(t) + f \cos 0^\circ = h(t) \cos 90^\circ \\ y: e \sin \varphi_e(t) + R \sin \varphi_r(t) + f \sin 0^\circ = h(t) \sin 90^\circ \end{cases}$$

$$h(t) = \dots$$

Synthesis of cam-follower mechanisms

Graphical method

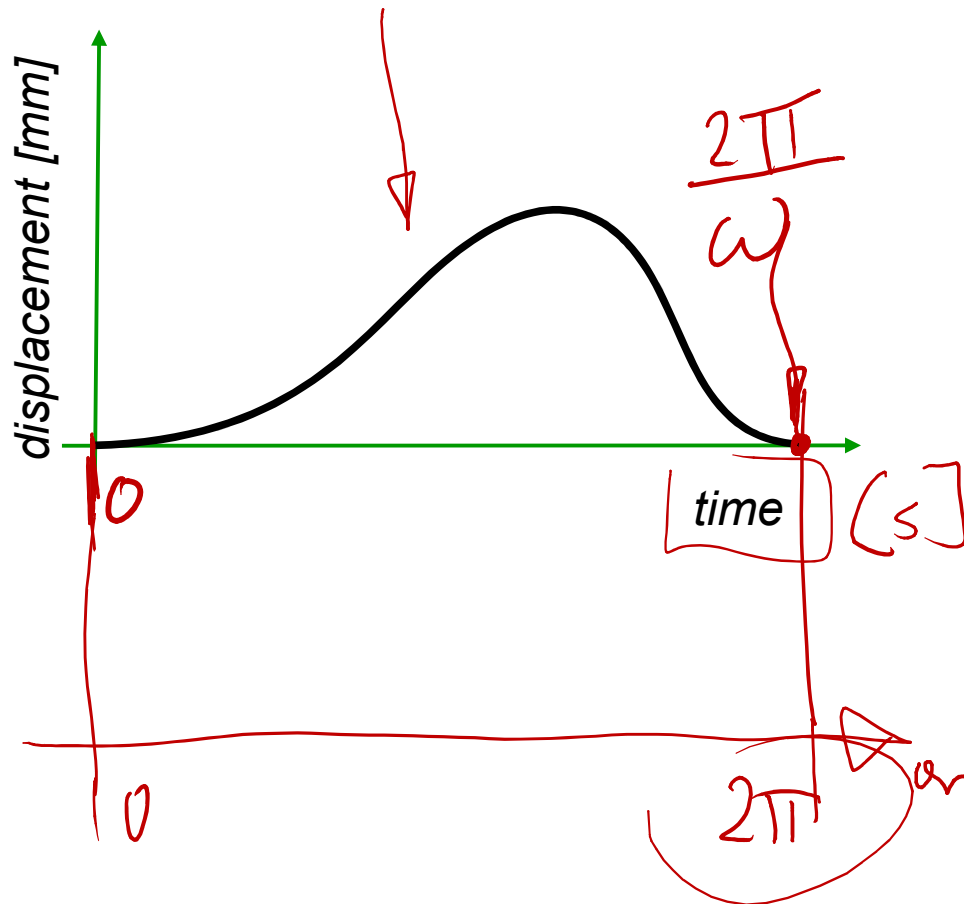

$$\text{if } \varphi(t) = \omega \cdot t$$

$$2\pi = \omega \cdot t_{\text{period}}$$

$$\frac{\text{rad}}{\text{s}}$$

Synthesis of cam-follower mechanisms

Graphical method

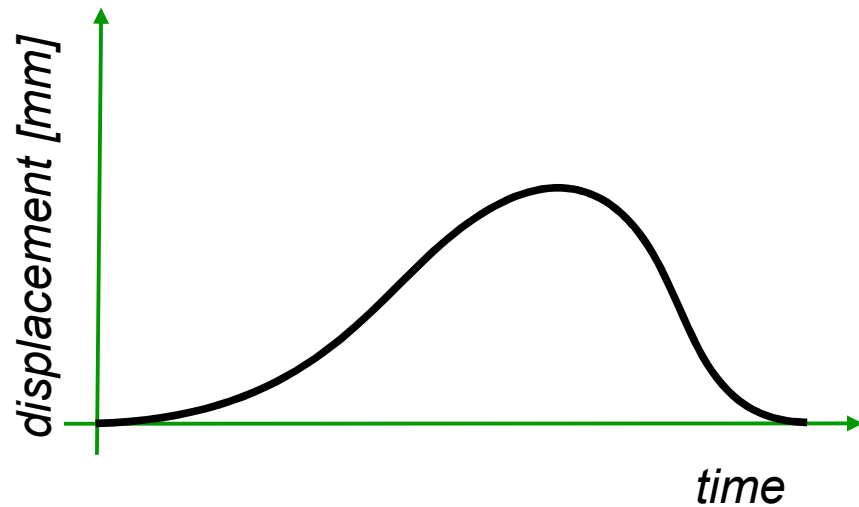

Assumption: constant
angular velocity of a cam

$$\varphi(t) = \omega t$$

Synthesis of cam-follower mechanisms

Graphical method

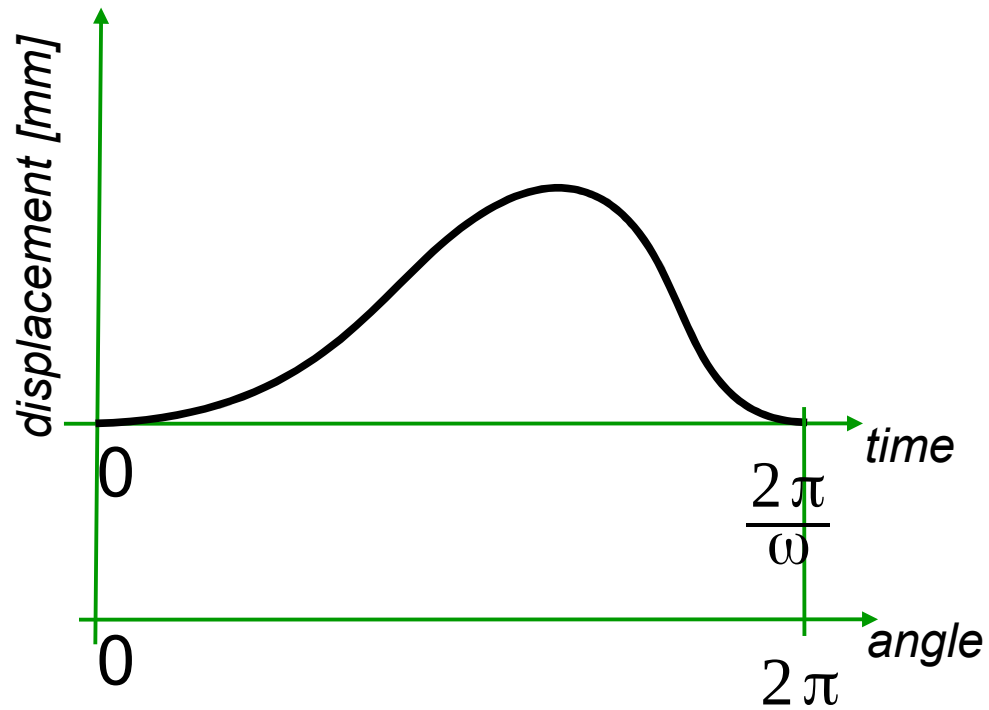

Synthesis of cam-follower mechanisms

Graphical method

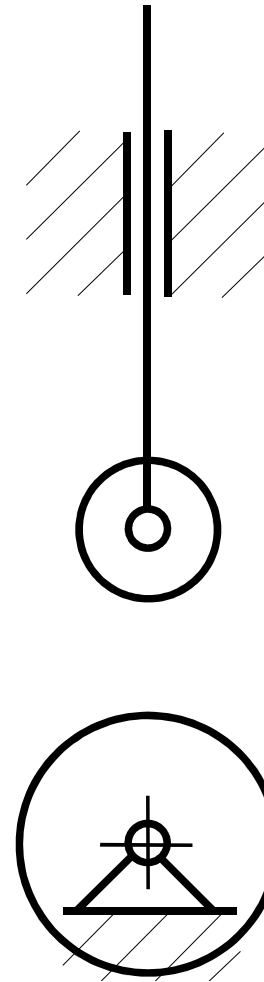

Synthesis of cam-follower mechanisms

Graphical method

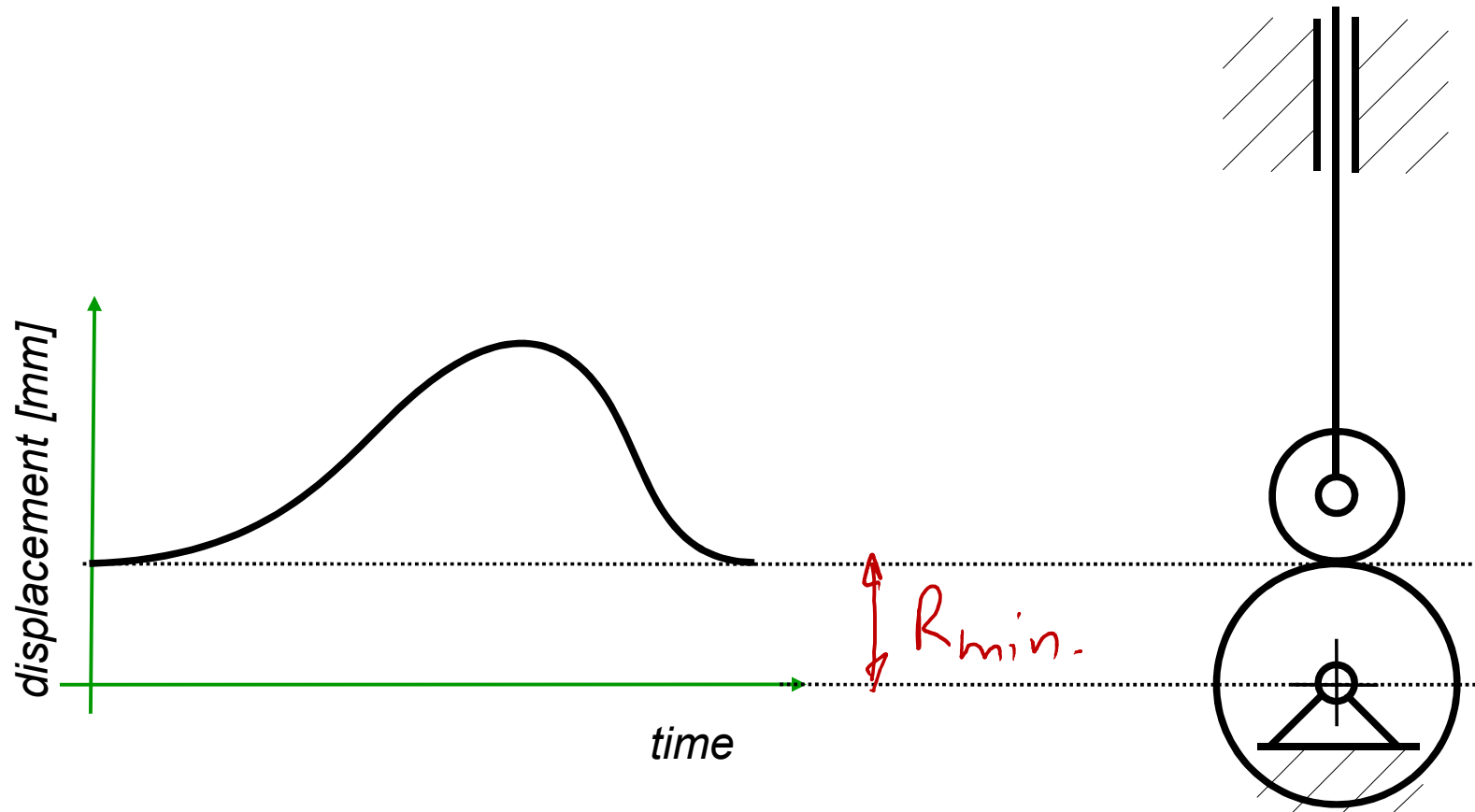

Synthesis of cam-follower mechanisms

Graphical method

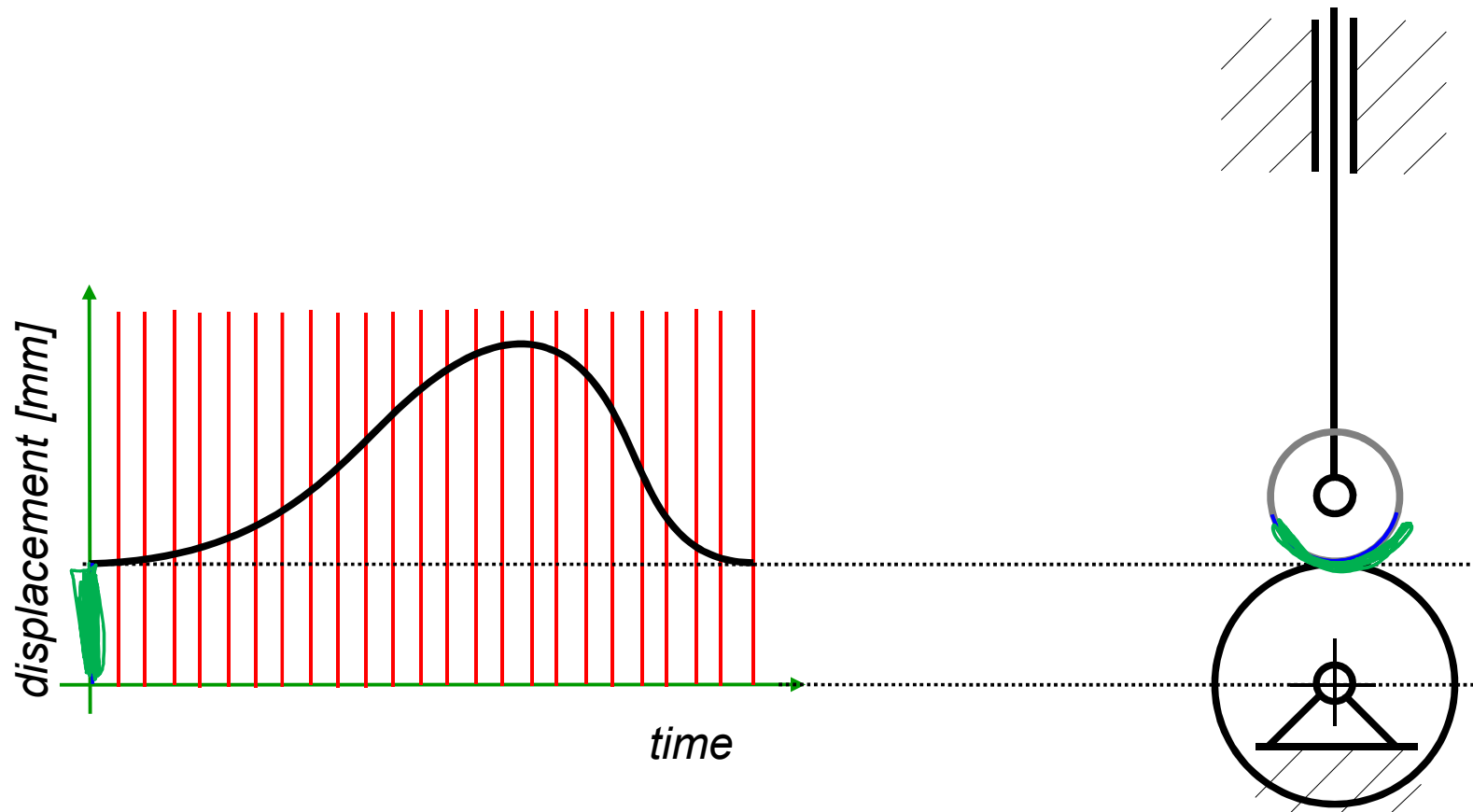

Synthesis of cam-follower mechanisms

Graphical method

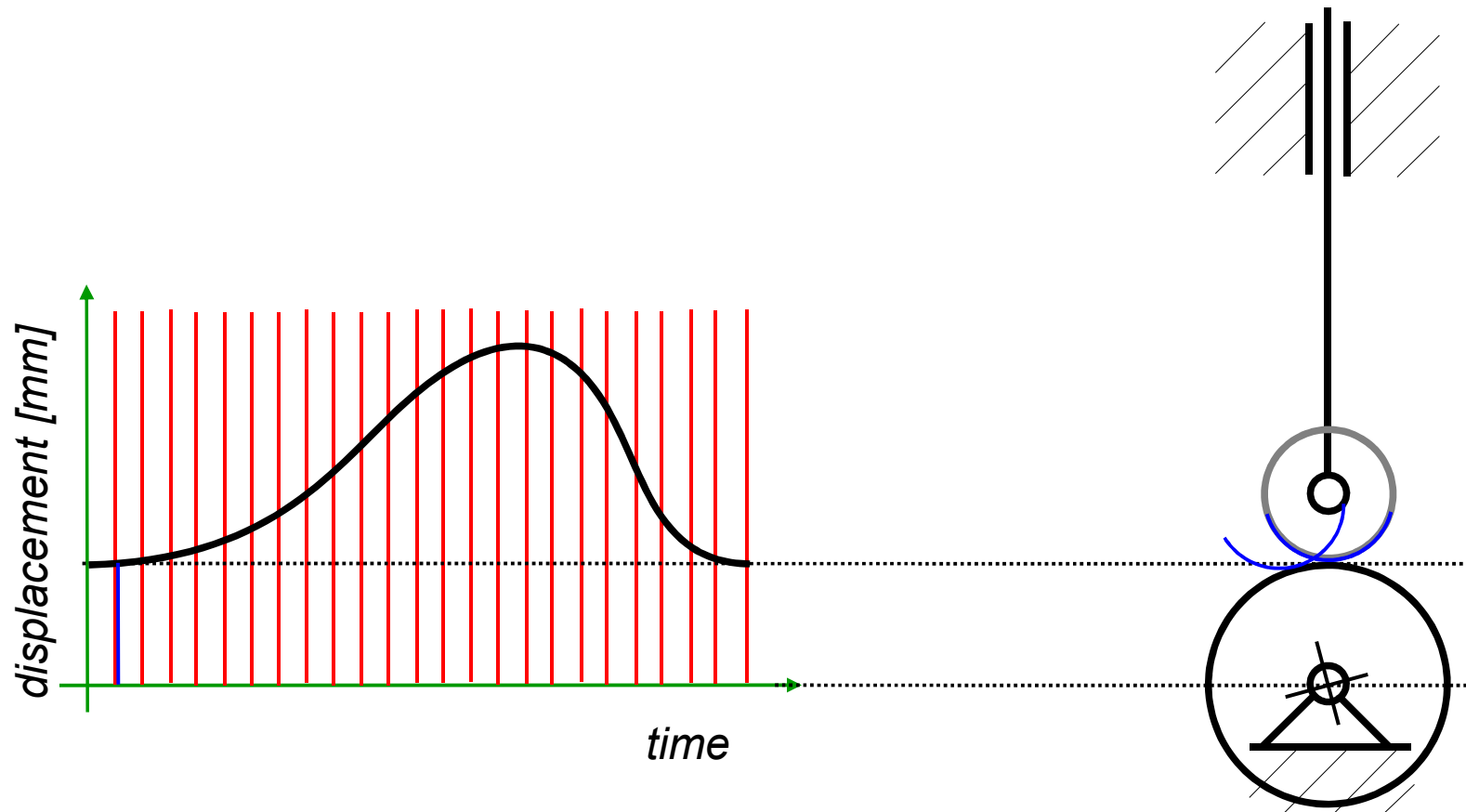

Synthesis of cam-follower mechanisms

Graphical method

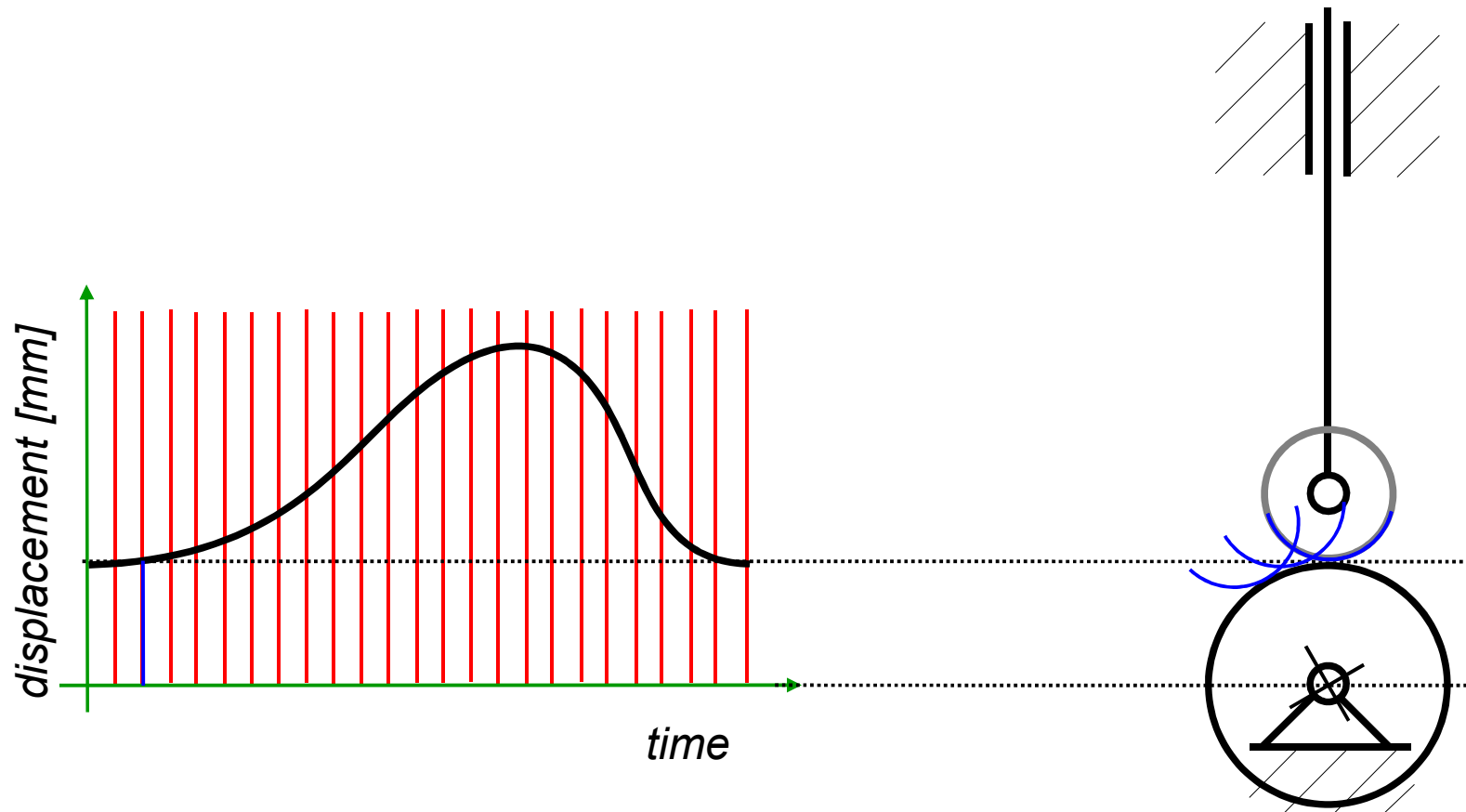

Synthesis of cam-follower mechanisms

Graphical method

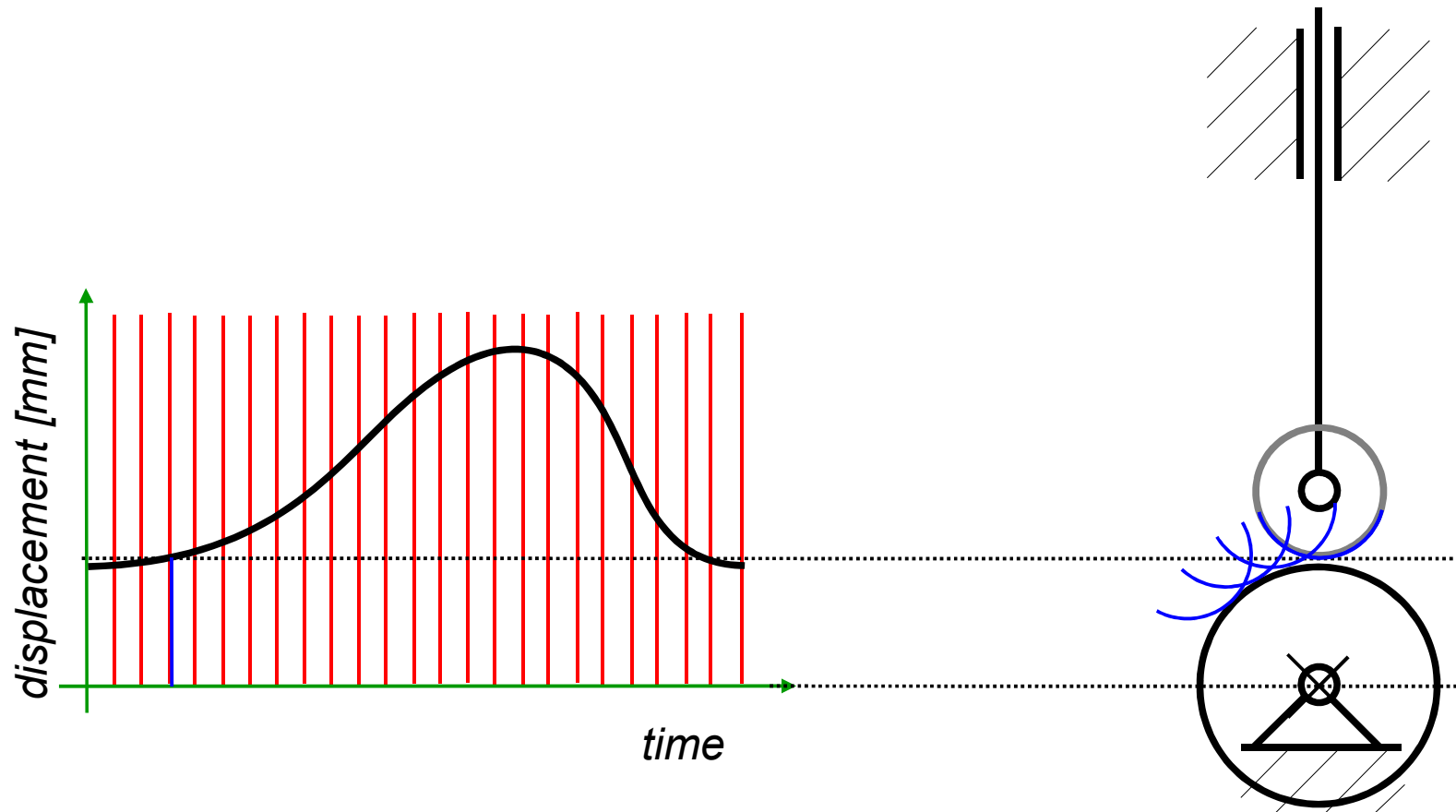

Synthesis of cam-follower mechanisms

Graphical method

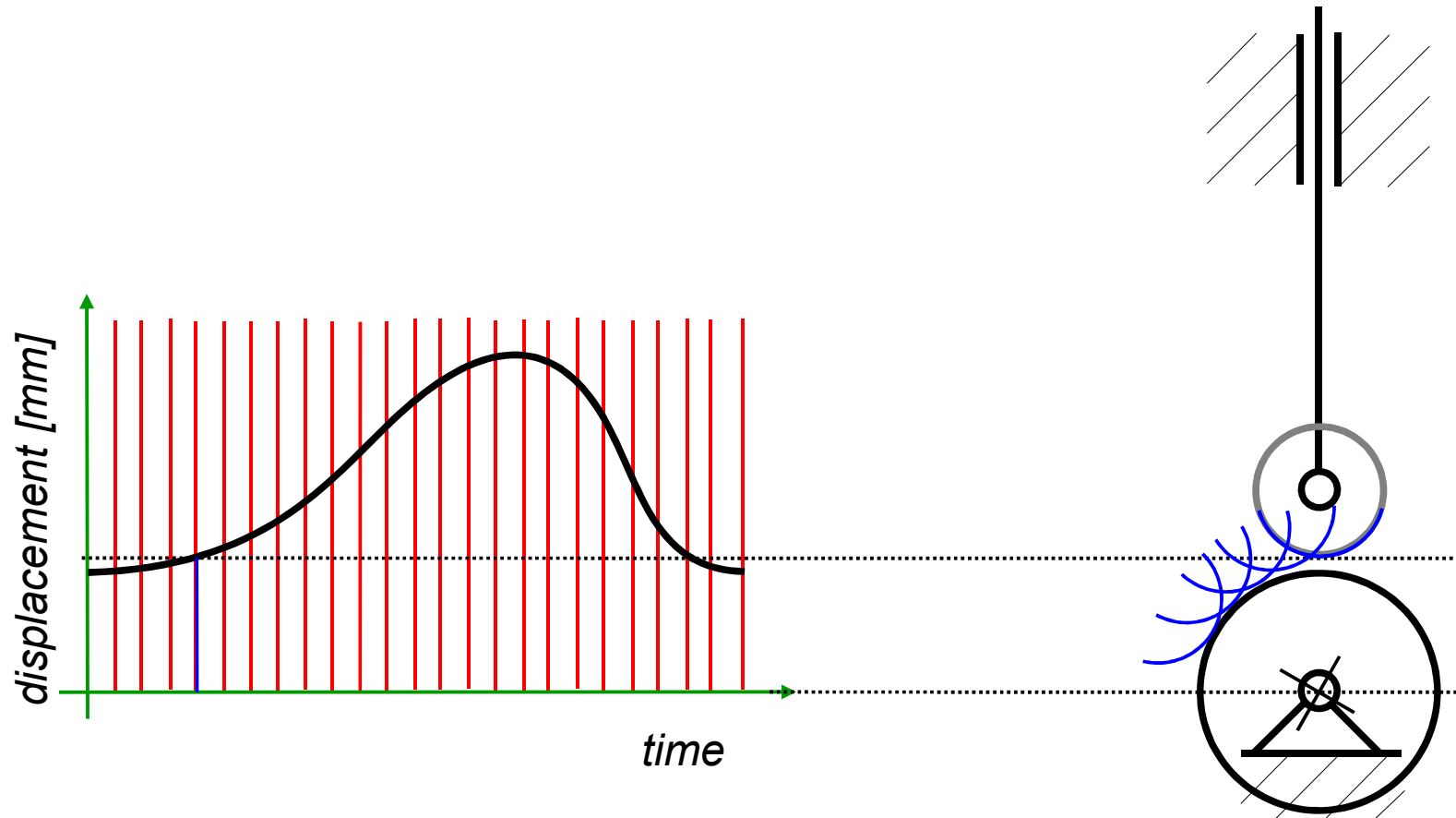

Synthesis of cam-follower mechanisms

Graphical method

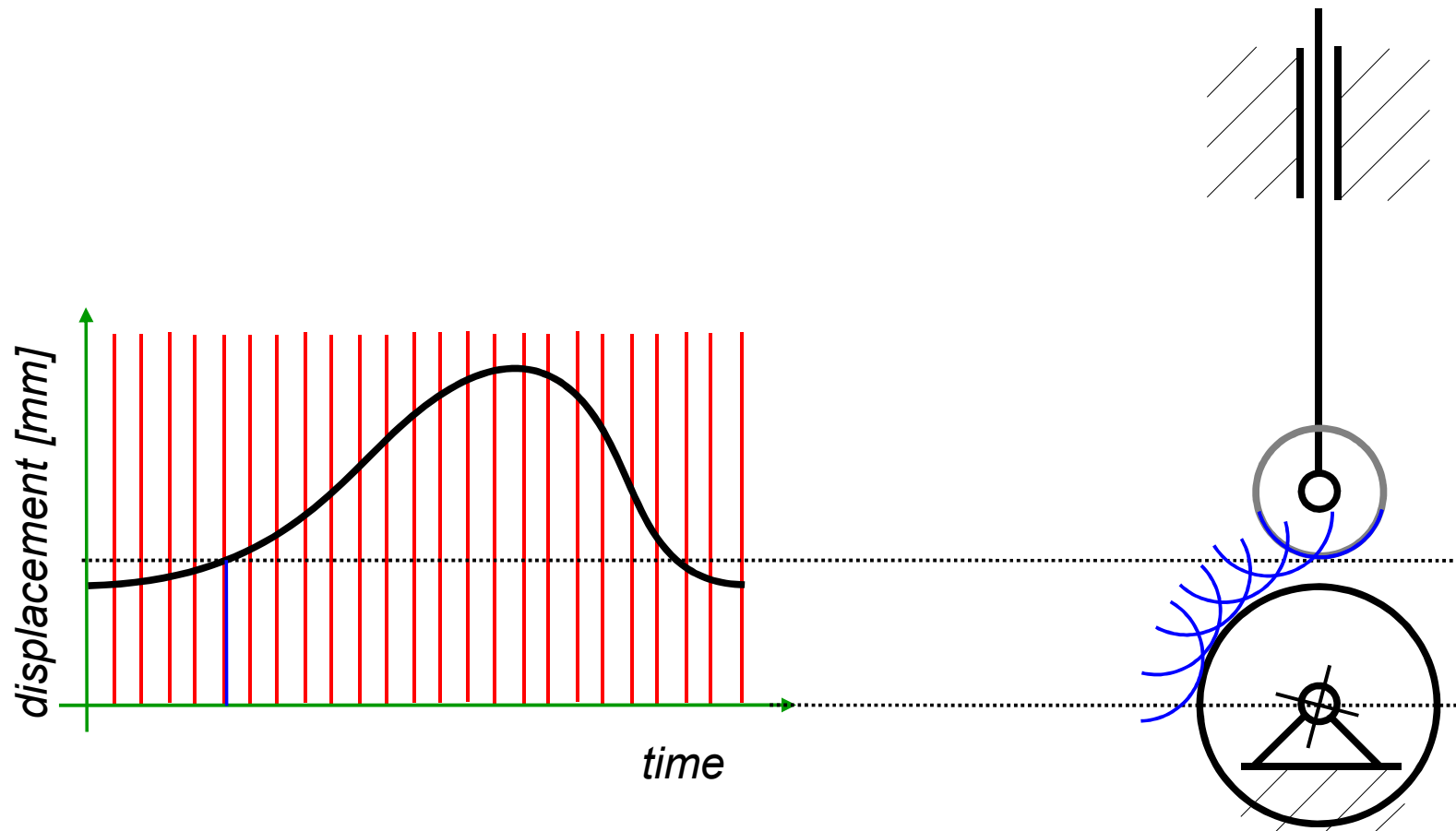

Synthesis of cam-follower mechanisms

Graphical method

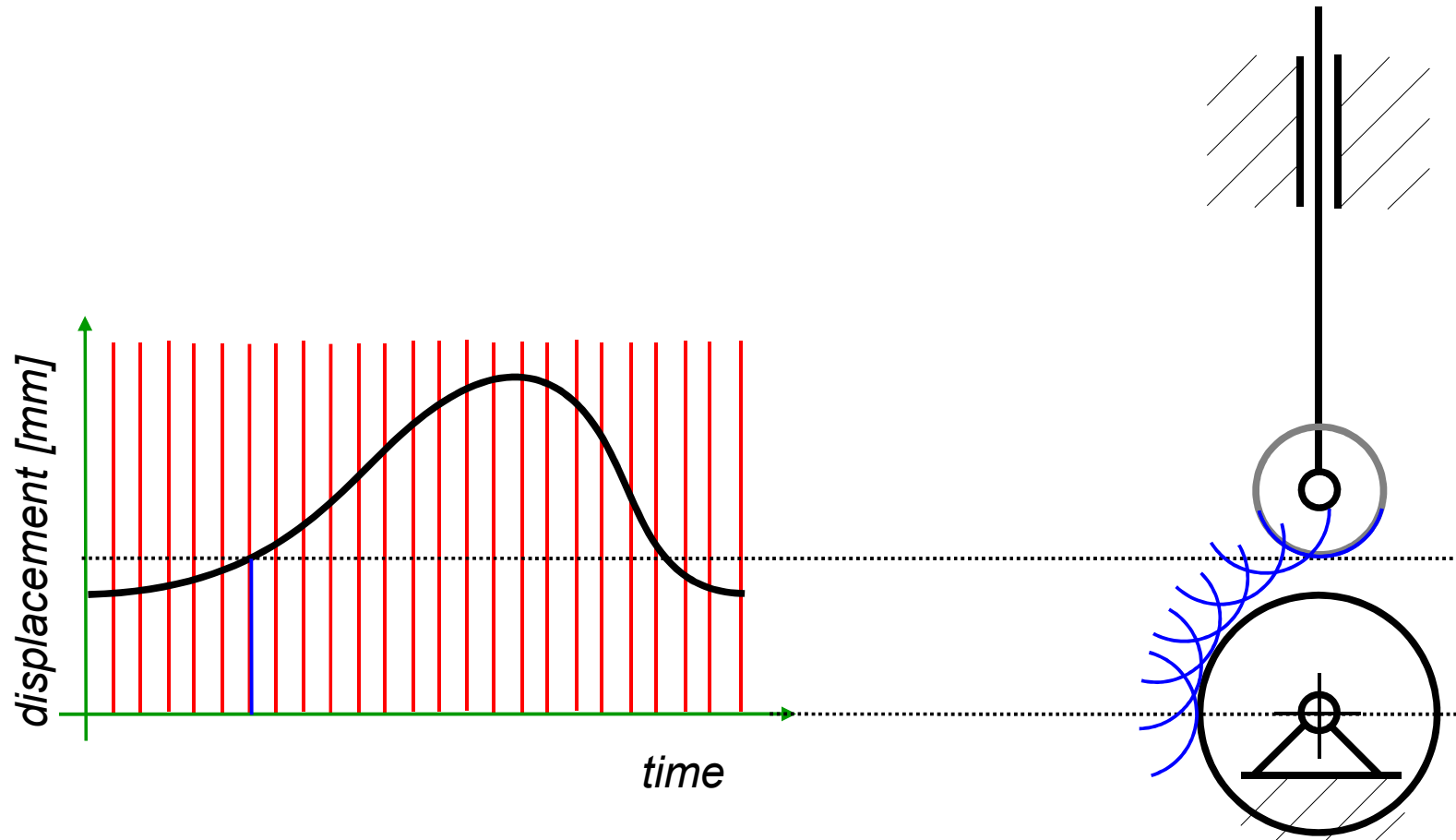

Synthesis of cam-follower mechanisms

Graphical method

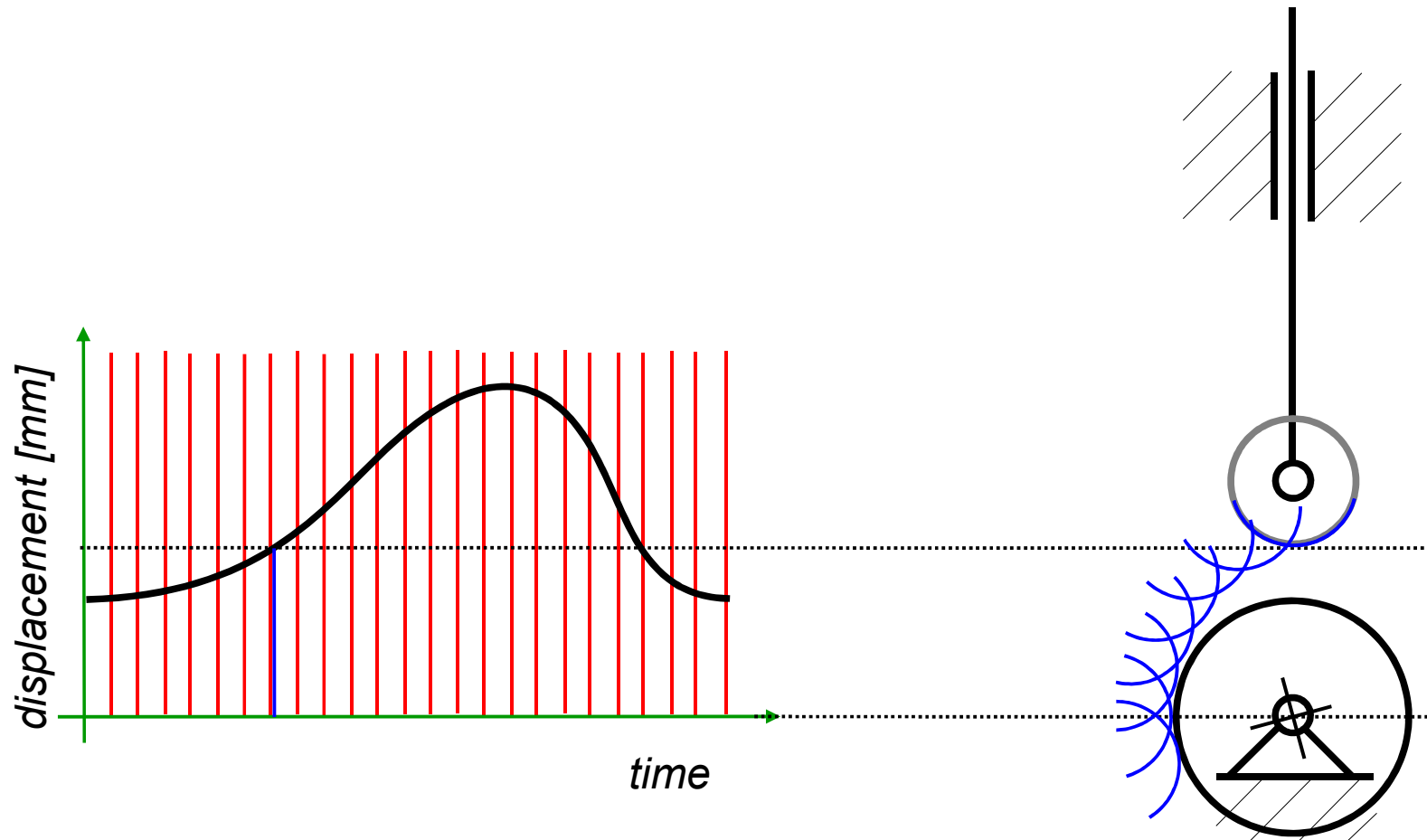

Synthesis of cam-follower mechanisms

Graphical method

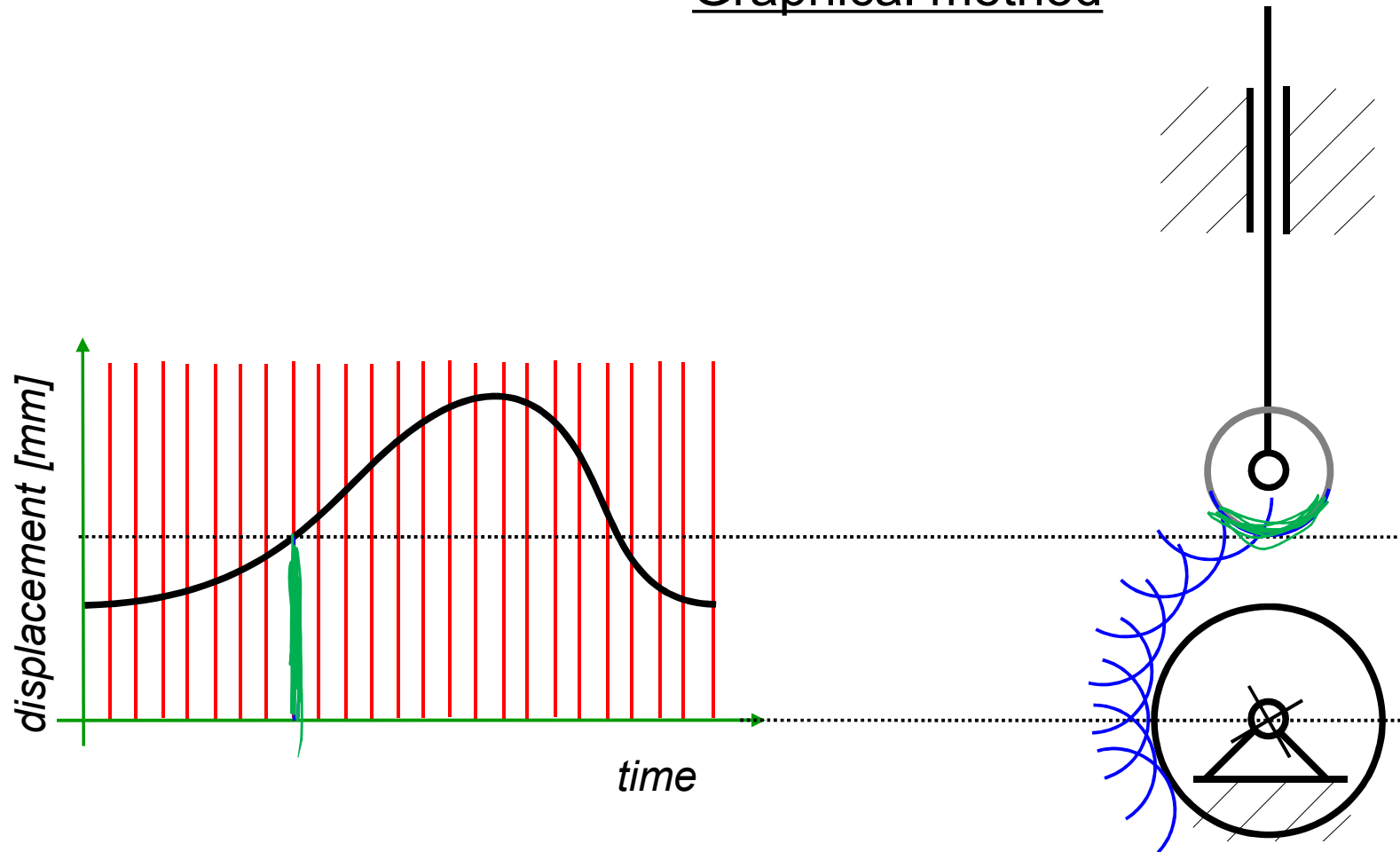

Synthesis of cam-follower mechanisms

Graphical method

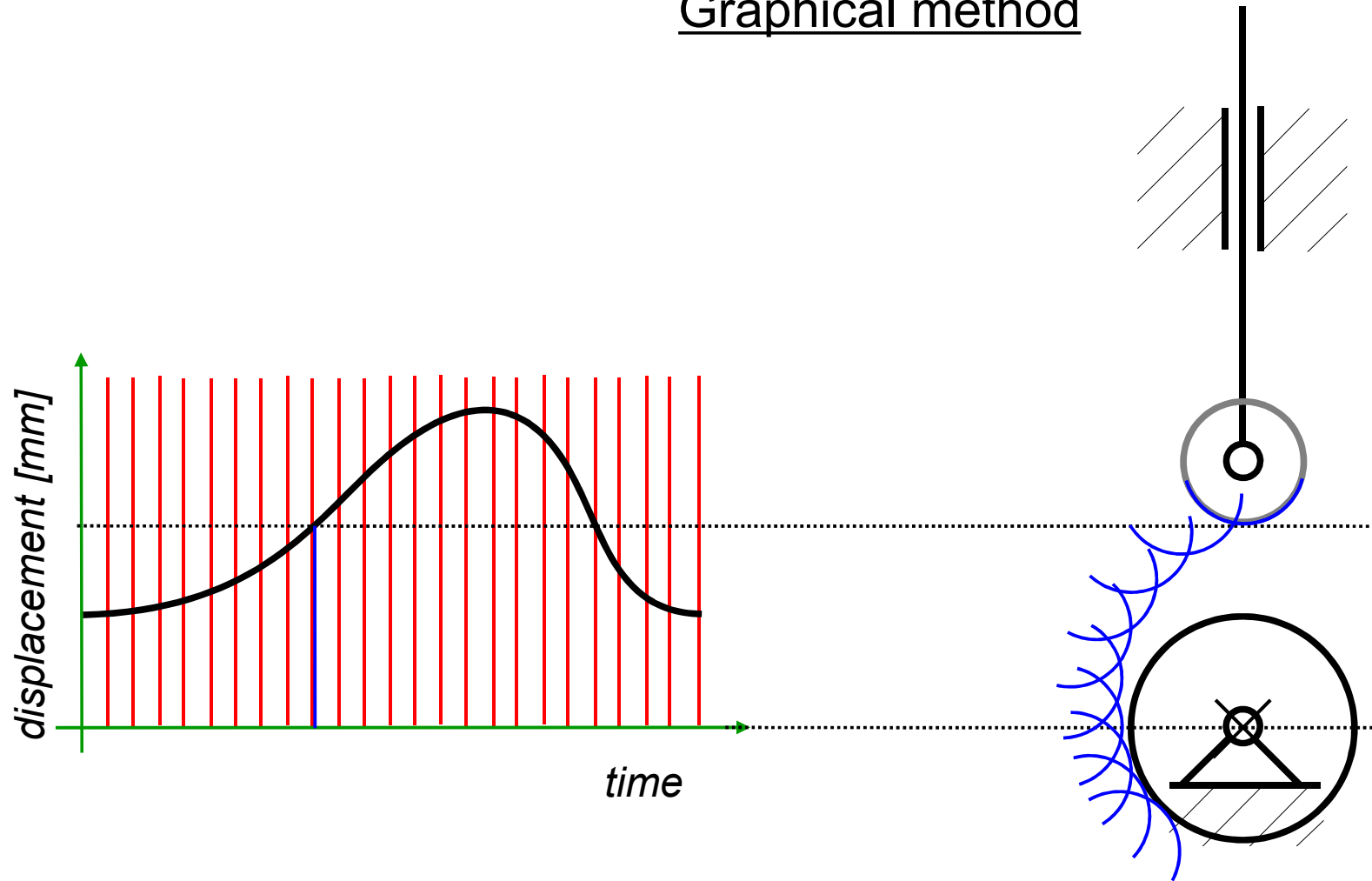

Synthesis of cam-follower mechanisms

Graphical method

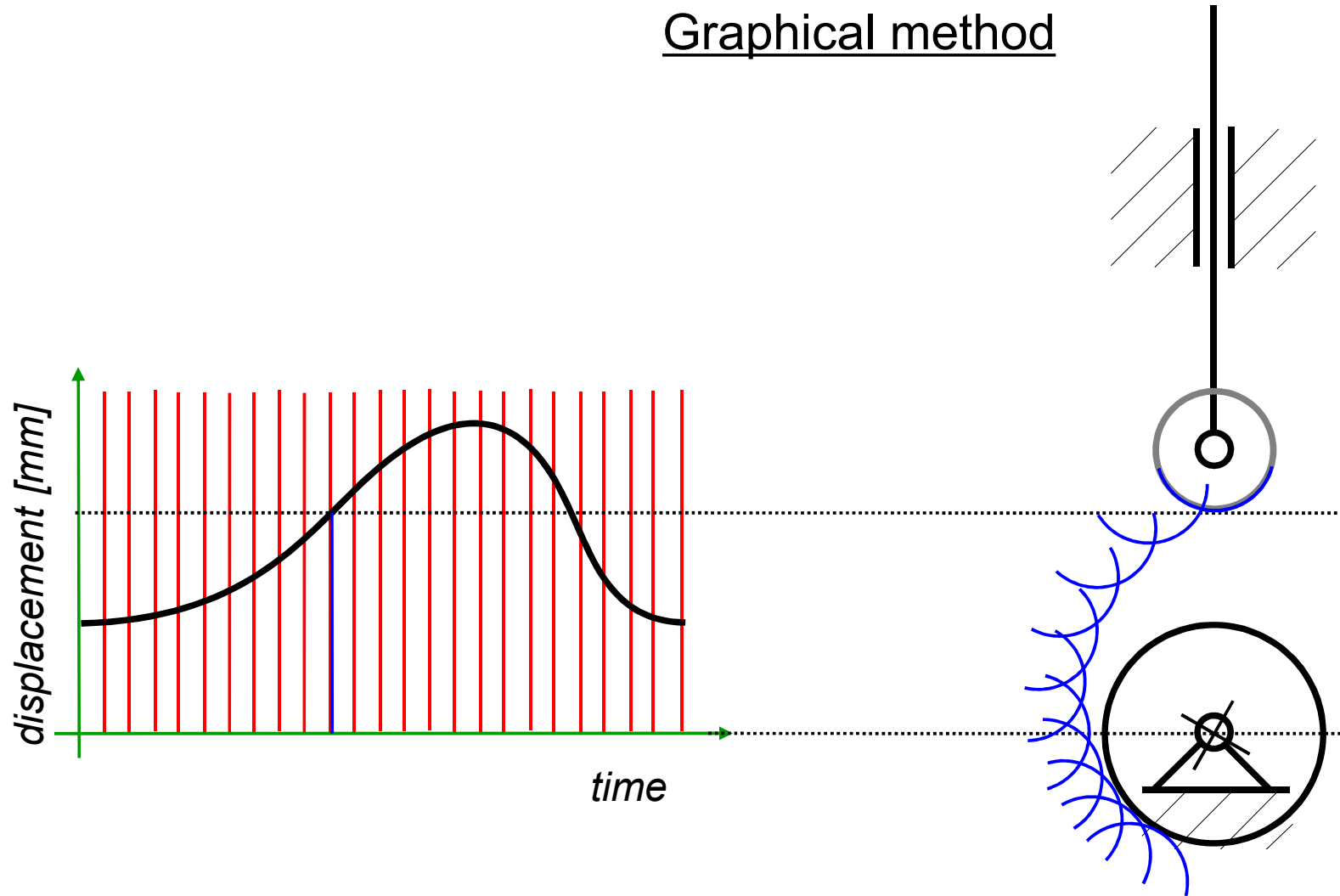

Synthesis of cam-follower mechanisms

Graphical method

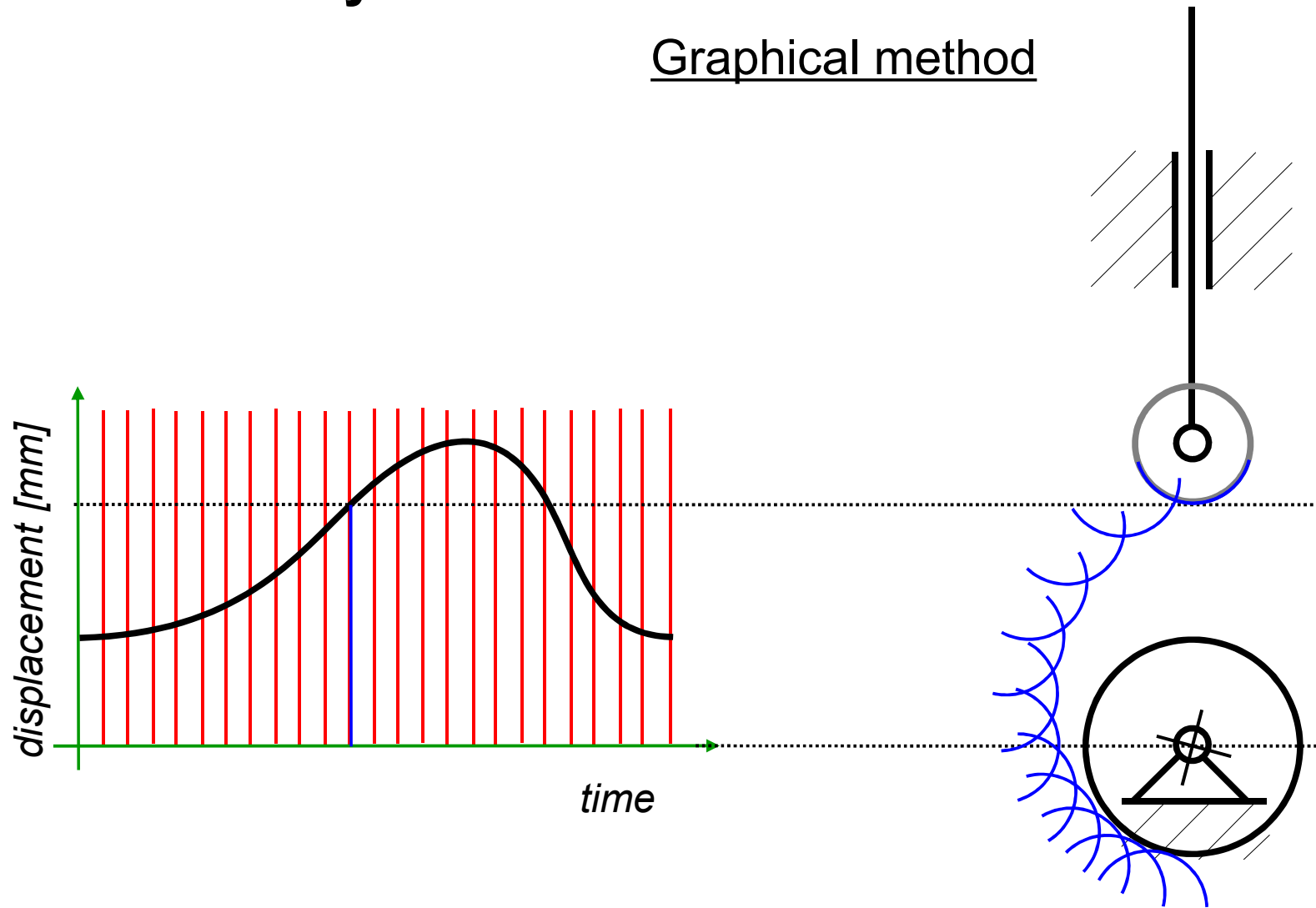

Synthesis of cam-follower mechanisms

Graphical method

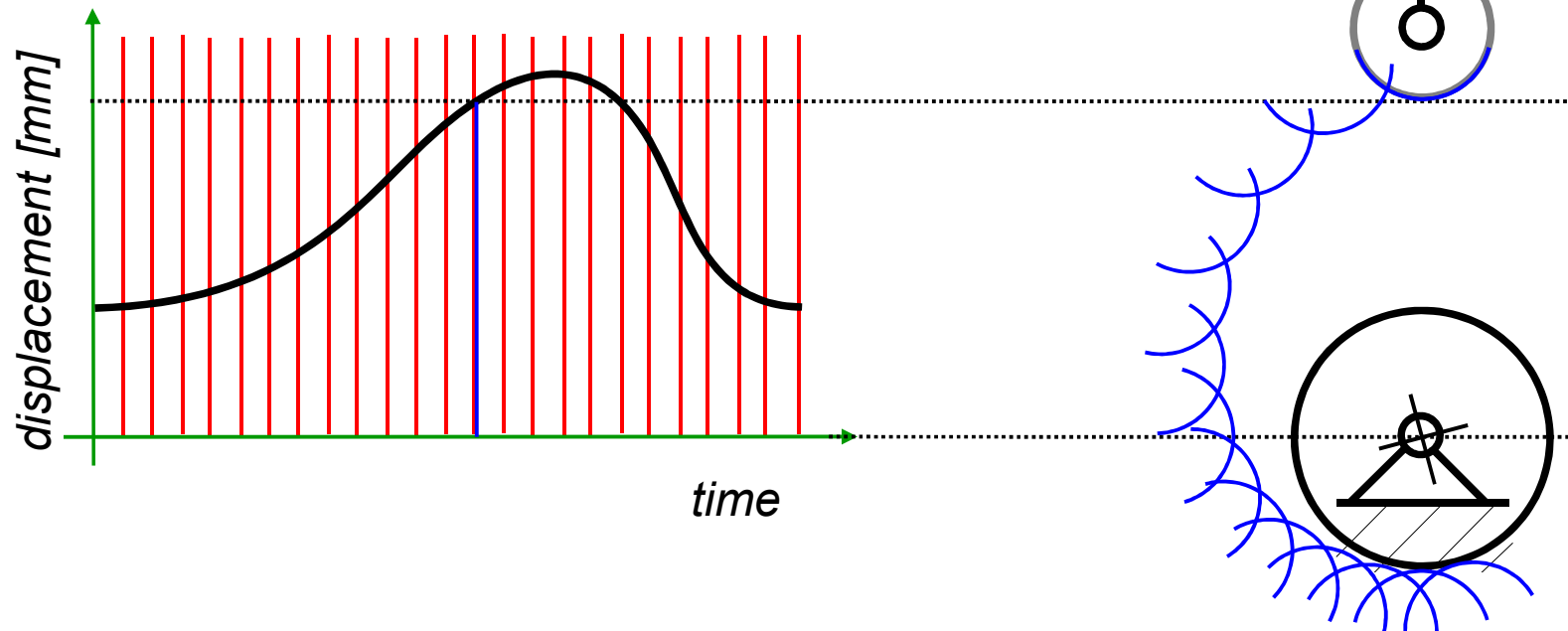

Synthesis of cam-follower mechanisms

Graphical method

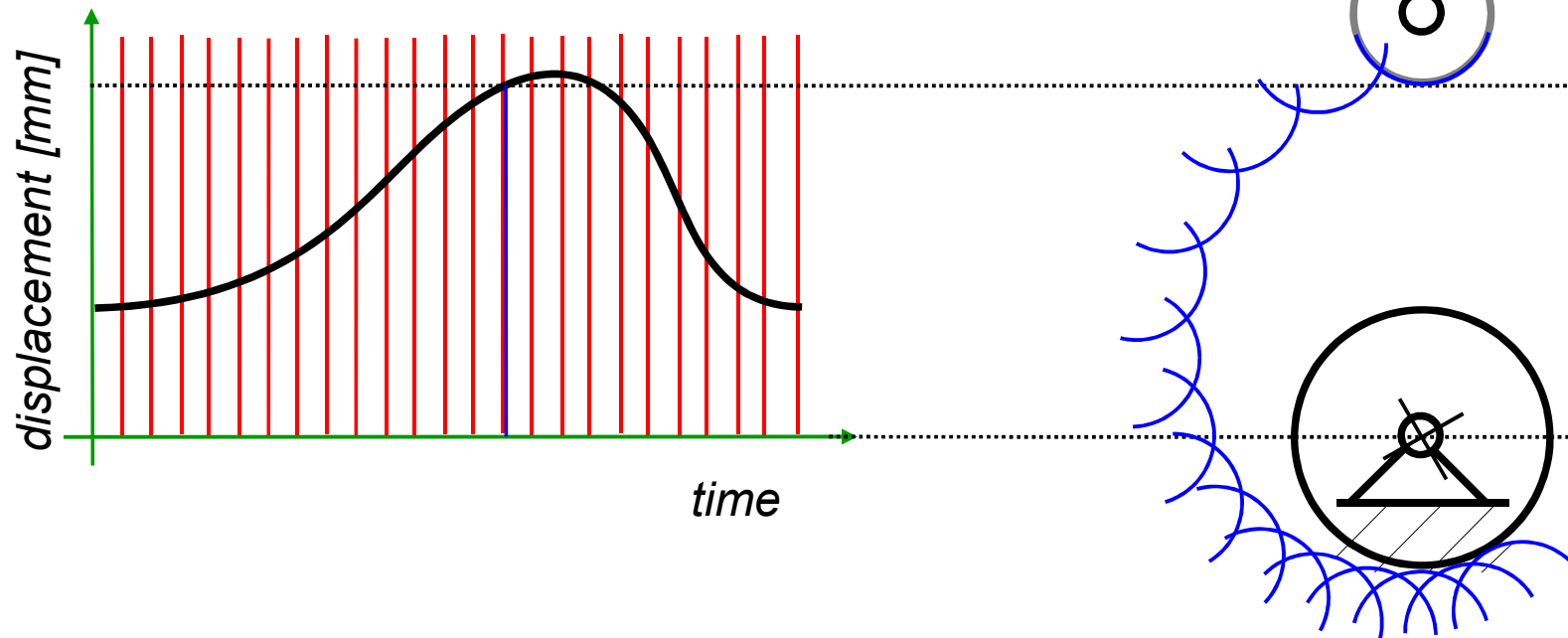

Synthesis of cam-follower mechanisms

Graphical method

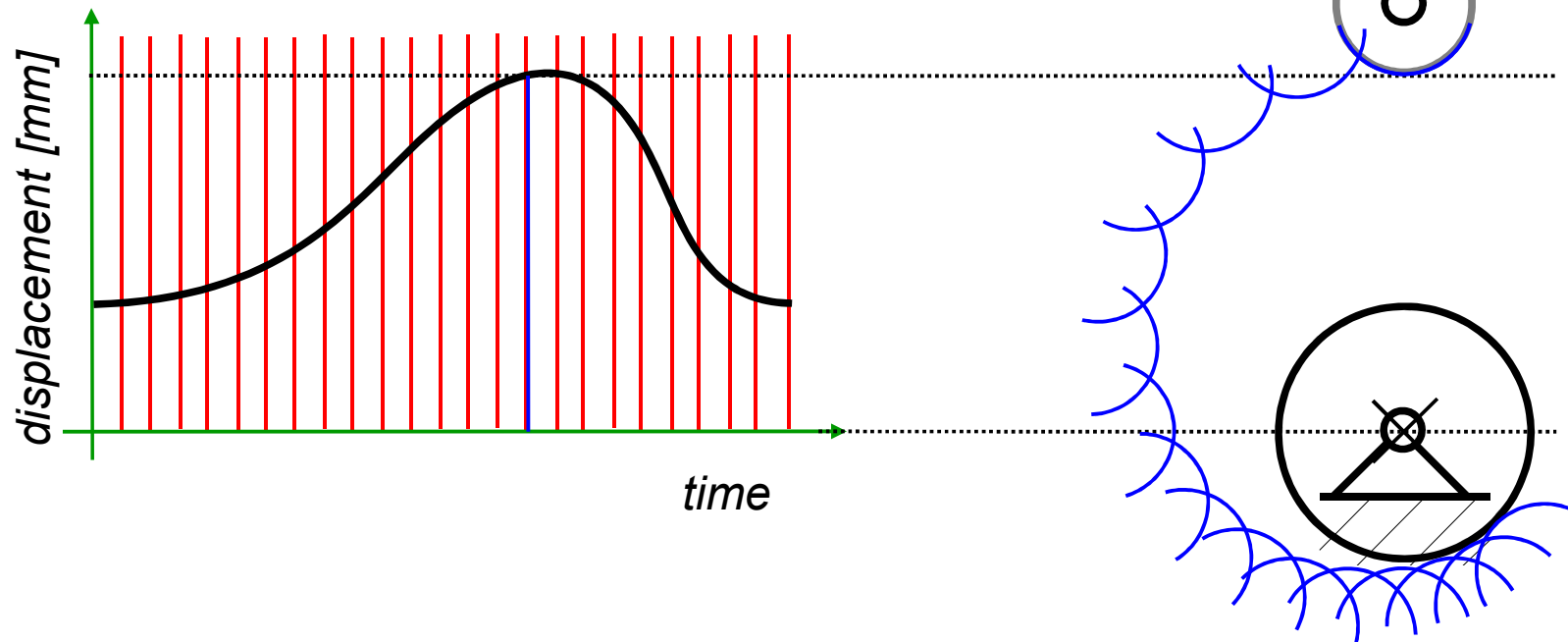

Synthesis of cam-follower mechanisms

Graphical method

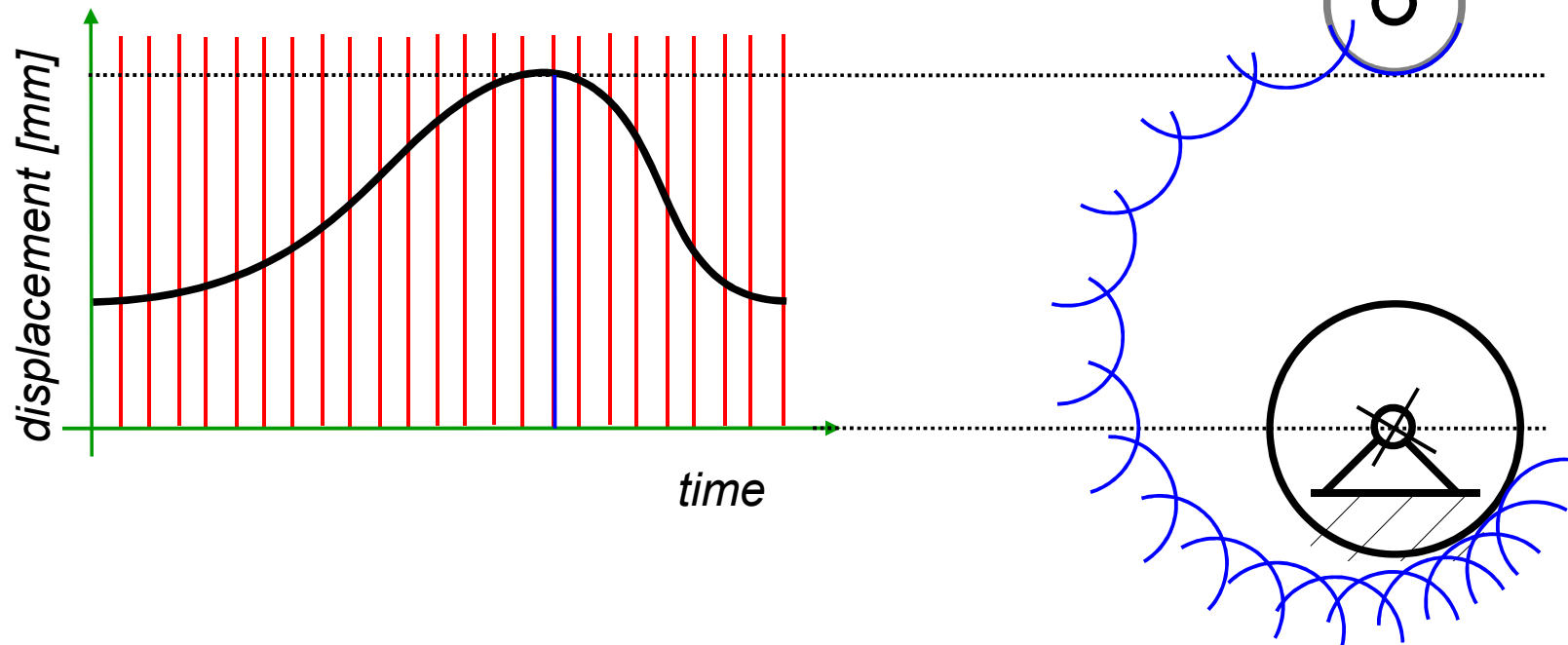

Synthesis of cam-follower mechanisms

Graphical method

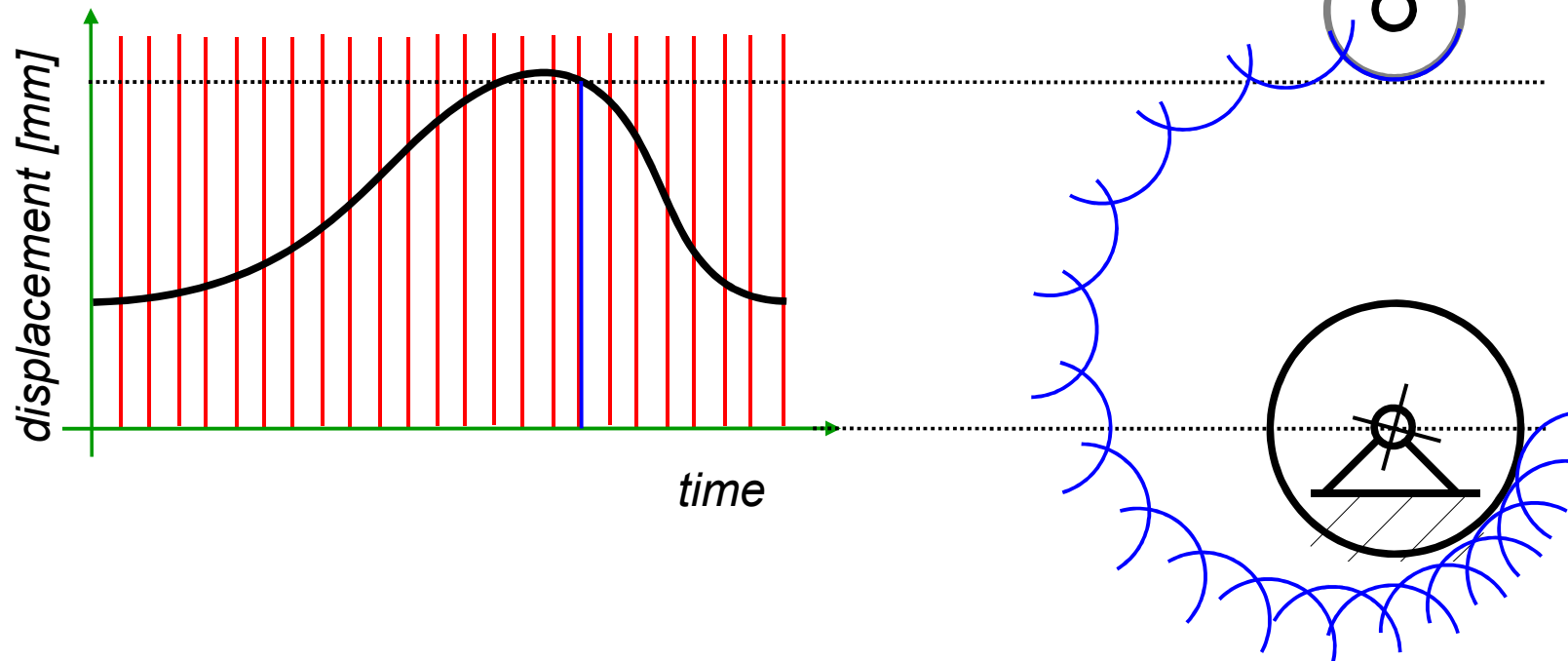

Synthesis of cam-follower mechanisms

Graphical method

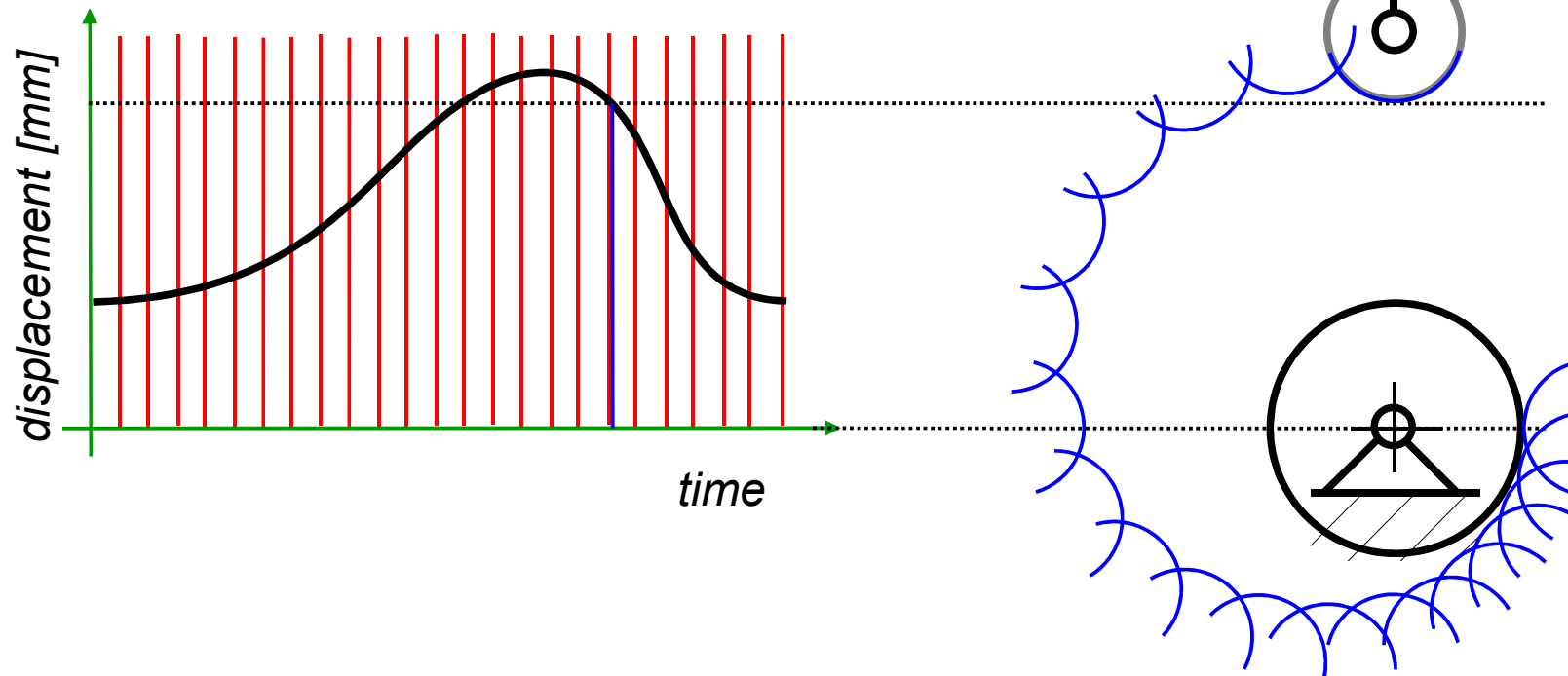

Synthesis of cam-follower mechanisms

Graphical method

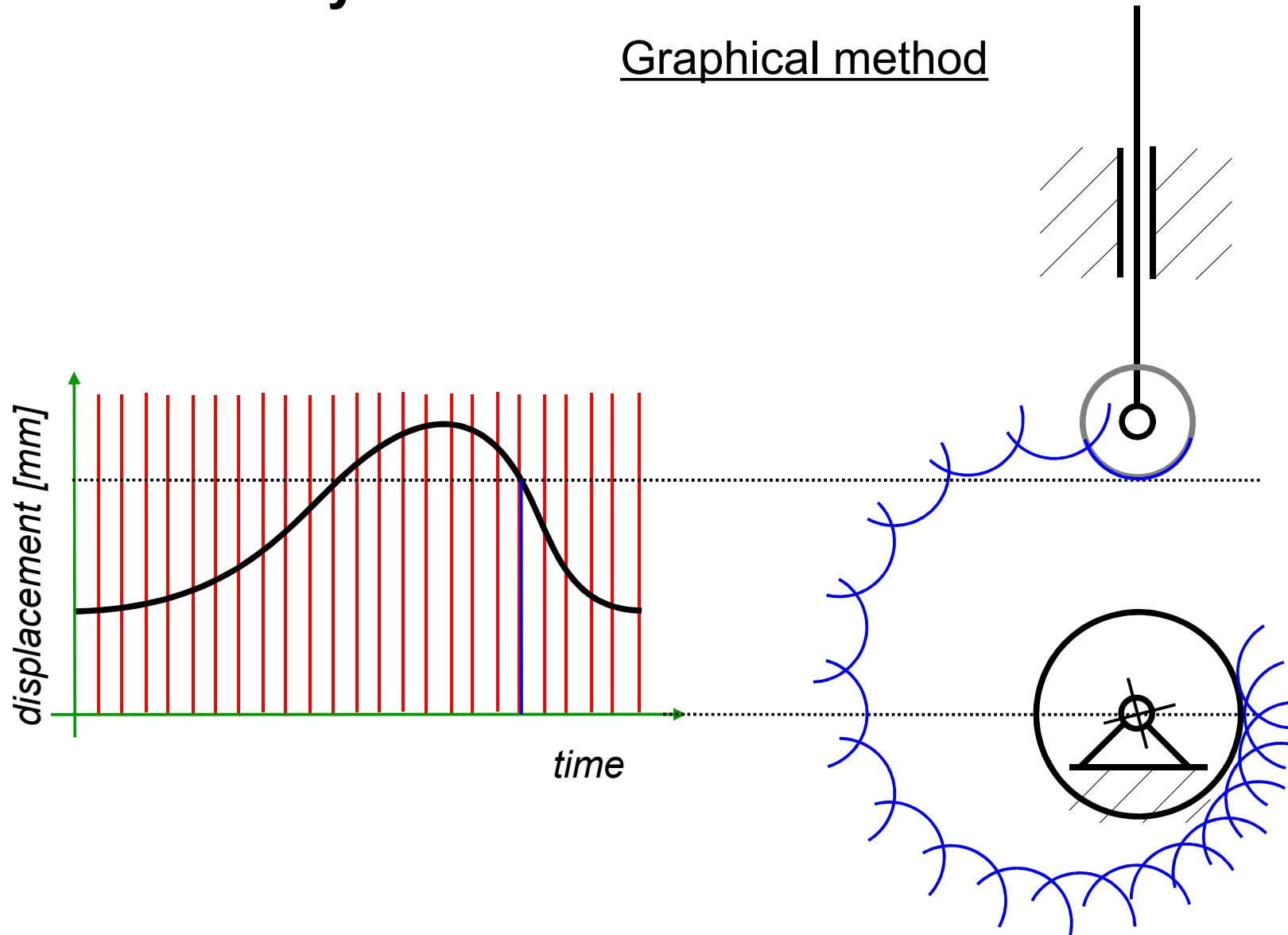

Synthesis of cam-follower mechanisms

Graphical method

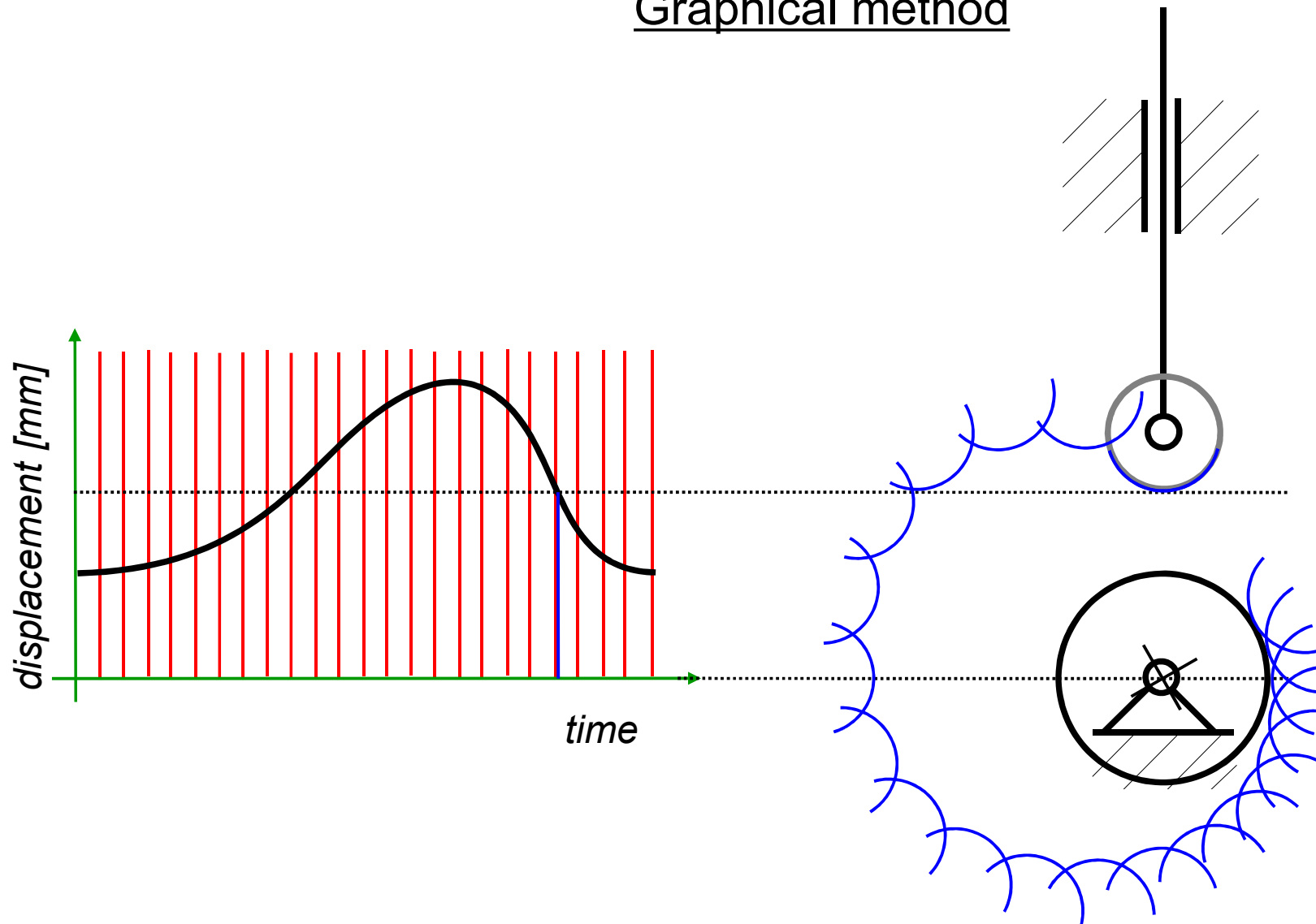

Synthesis of cam-follower mechanisms

Graphical method

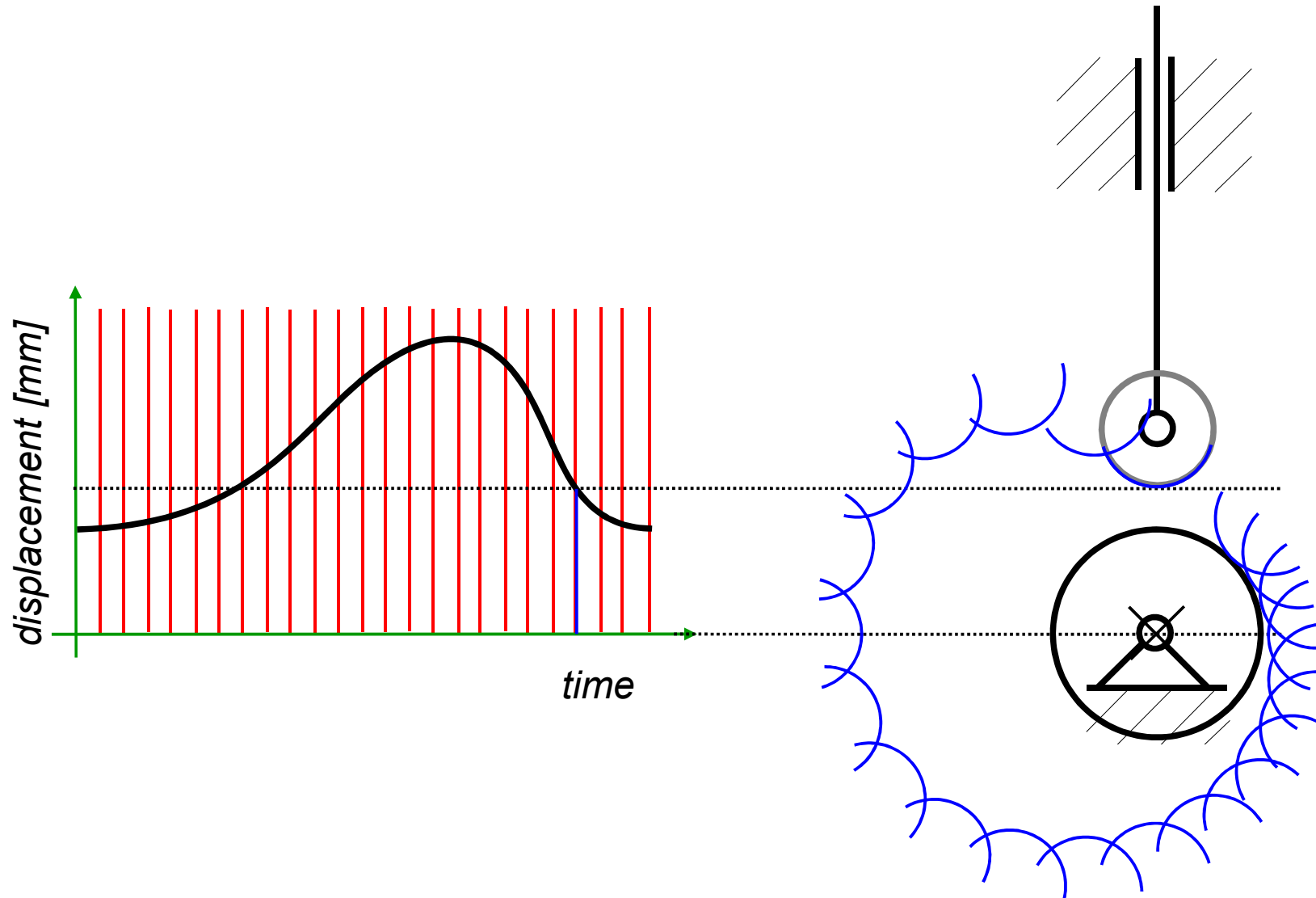

Synthesis of cam-follower mechanisms

Graphical method

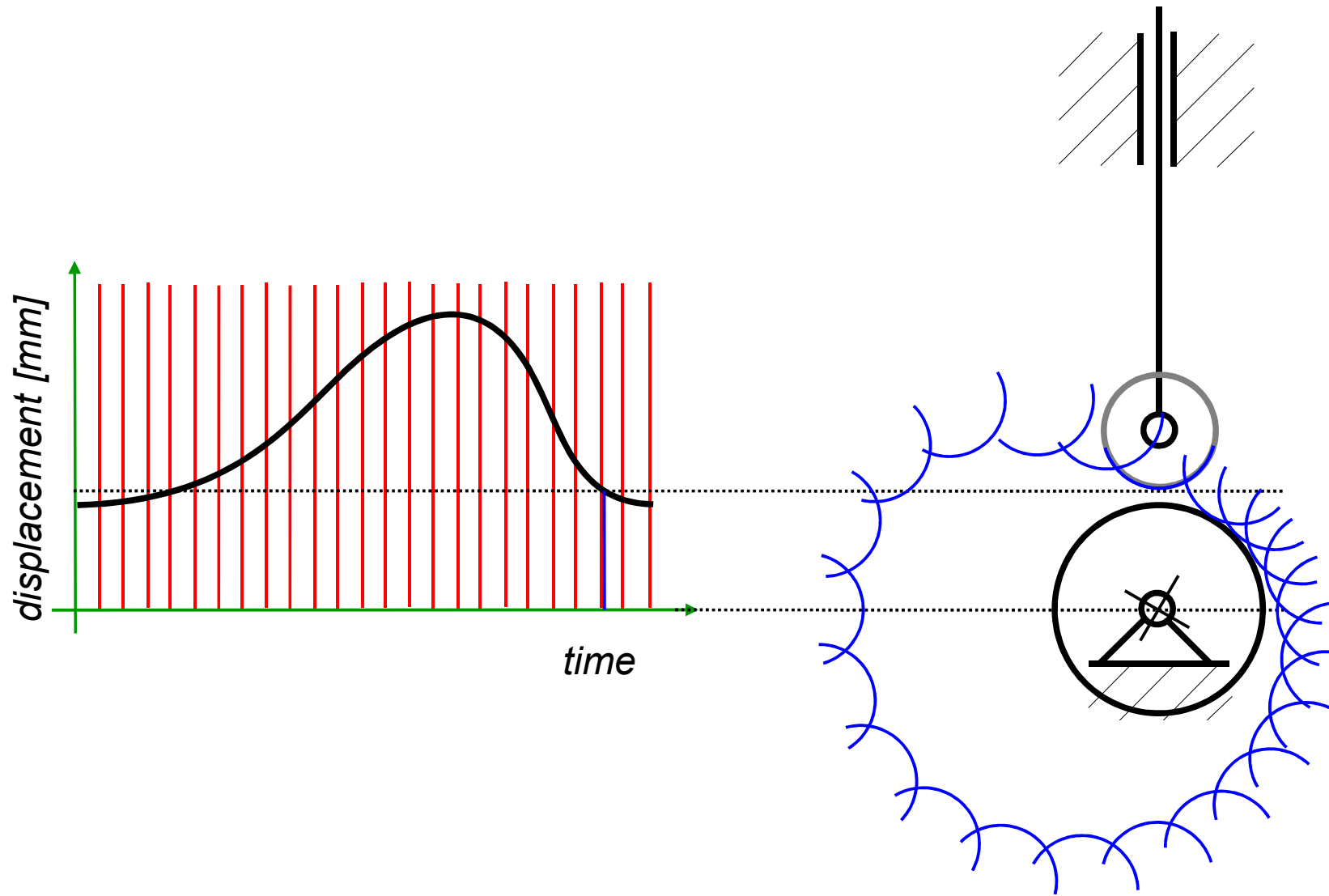

Synthesis of cam-follower mechanisms

Graphical method

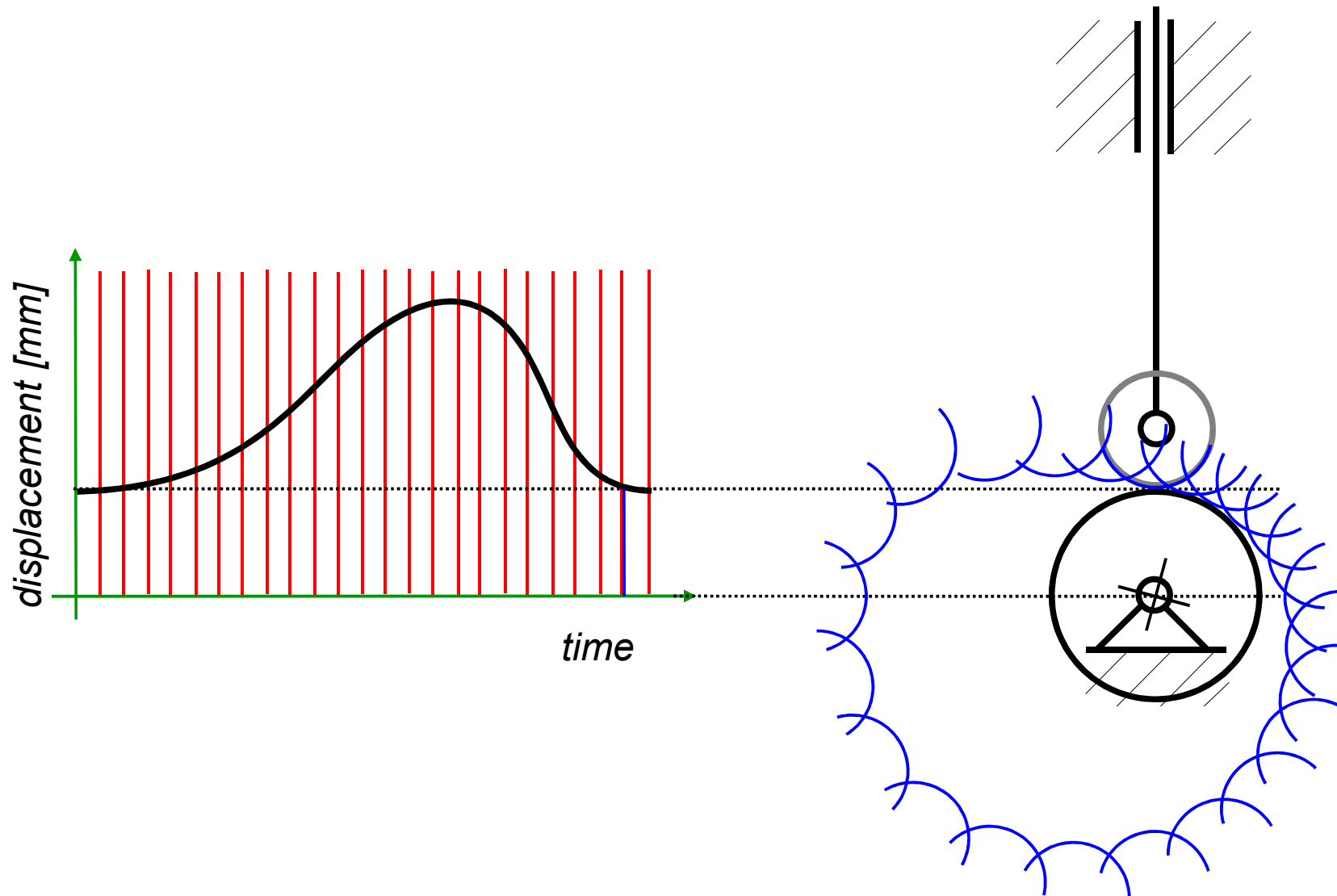

Synthesis of cam-follower mechanisms

Graphical method

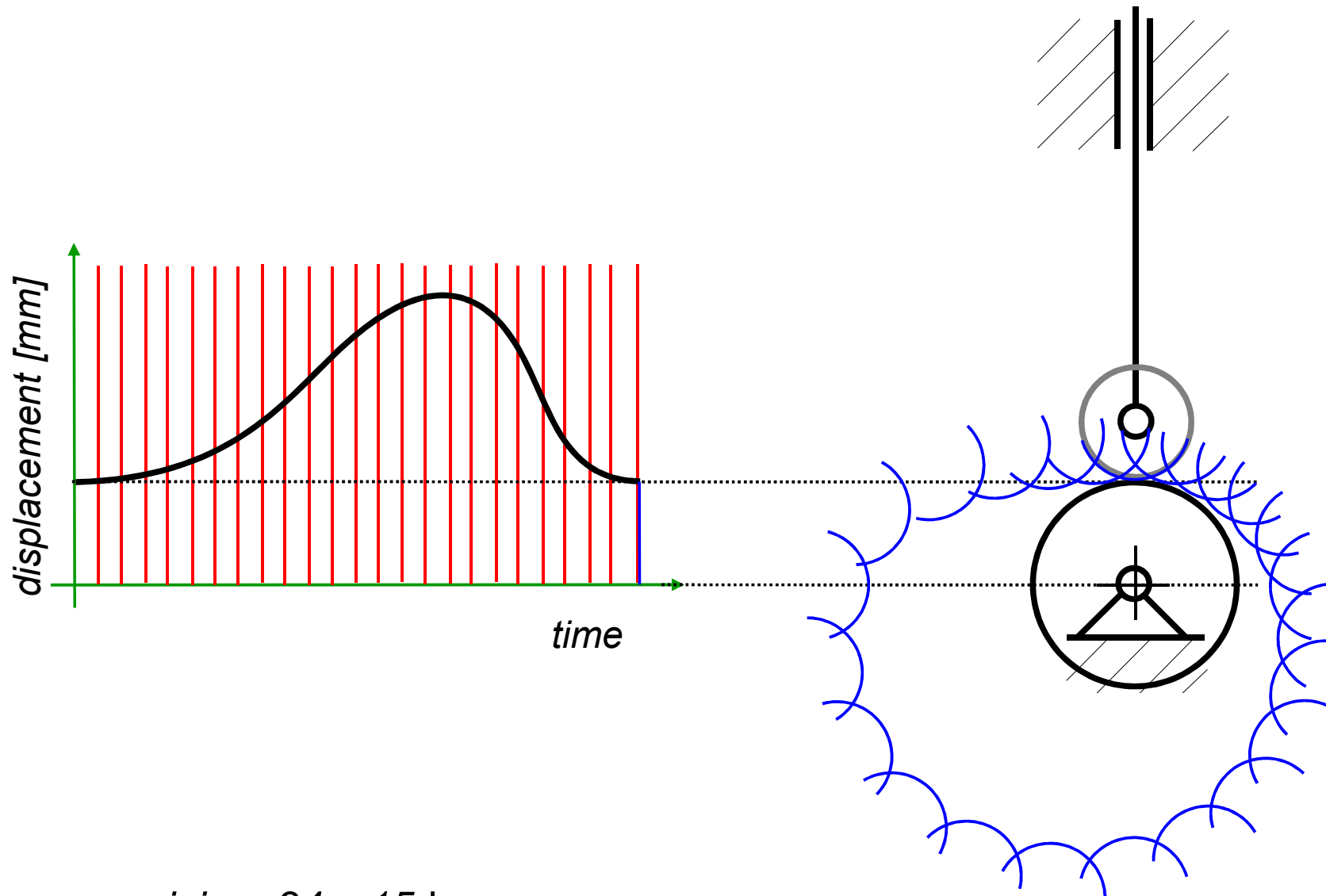

precision: 24 x 15deg

Synthesis of cam-follower mechanisms

Graphical method

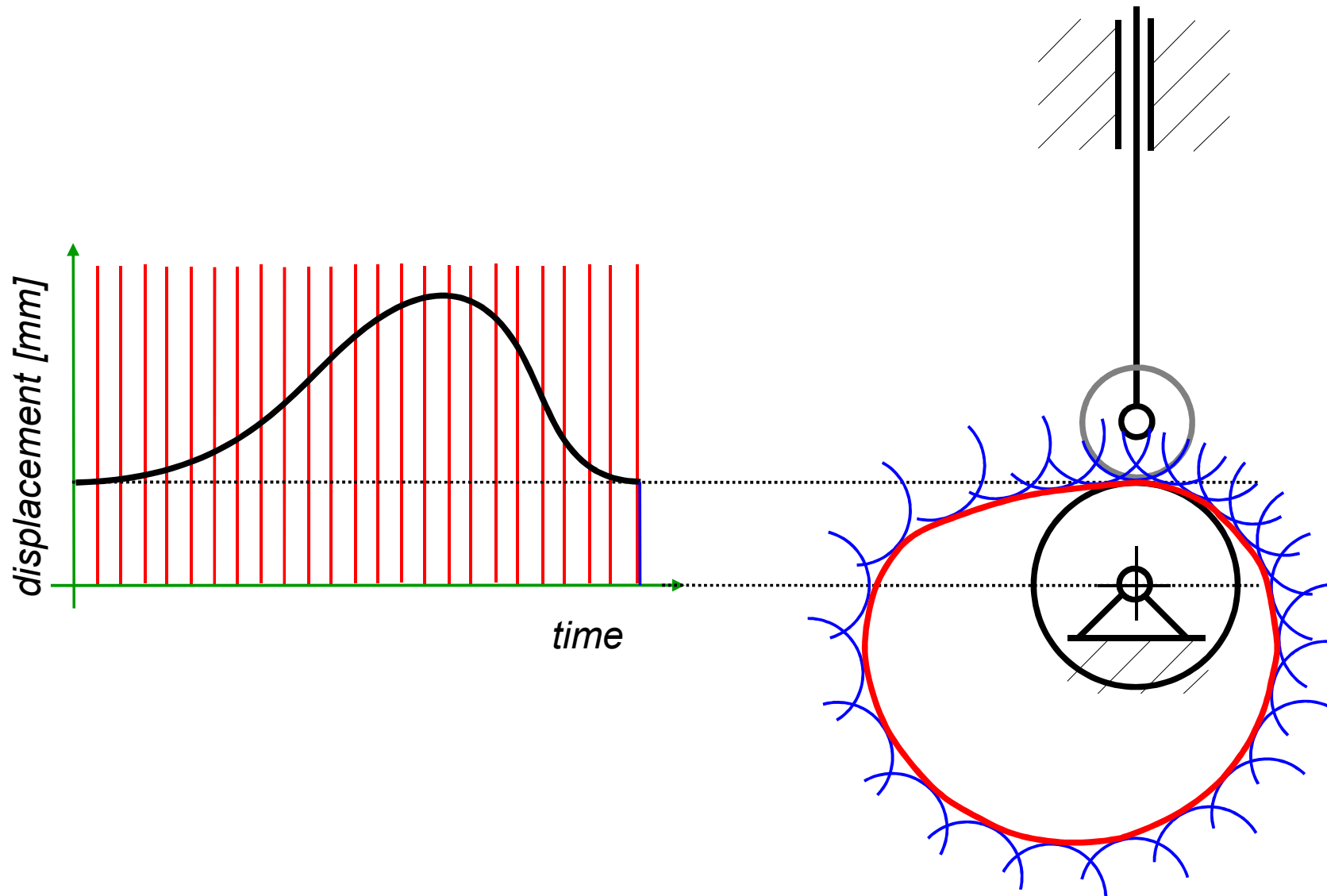

Synthesis of cam-follower mechanisms

Graphical method

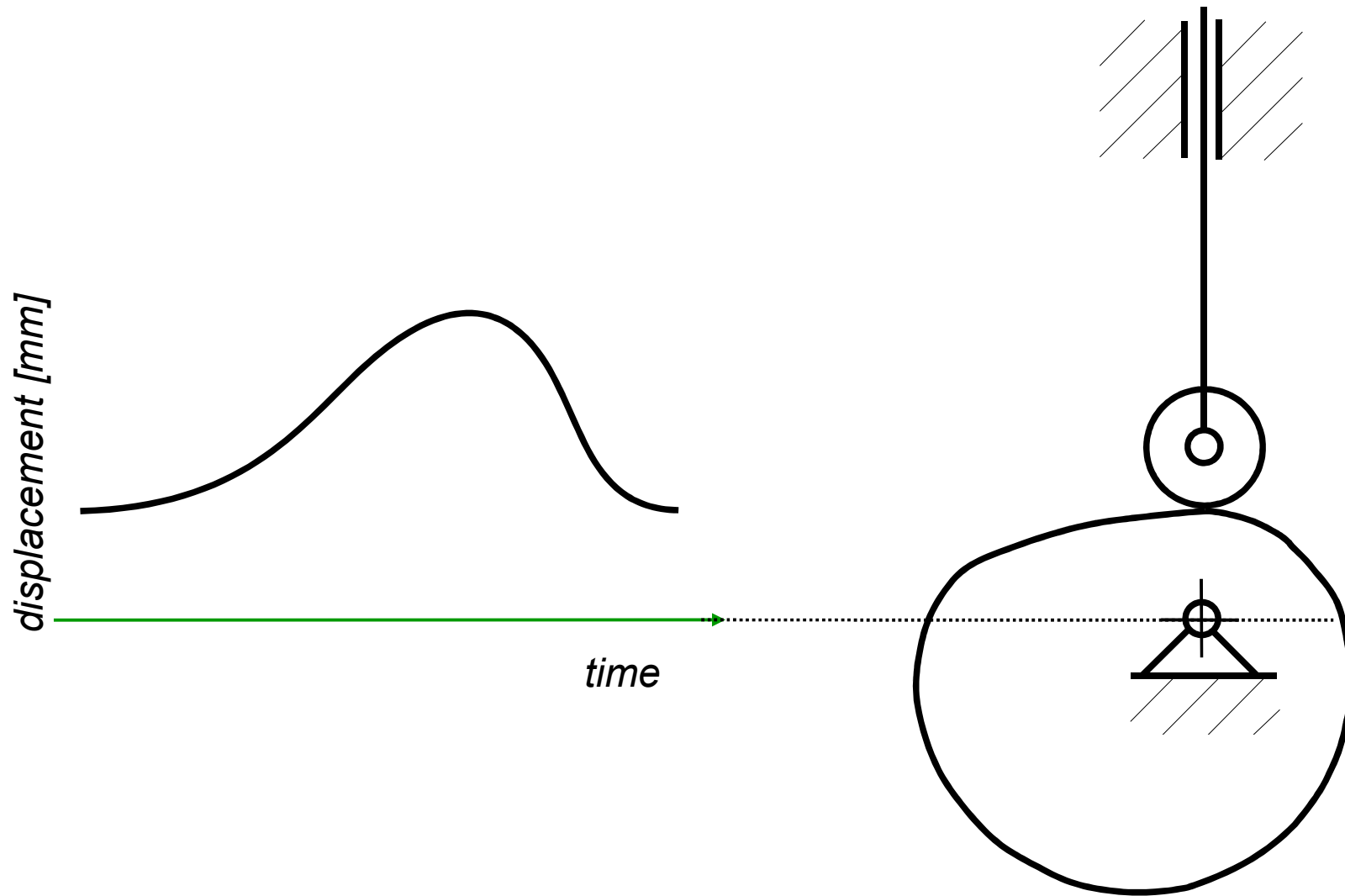

Synthesis of cam-follower mechanisms

Analytical method

Synthesis of cam-follower mechanisms

Analytical method

For a given function of velocity or acceleration, function of a follower displacement can be found by integration.

Follower displacement as a function of cam angle could be used to obtain cam outline directly (or after change of coordinates).

For a knife-edge follower we will obtain exact real displacement.

For a roller-ended follower some errors are possible.

Roller-ended follower give us limitation of a maximum velocity (there is a relation between roller radius and cam size).

Usually we are designing symmetric and smooth cams.

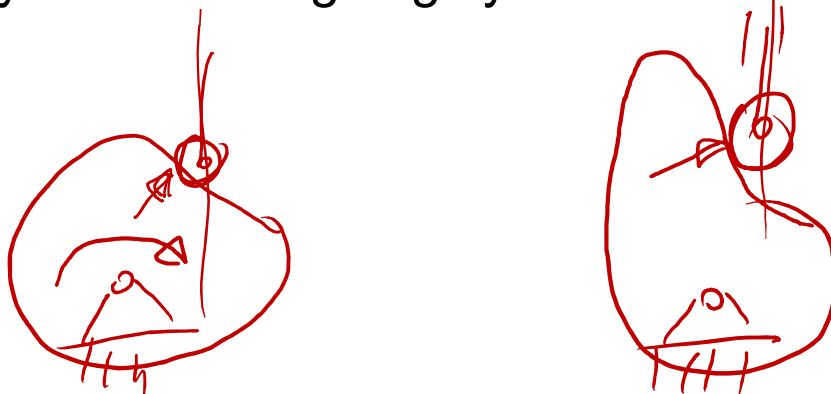

Synthesis of cam-follower mechanisms

Analytical method – example

Design profile of a cam cooperating with eccentric knife-edge follower to obtain constant acceleration of uplift and downlift with constant angular velocity.

Synthesis of cam-follower mechanisms

Analytical method – example

Design profile of a cam cooperating with eccentric knife-edge follower to obtain constant acceleration of uplift and downlift with constant angular velocity.

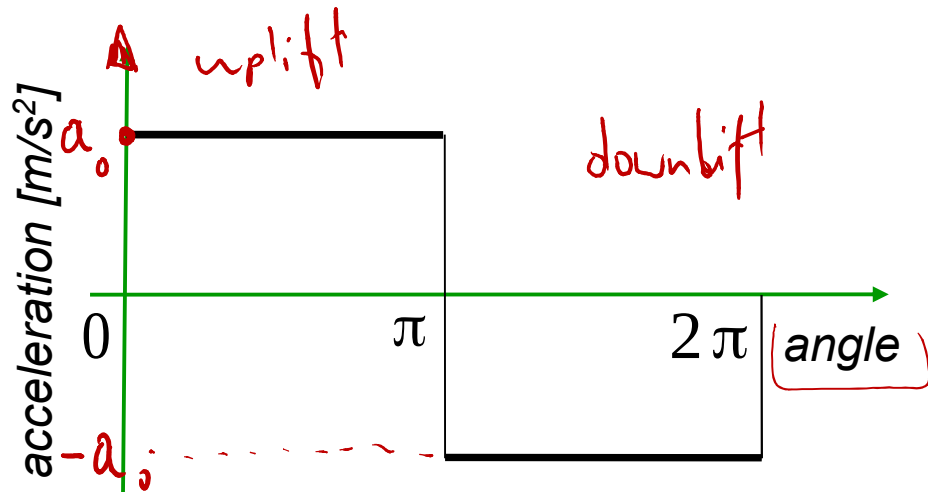

Synthesis of cam-follower mechanisms

Analytical method – example

Design profile of a cam cooperating with eccentric knife-edge follower to obtain constant acceleration of uplift and downlift with constant angular velocity.

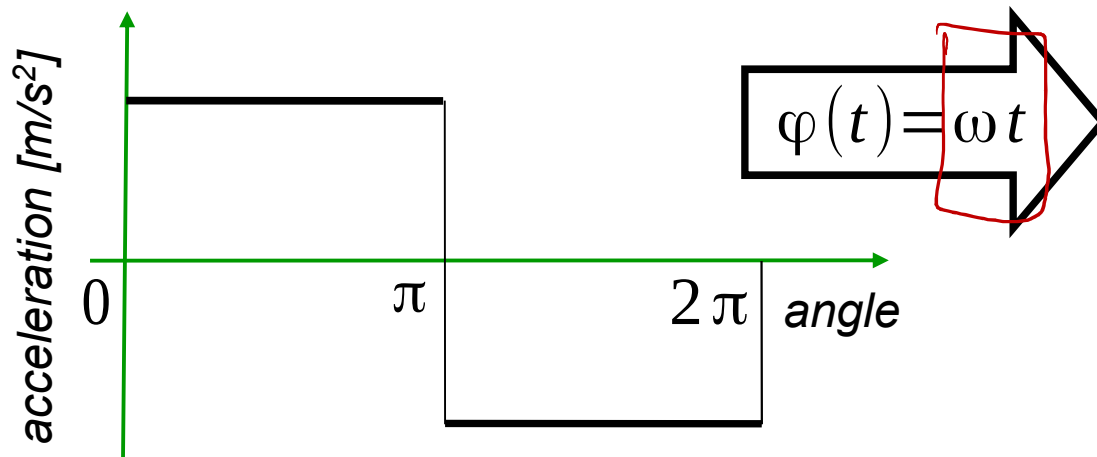

Synthesis of cam-follower mechanisms

Analytical method – example

Design profile of a cam cooperating with eccentric knife-edge follower to obtain constant acceleration of uplift and downlift with constant angular velocity.

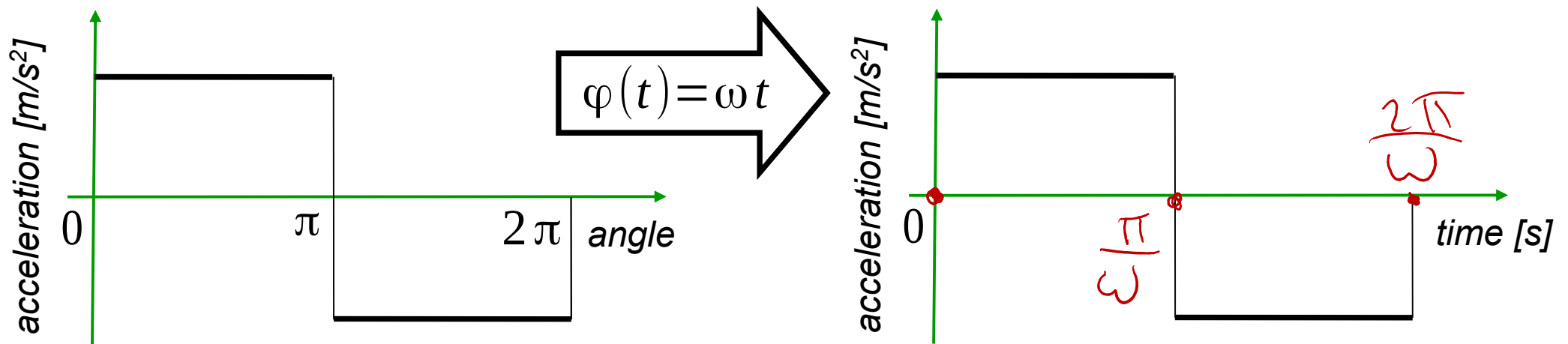

Synthesis of cam-follower mechanisms

Analytical method – example

Design profile of a cam cooperating with eccentric knife-edge follower to obtain constant acceleration of uplift and downlift with constant angular velocity.

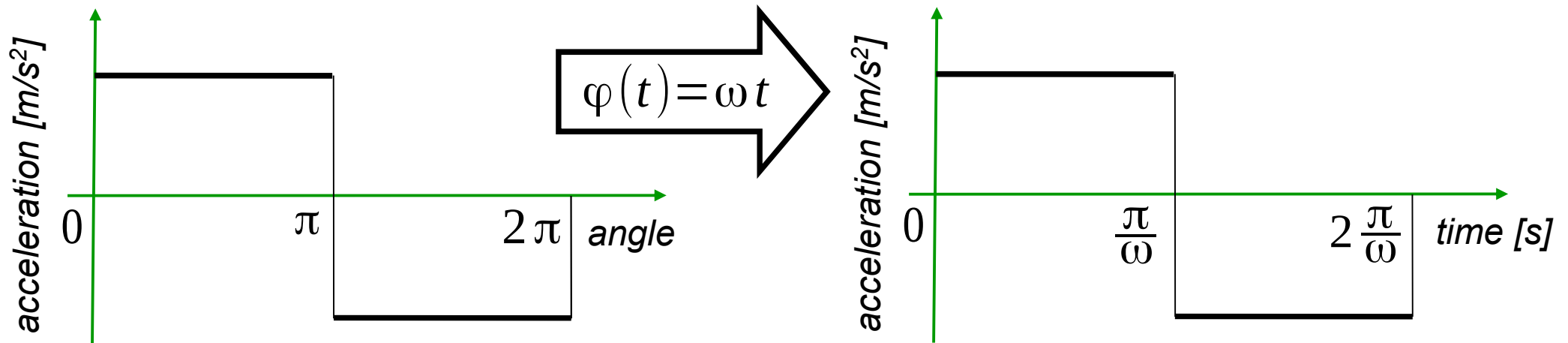

Synthesis of cam-follower mechanisms

Analytical method – example

Design profile of a cam cooperating with eccentric knife-edge follower to obtain constant acceleration of uplift and downlift with constant angular velocity.

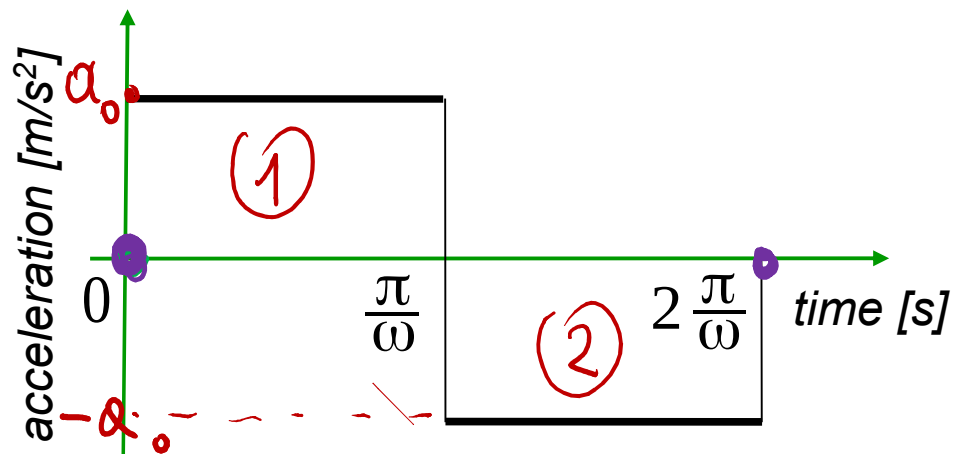

$$\textcircled{1} a_1(t) = a_0$$

$$v_1(t) = \int a_1(t) dt = a_0 t + C_1$$

$$h_1(t) = \int v_1(t) dt = \frac{a_0 t^2}{2} + C_1 t + C_2$$

$$R = 0 + 0 + C_2$$

$$\textcircled{2} a_2(t) = -a_0$$

$$v_2(t) = -a_0 t + C_3$$

$$h_2(t) = -a_0 \frac{t^2}{2} + C_3 t + C_4$$

minimum

Smooth shape!

$$h_1(t=0) = h_2(t=\frac{2\pi}{\omega}) = R$$

$$C_2 = R$$

$$R = -a_0 \frac{4\pi^2}{2\omega^2} + C_3 \frac{2\pi}{\omega} + C_4$$

$$C_4 = R + a_0 \frac{2\pi^2}{\omega^2} + C_3 \frac{2\pi}{\omega}$$

Synthesis of cam-follower mechanisms

Analytical method – example

Design profile of a cam cooperating with eccentric knife-edge follower to obtain constant acceleration of uplift and downlift with constant angular velocity.

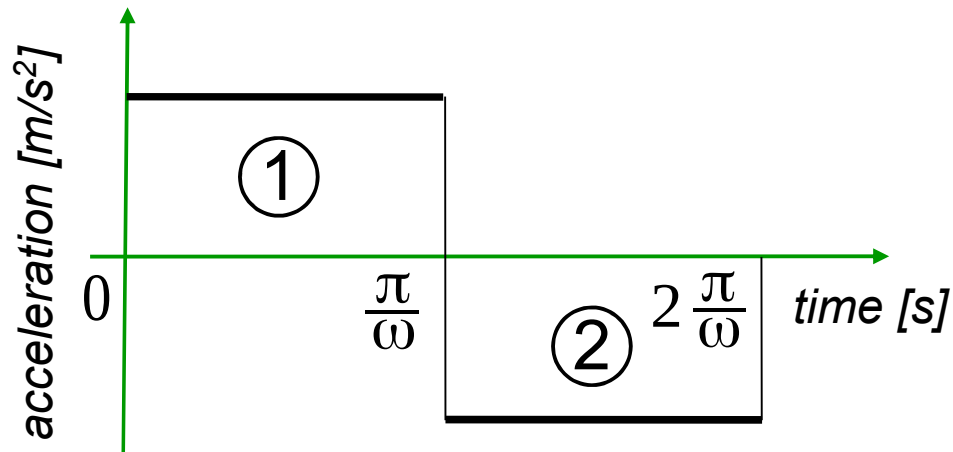

$$a_1 = a_0$$

$$v_1(t) = a_0 t + C_1$$

$$h_1(t) = \frac{a_0 t^2}{2} + C_1 t + C_2$$

$$a_2 = -a_0$$

$$v_2(t) = -a_0 t + C_3$$

$$h_2(t) = \frac{-a_0 t^2}{2} + C_3 t + C_4$$

Synthesis of cam-follower mechanisms

Analytical method – example

Design profile of a cam cooperating with eccentric knife-edge follower to obtain constant acceleration of uplift and downlift with constant angular velocity.

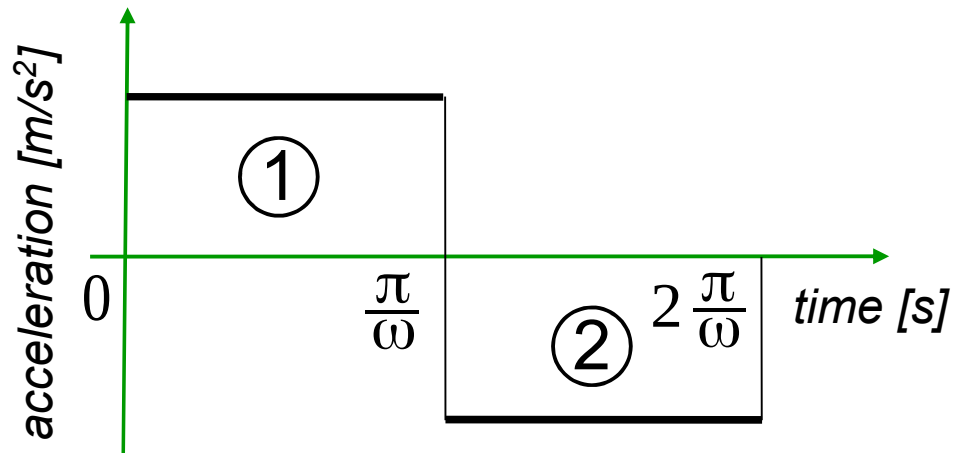

Cam base-radius

$$h_1(t=0) = h_2(t=2\frac{\pi}{\omega}) = R$$

$$a_1 = a_0$$

$$a_2 = -a_0$$

$$v_1(t) = a_0 t + C_1$$

$$v_2(t) = -a_0 t + C_3$$

$$h_1(t) = \frac{a_0 t^2}{2} + C_1 t + C_2 \quad h_2(t) = \frac{-a_0 t^2}{2} + C_3 t + C_4$$

Synthesis of cam-follower mechanisms

Analytical method – example

Design profile of a cam cooperating with eccentric knife-edge follower to obtain constant acceleration of uplift and downlift with constant angular velocity.

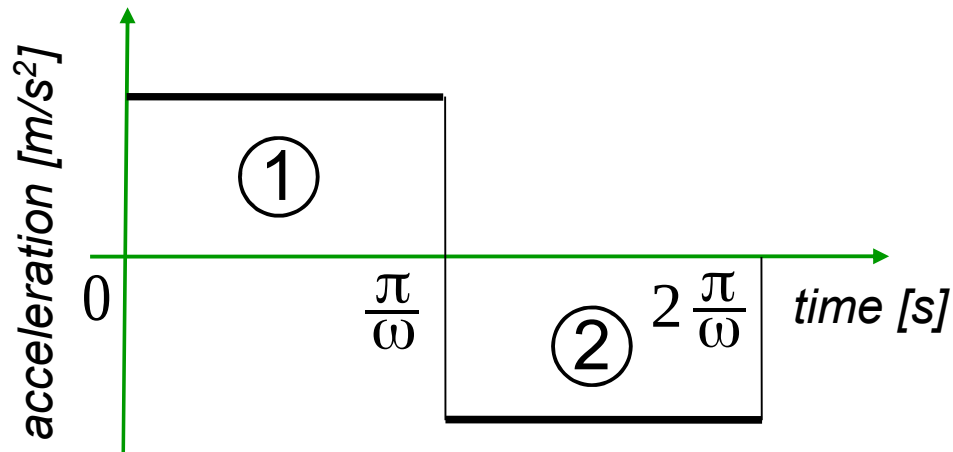

Cam base-radius

$$h_1(t=0) = h_2(t=2\frac{\pi}{\omega}) = R$$

$$C_2 = R$$

$$C_4 = R + 2a_0 \frac{\pi^2}{\omega^2} - 2C_3 \frac{\pi}{\omega}$$

$$a_1 = a_0$$

$$a_2 = -a_0$$

$$v_1(t) = a_0 t + C_1$$

$$v_2(t) = -a_0 t + C_3$$

$$h_1(t) = \frac{a_0 t^2}{2} + C_1 t + C_2 \quad h_2(t) = \frac{-a_0 t^2}{2} + C_3 t + C_4$$

Synthesis of cam-follower mechanisms

Analytical method – example

Design profile of a cam cooperating with eccentric knife-edge follower to obtain constant acceleration of uplift and downlift with constant angular velocity.

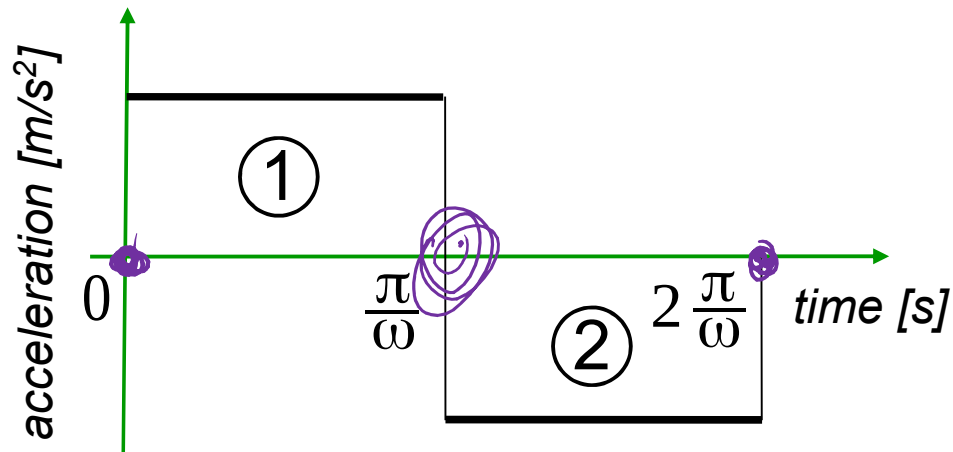

Cam base-radius

$$h_1(t=0) = h_2(t=2\frac{\pi}{\omega}) = R$$

$$C_2 = R$$

$$C_4 = R + 2a\frac{\pi^2}{\omega^2} - 2C_3\frac{\pi}{\omega}$$

$$a_1 = a_0$$

$$a_2 = -a_0$$

$$v_1(t) = a_0 t + C_1$$

$$v_2(t) = -a_0 t + C_3$$

$$h_1(t) = \frac{a_0 t^2}{2} + C_1 t + R \quad h_2(t) = \frac{-a_0 t^2}{2} + C_3 t + R + 2a_0 \frac{\pi^2}{\omega^2} - 2C_3 \frac{\pi}{\omega}$$

$$h_1(t=\frac{\pi}{\omega}) = h_2(t=\frac{\pi}{\omega})$$

Synthesis of cam-follower mechanisms

Analytical method – example

Design profile of a cam cooperating with eccentric knife-edge follower to obtain constant acceleration of uplift and downlift with constant angular velocity.

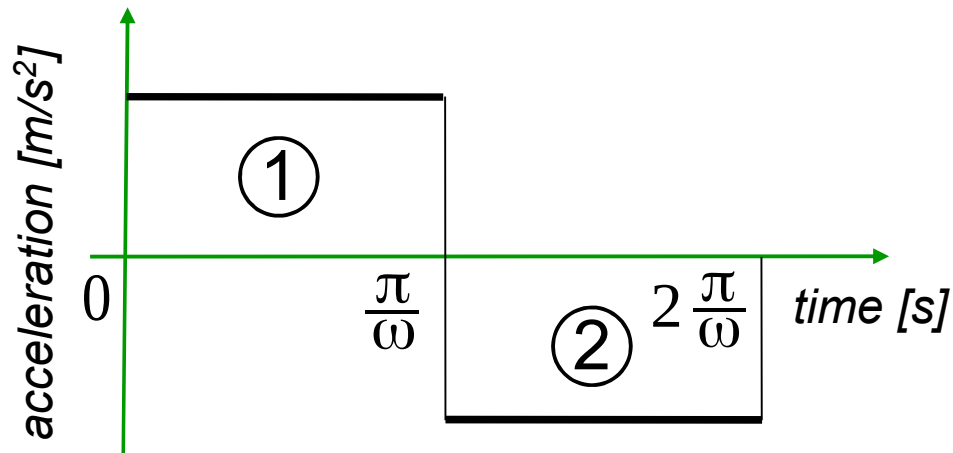

Cam outline continuity

$$h_2\left(t = \frac{\pi}{\omega}\right) = h_1\left(t = \frac{\pi}{\omega}\right)$$

$$a_1 = a_0$$

$$a_2 = -a_0$$

$$v_1(t) = a_0 t + C_1$$

$$v_2(t) = -a_0 t + C_3$$

$$h_1(t) = \frac{a_0 t^2}{2} + C_1 t + R \quad h_2(t) = \frac{-a_0 t^2}{2} + C_3 t + R + 2a_0 \frac{\pi^2}{\omega^2} - 2C_3 \frac{\pi}{\omega}$$

$$a_0 \frac{\pi^2}{2\omega^2} + C_1 \frac{\pi}{\omega} + R = -a_0 \frac{\pi^2}{2\omega^2} + C_3 \frac{\pi}{\omega} + 2a_0 \frac{\pi^2}{\omega^2} - 2C_3 \frac{\pi}{\omega}$$

Synthesis of cam-follower mechanisms

Analytical method – example

Design profile of a cam cooperating with eccentric knife-edge follower to obtain constant acceleration of uplift and downlift with constant angular velocity.

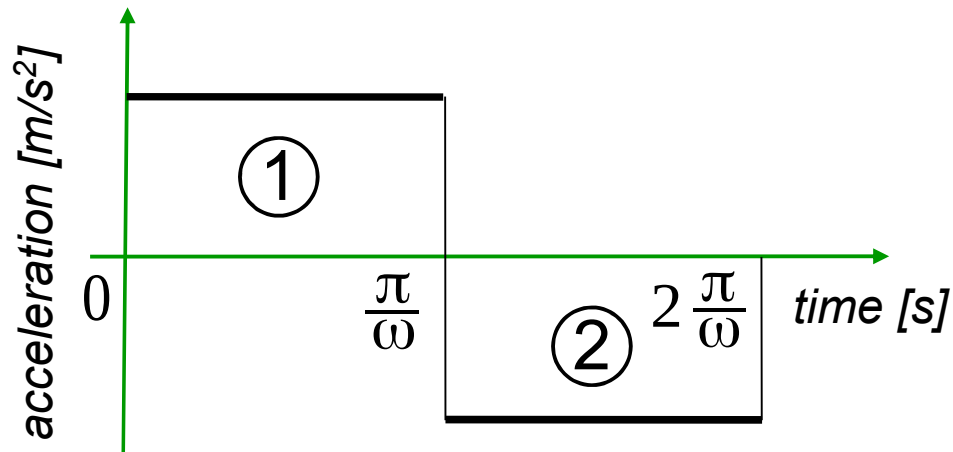

Cam outline continuity

$$h_2\left(t = \frac{\pi}{\omega}\right) = h_1\left(t = \frac{\pi}{\omega}\right)$$

$$C_3 = a_0 \frac{\pi}{\omega} - C_1$$

$$a_1 = a_0$$

$$v_1(t) = a_0 t + C_1$$

$$h_1(t) = \frac{a_0 t^2}{2} + C_1 t + R$$

$$a_2 = -a_0$$

$$v_2(t) = -a_0 t + C_3$$

$$h_2(t) = \frac{-a_0 t^2}{2} + C_3 t + R + 2a_0 \frac{\pi^2}{\omega^2} - 2C_3 \frac{\pi}{\omega}$$

Synthesis of cam-follower mechanisms

Analytical method – example

Design profile of a cam cooperating with eccentric knife-edge follower to obtain constant acceleration of uplift and downlift with constant angular velocity.

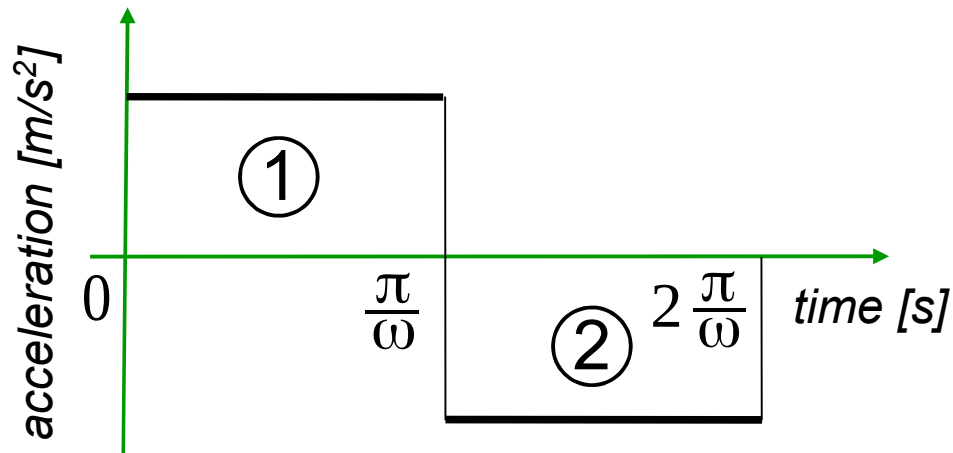

Cam outline continuity

$$h_2\left(t = \frac{\pi}{\omega}\right) = h_1\left(t = \frac{\pi}{\omega}\right)$$

$$C_3 = a_0 \frac{\pi}{\omega} - C_1$$

$$a_1 = a_0$$

$$a_2 = -a_0$$

$$v_1(t) = a_0 t + C_1$$

$$v_2(t) = -a_0 t + a_0 \frac{\pi}{\omega} - C_1$$

$$h_1(t) = \frac{a_0 t^2}{2} + C_1 t + R \quad h_2(t) = \frac{-a_0 t^2}{2} + R + a_0 \frac{\pi}{\omega} t + C_1 \left(2 \frac{\pi}{\omega} - t\right)$$

Synthesis of cam-follower mechanisms

Analytical method – example

Design profile of a cam cooperating with eccentric knife-edge follower to obtain constant acceleration of uplift and downlift with constant angular velocity.

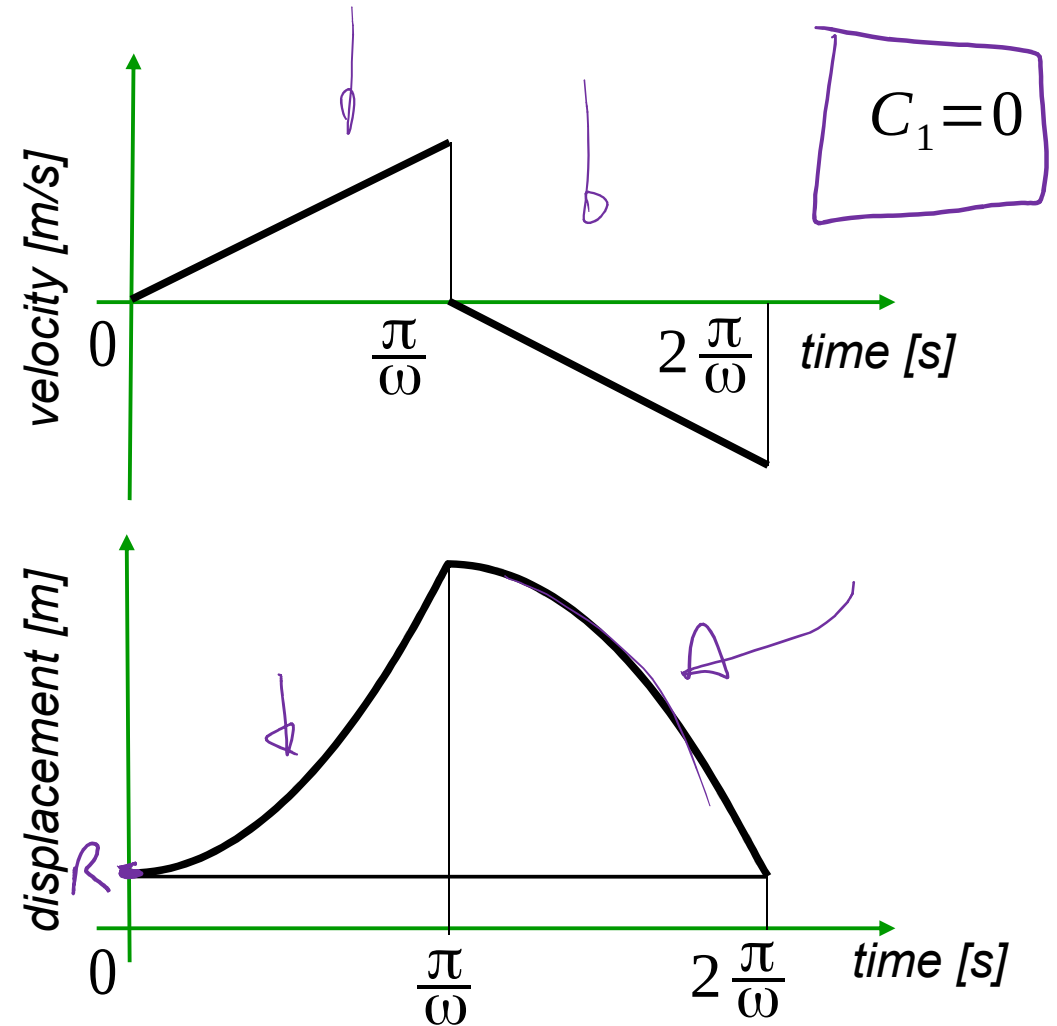
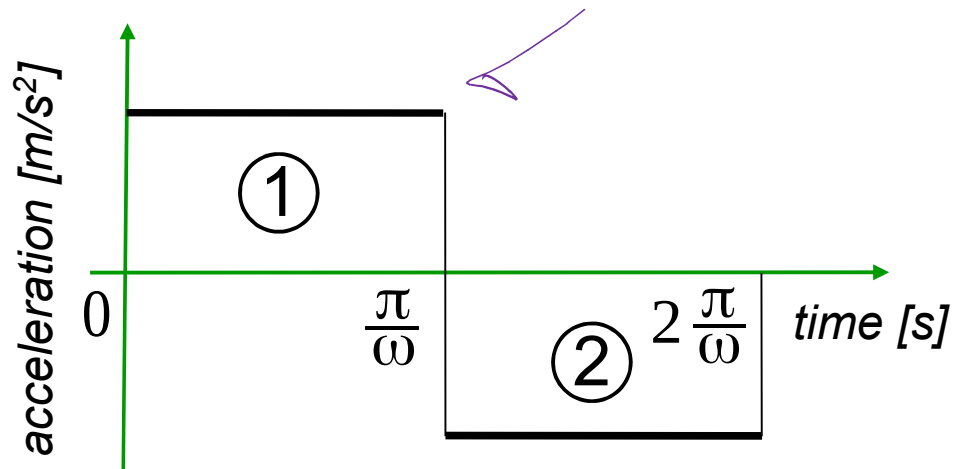

Synthesis of cam-follower mechanisms

Analytical method – example

Design profile of a cam cooperating with eccentric knife-edge follower to obtain constant acceleration of uplift and downlift with constant angular velocity.

$$h(t) = \begin{cases} \frac{a_0 t^2}{2} + C_1 t + R, & \text{for } t \in (0, \frac{\pi}{\omega}) \\ -\frac{a_0 t^2}{2} + R + a_0 \frac{\pi}{\omega} t + C_1 (2 \frac{\pi}{\omega} - t), & \text{for } t \in (\frac{\pi}{\omega}, 2 \frac{\pi}{\omega}) \end{cases}$$

Synthesis of cam-follower mechanisms

Analytical method – example

Design profile of a cam cooperating with eccentric knife-edge follower to obtain constant acceleration of uplift and downlift with constant angular velocity.

$$h(t) = \begin{cases} \frac{a_0 t^2}{2} + C_1 t + R, & \text{for } t \in (0, \frac{\pi}{\omega}) \\ -\frac{a_0 t^2}{2} + R + a_0 \frac{\pi}{\omega} t + C_1 (2 \frac{\pi}{\omega} - t), & \text{for } t \in (\frac{\pi}{\omega}, 2 \frac{\pi}{\omega}) \end{cases}$$

With follower offset consideration

$$\rho(t) = \sqrt{h^2(t) + m^2}$$

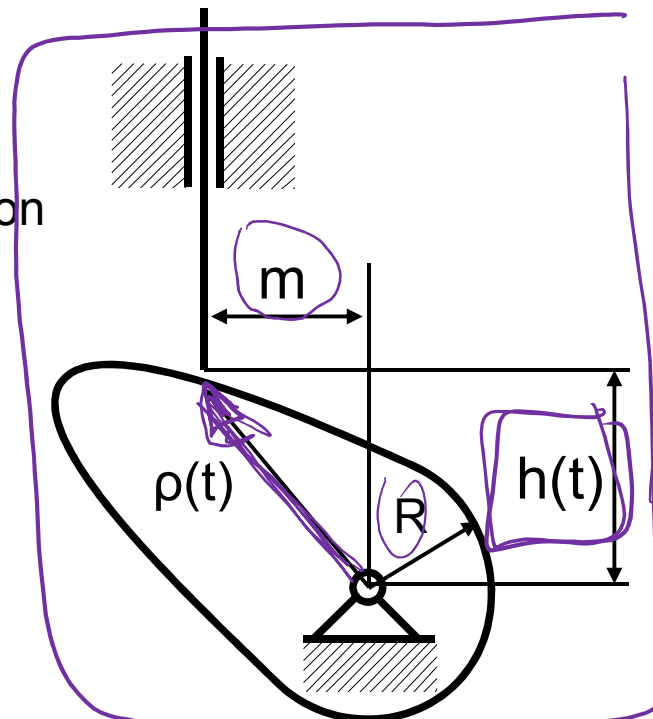

From polar to Cartesian coordinate

$$\begin{aligned} x(t) &= \rho(t) \cos \omega t \\ y(t) &= \rho(t) \sin \omega t \end{aligned}$$

Synthesis of cam-follower mechanisms

Analytical method – example

$$C_1 = 0$$

$$m = 0$$

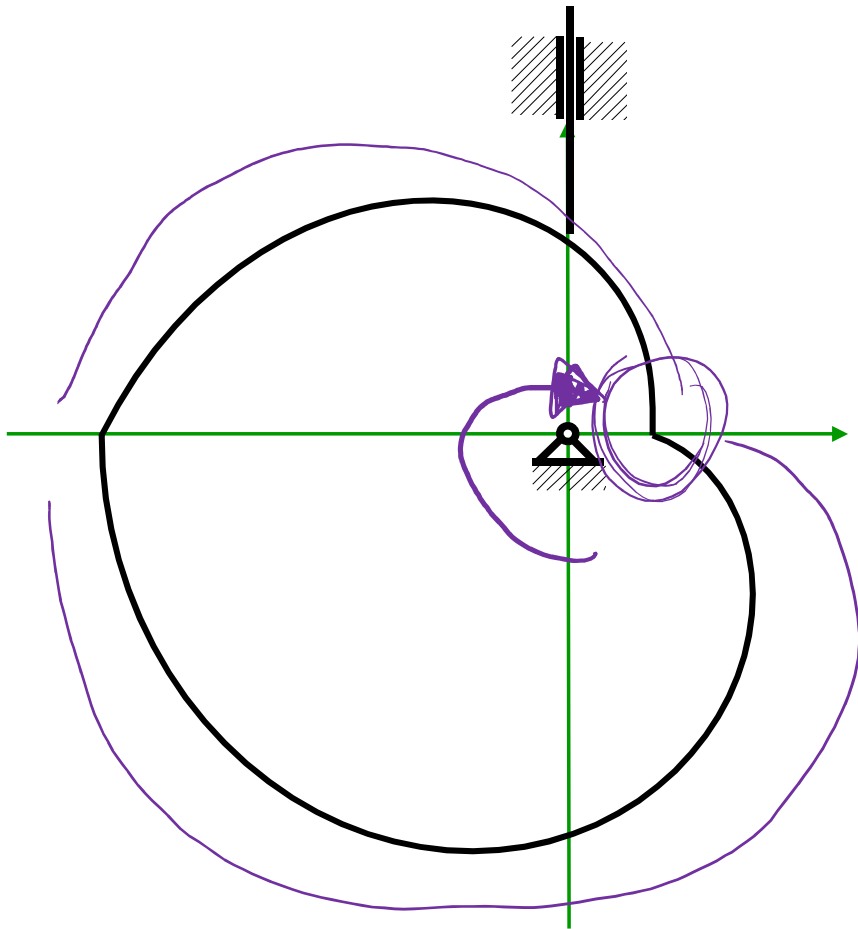

$$m \neq 0$$

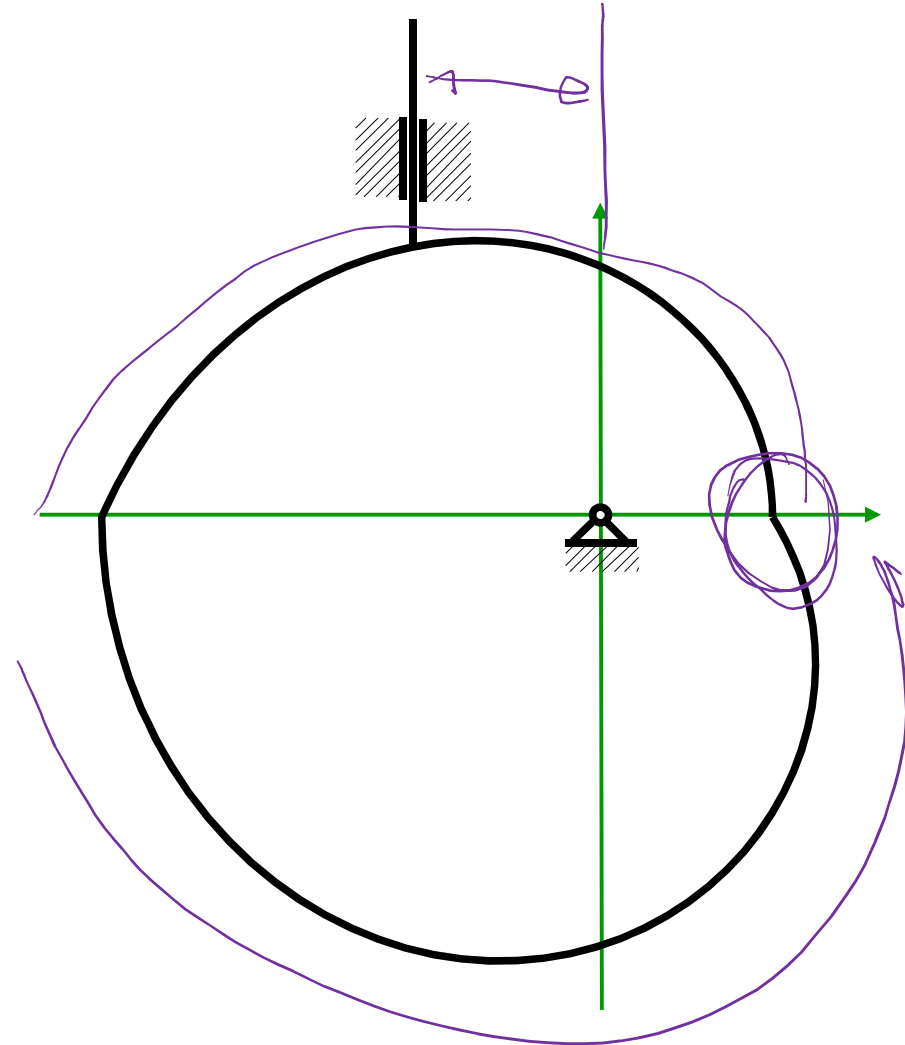

Synthesis of cam-follower mechanisms

Analytical method – example

Design profile of a cam cooperating with eccentric knife-edge follower to obtain constant acceleration of uplift and downlift with constant angular velocity.

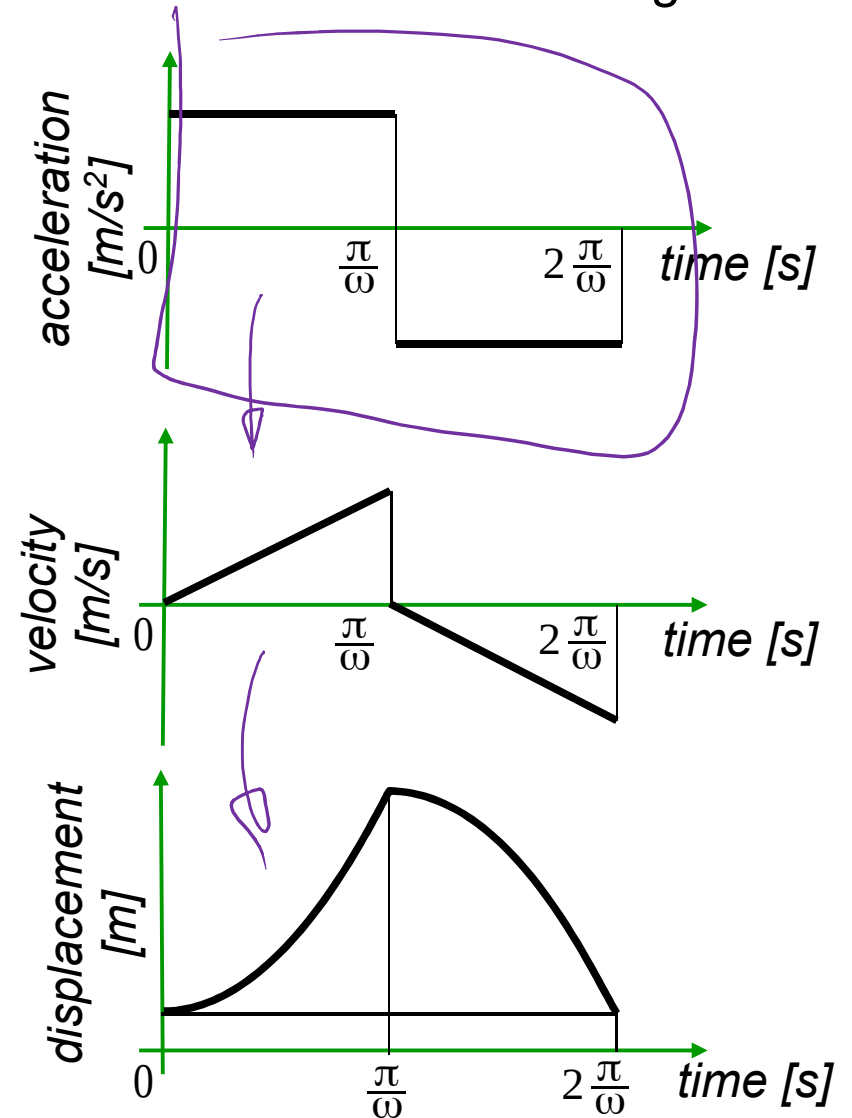
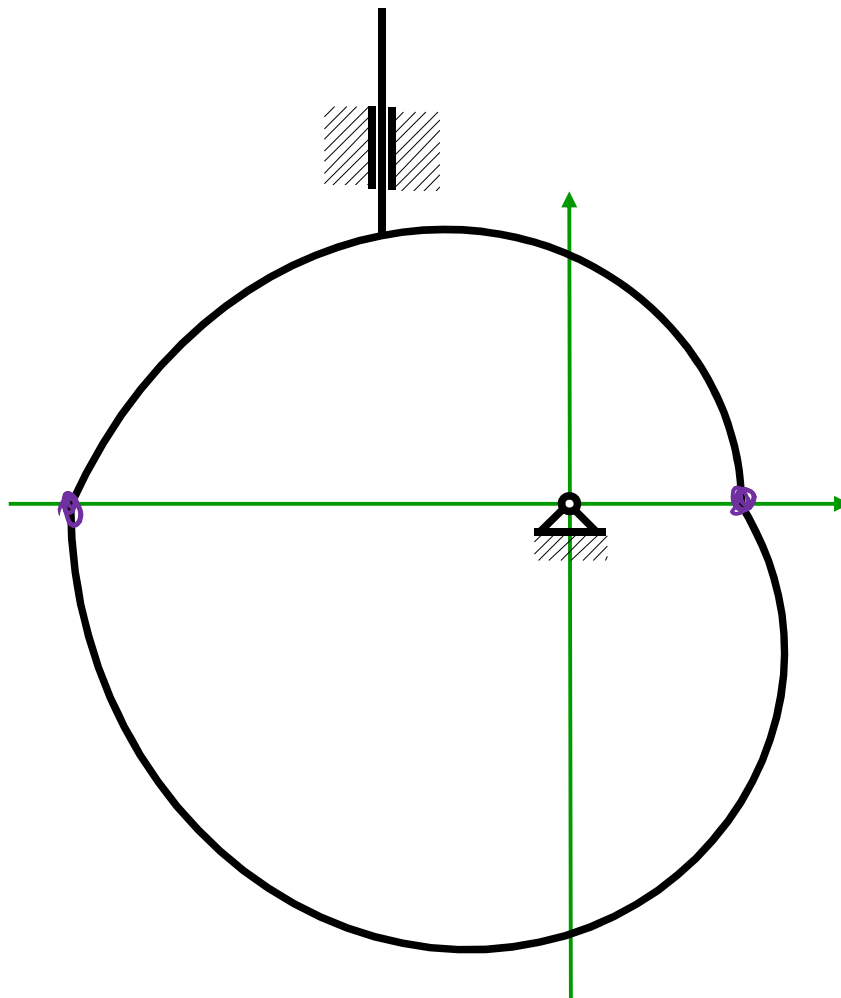

Synthesis of cam-follower mechanisms

Analytical method – example 2

Design profile of a cam cooperating with centric knife-edge follower to obtain harmonic acceleration with constant angular velocity.

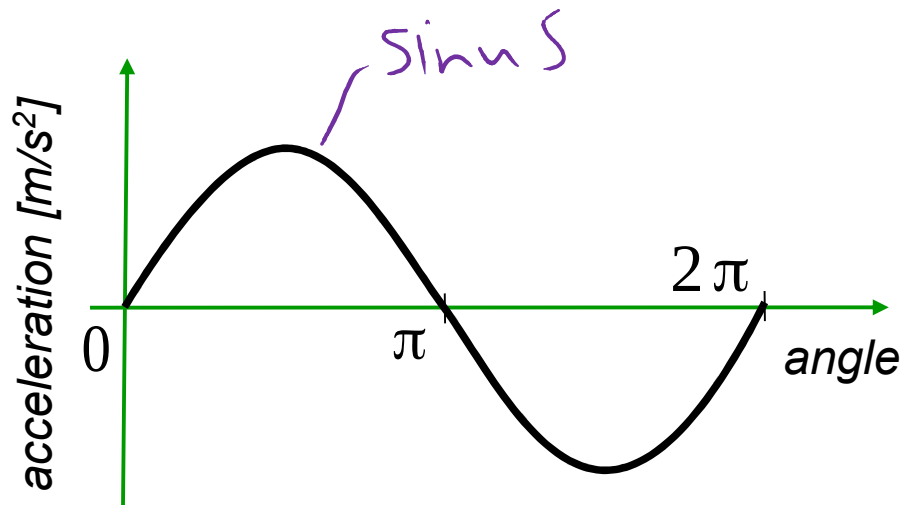

Cam-follower mechanisms

Distance of contact and angle of contact

x

α

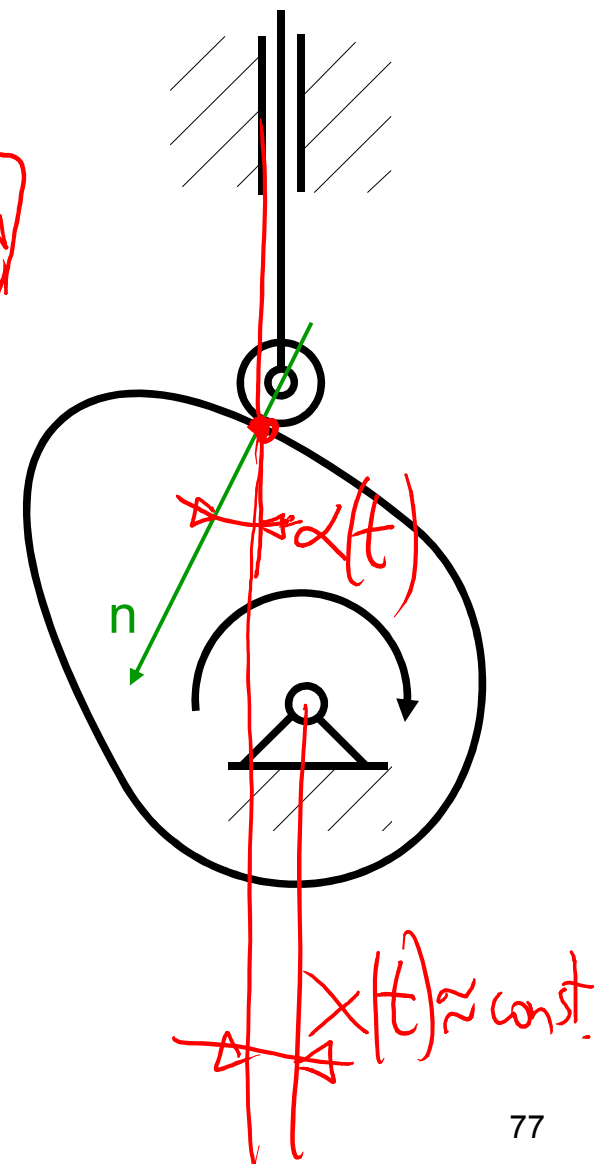
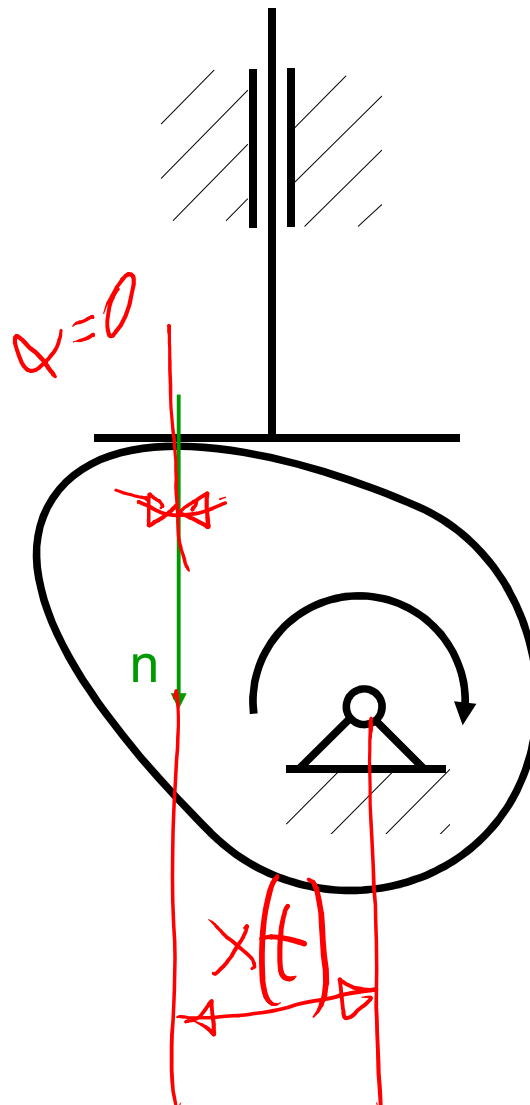
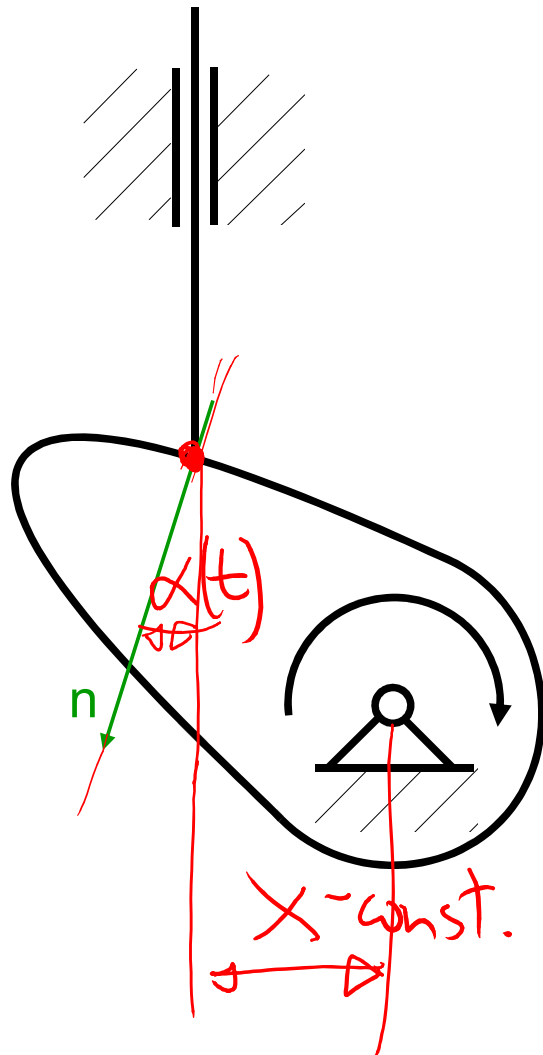

Cam-follower mechanisms

Distance of contact and angle of contact

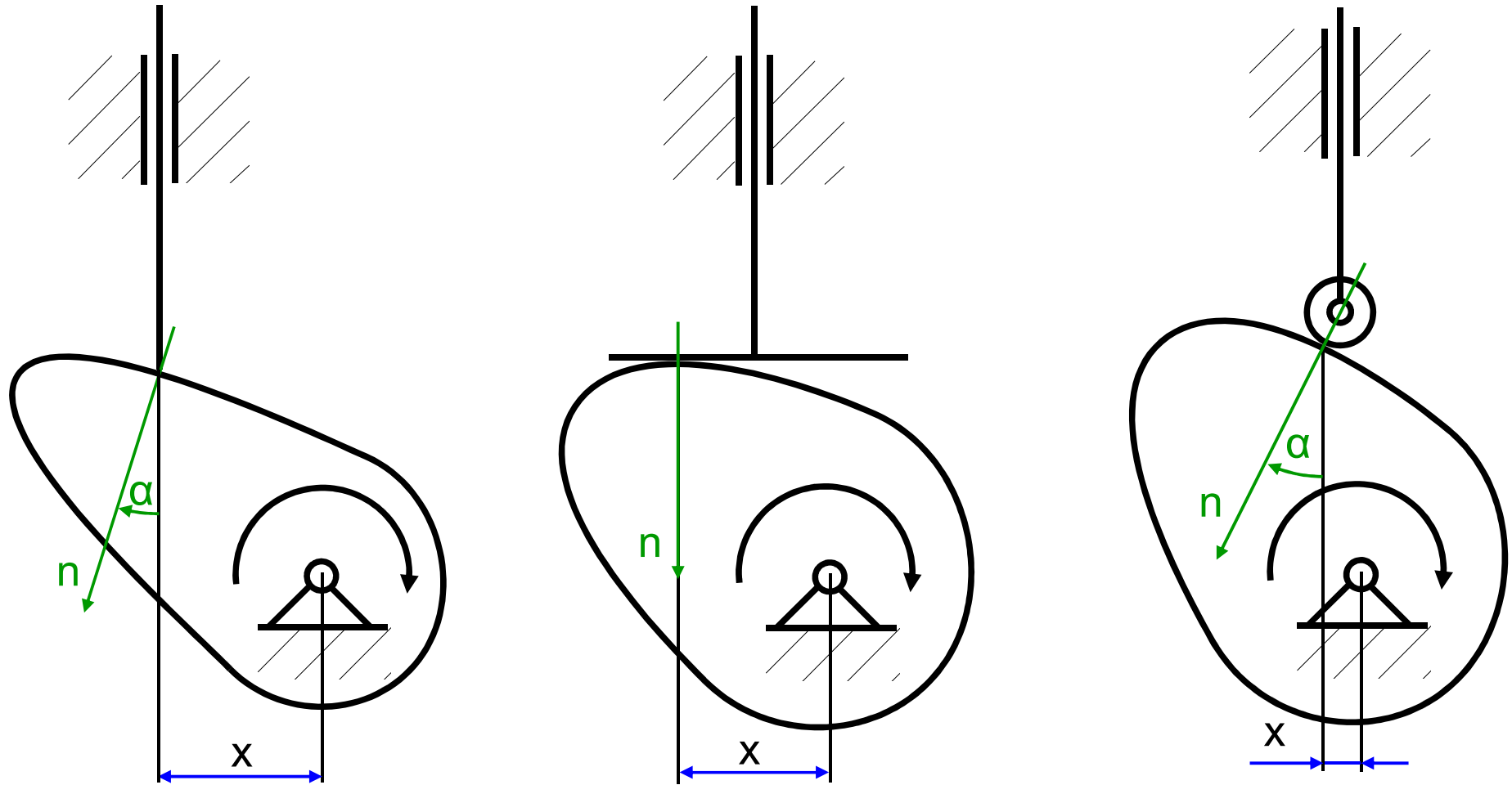

Cam-follower mechanisms

Distance of contact and angle of contact

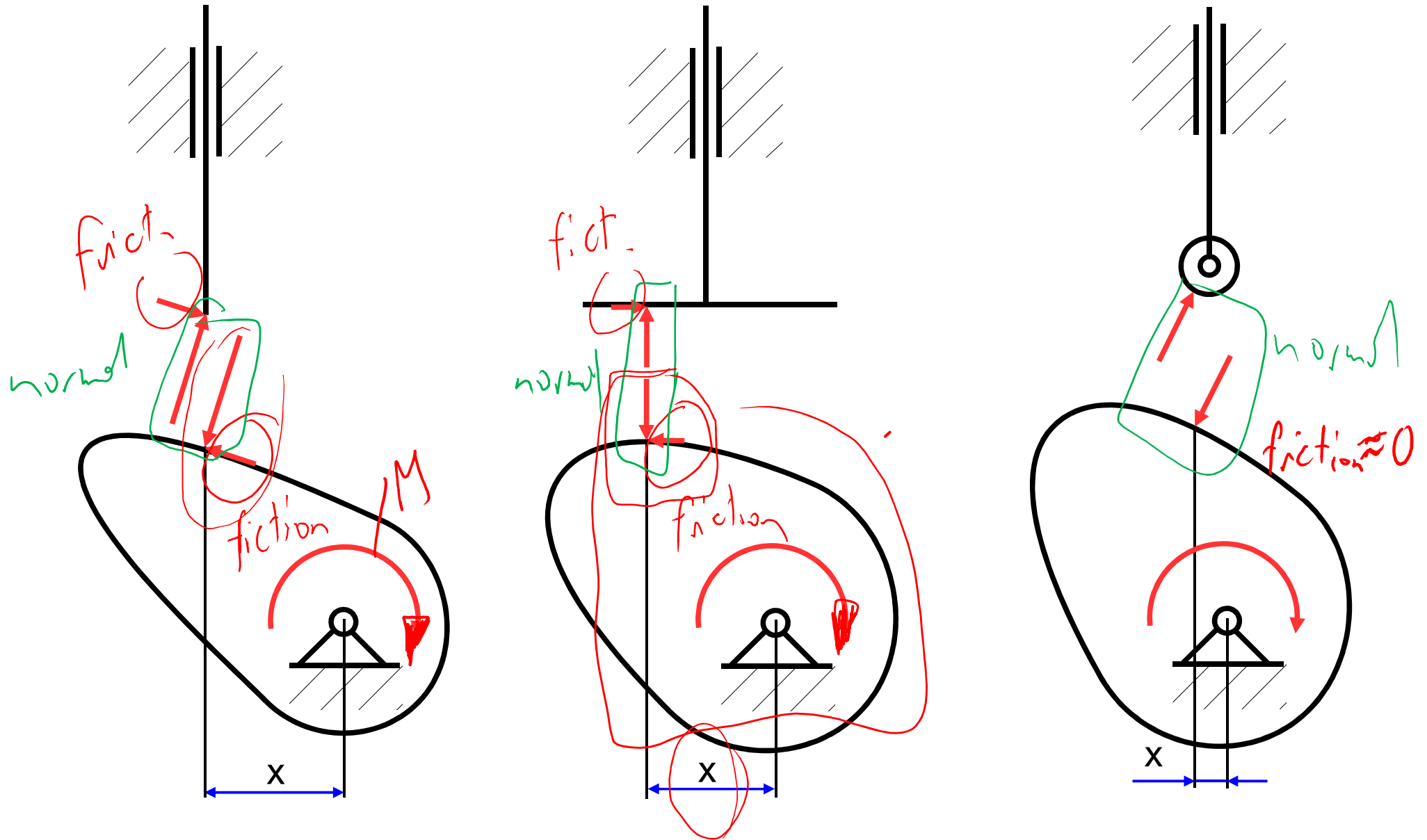

Cam-follower mechanisms

Minimal cam size

1st condition: minimum cam radius of curvature in case of material strength and wear resistance.

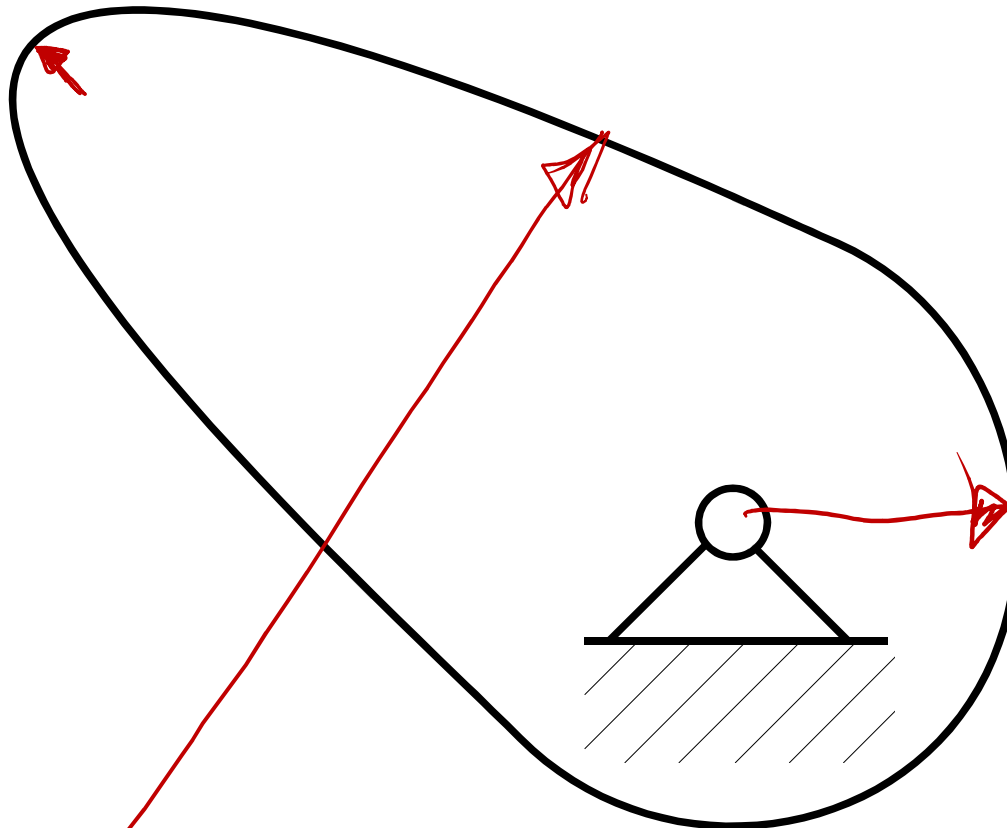

Cam-follower mechanisms

Minimal cam size

2nd condition: maximum angle of contact in case of follower bending resistance and pressure inside the socket.

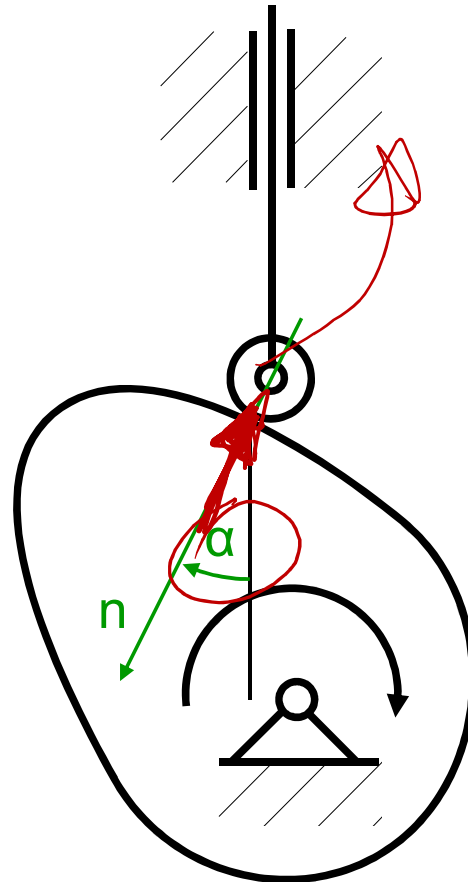

Cam-follower mechanisms

Minimal cam size

3rd condition: maximum distance of contact in case of follower's stem bending (for a flat-faced followers).

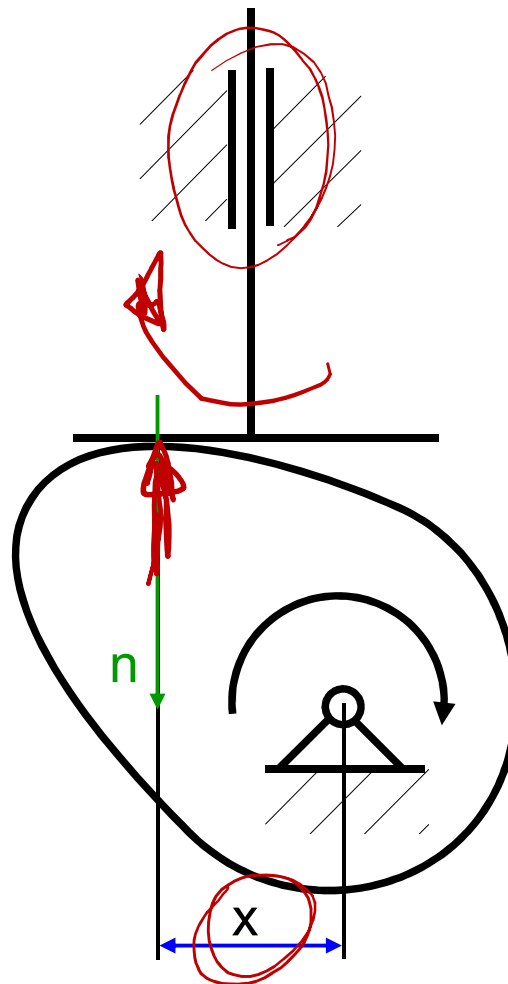

Cam-follower mechanisms

Minimal cam size

Follower offset towards direction opposite to direction of rotation decreases maximum angle of contact

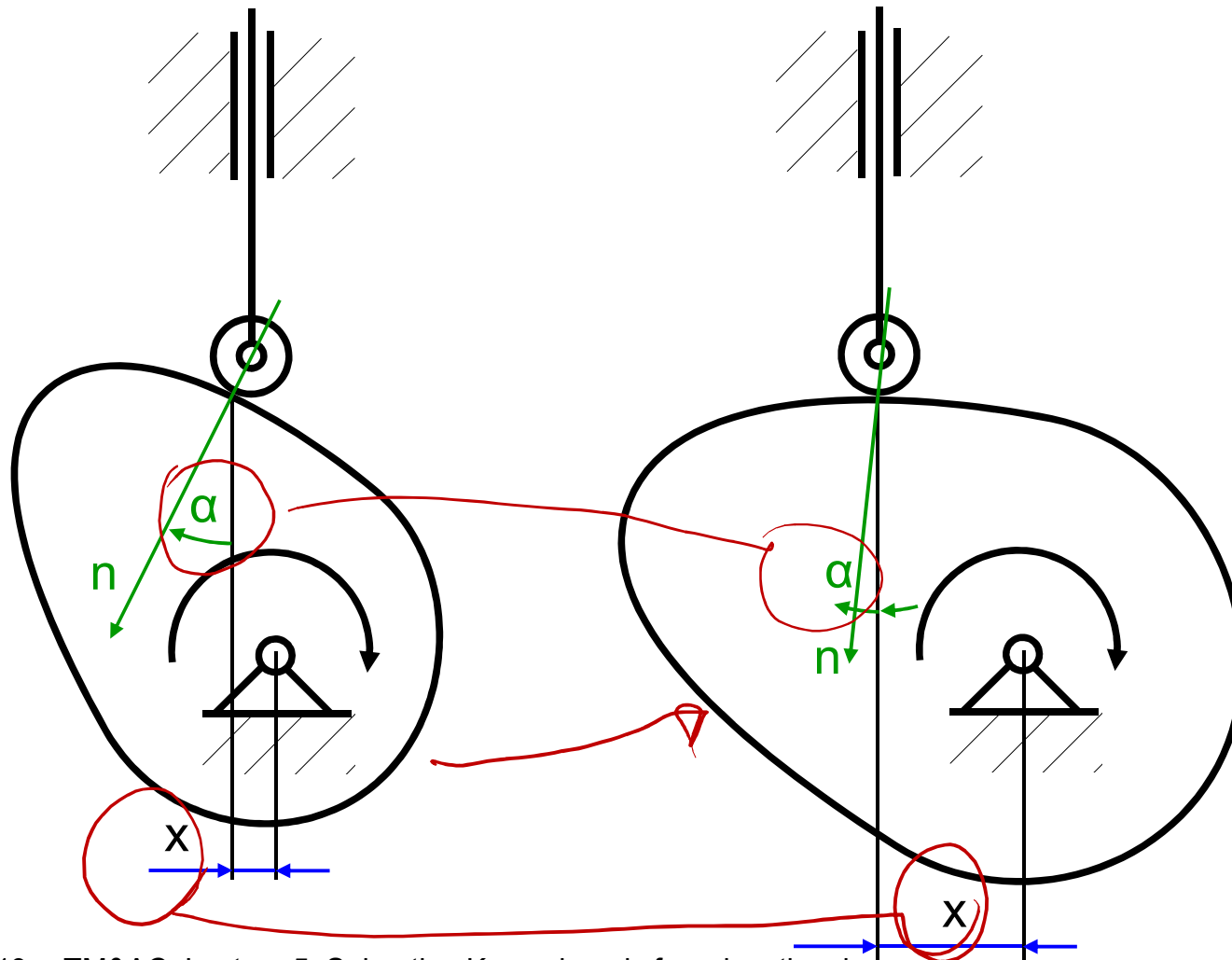

Dynamics of planar mechanisms

Overview

Members description as rigid bodies and and material points.

Graphical determination of inertial forces and torques.

Reaction forces in kinematic pairs.

Driving and operating forces/torques.

Inverse and direct dynamics problems.

Graphical, analytical and graphical-analytical method.

~~Friction in kinematic pairs.~~

Dynamics of planar mechanisms

Members description

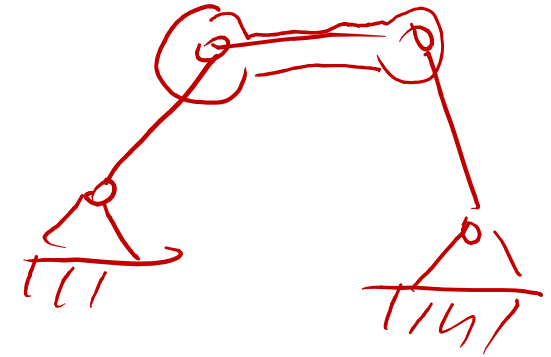

For a planar mechanism member
represented by a rigid body:

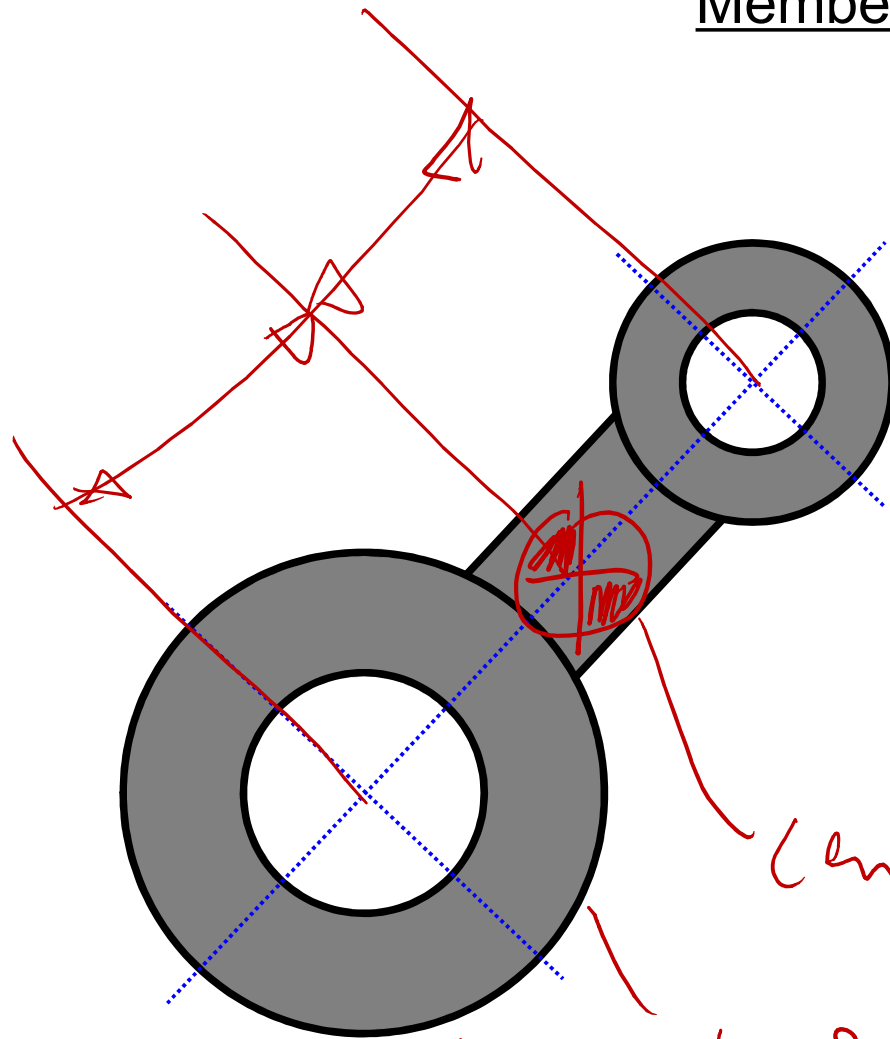

Center of mass
mass!

mass moment of inertia

Dynamics of planar mechanisms

Members description

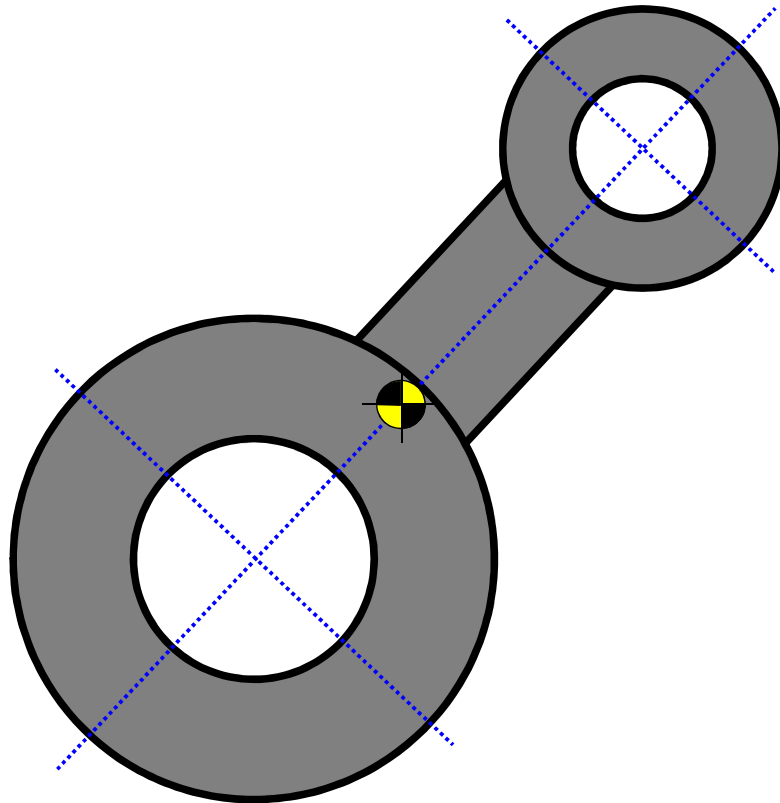

For a planar mechanism member represented by a rigid body:

- mass
- location of a center of a mass
- mass moment of inertia wrt the axis perpendicular to the motion plane in center of a mass
- location of connection points

Dynamics of planar mechanisms

Members description

Material points method

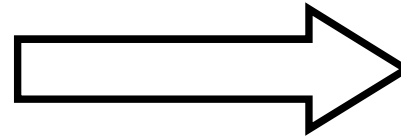
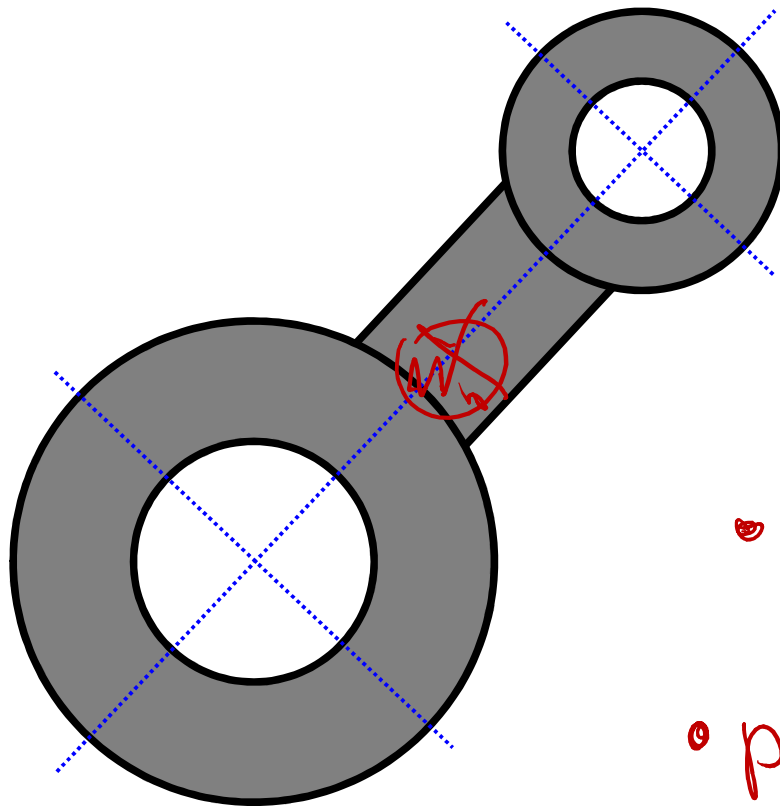

a set of material points

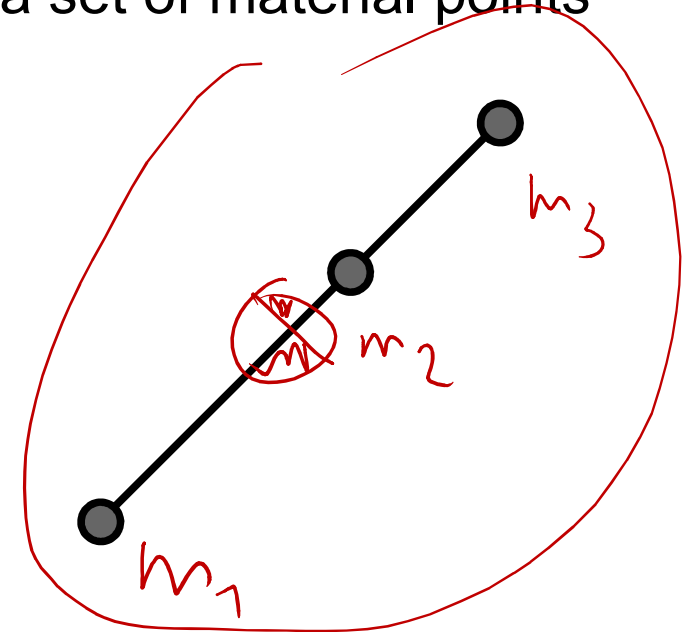

- total mass
- pos. of center of mass
- moment of inertia

Dynamics of planar mechanisms

Members description

Material points method

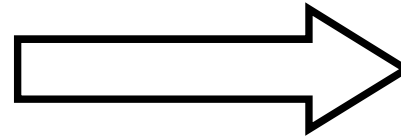
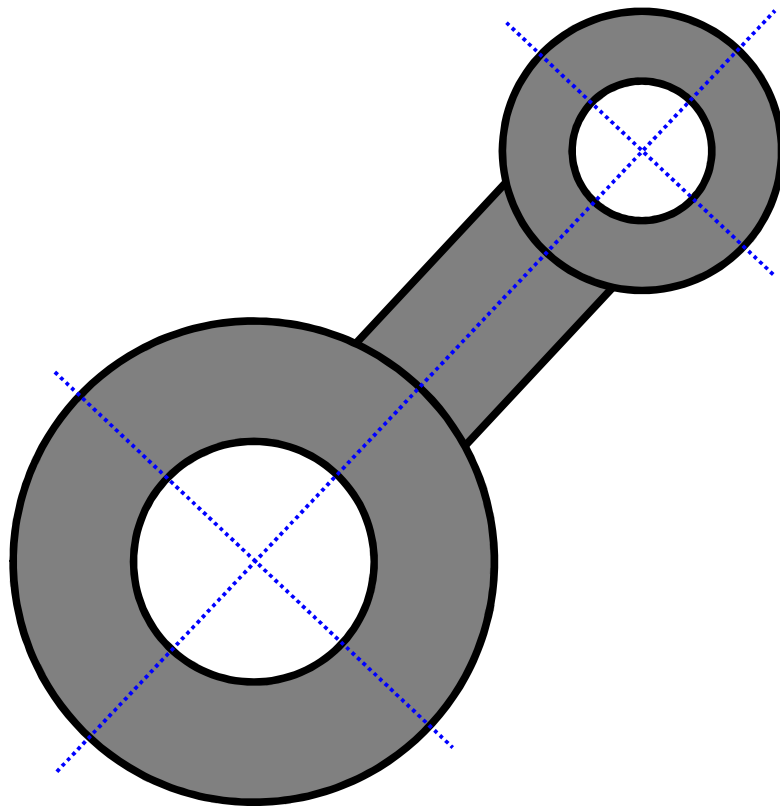

a set of material points

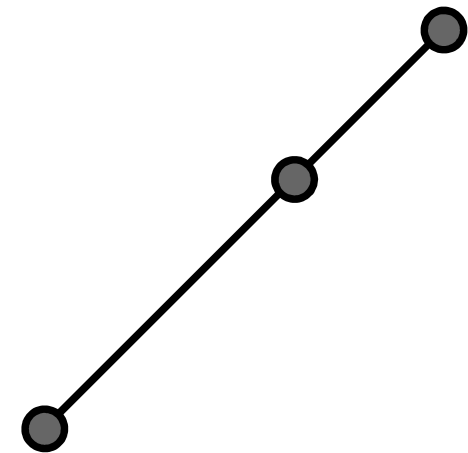

- same masses
- same center of mass
- same inertia

Dynamics of planar mechanisms

Members description

Material points method - example

Given:

Geometry, mass m ,
center of a mass location
(pt. C) and mass moment
of inertia I_C

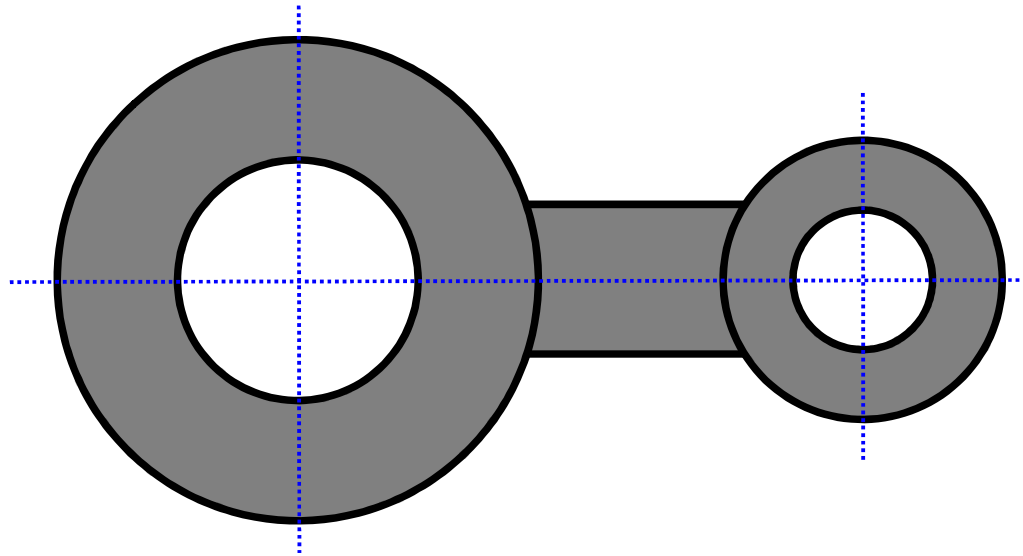

Dynamics of planar mechanisms

Members description

Material points method - example

Given:

Geometry, mass m ,
center of a mass location
(pt. C) and mass moment
of inertia I_C

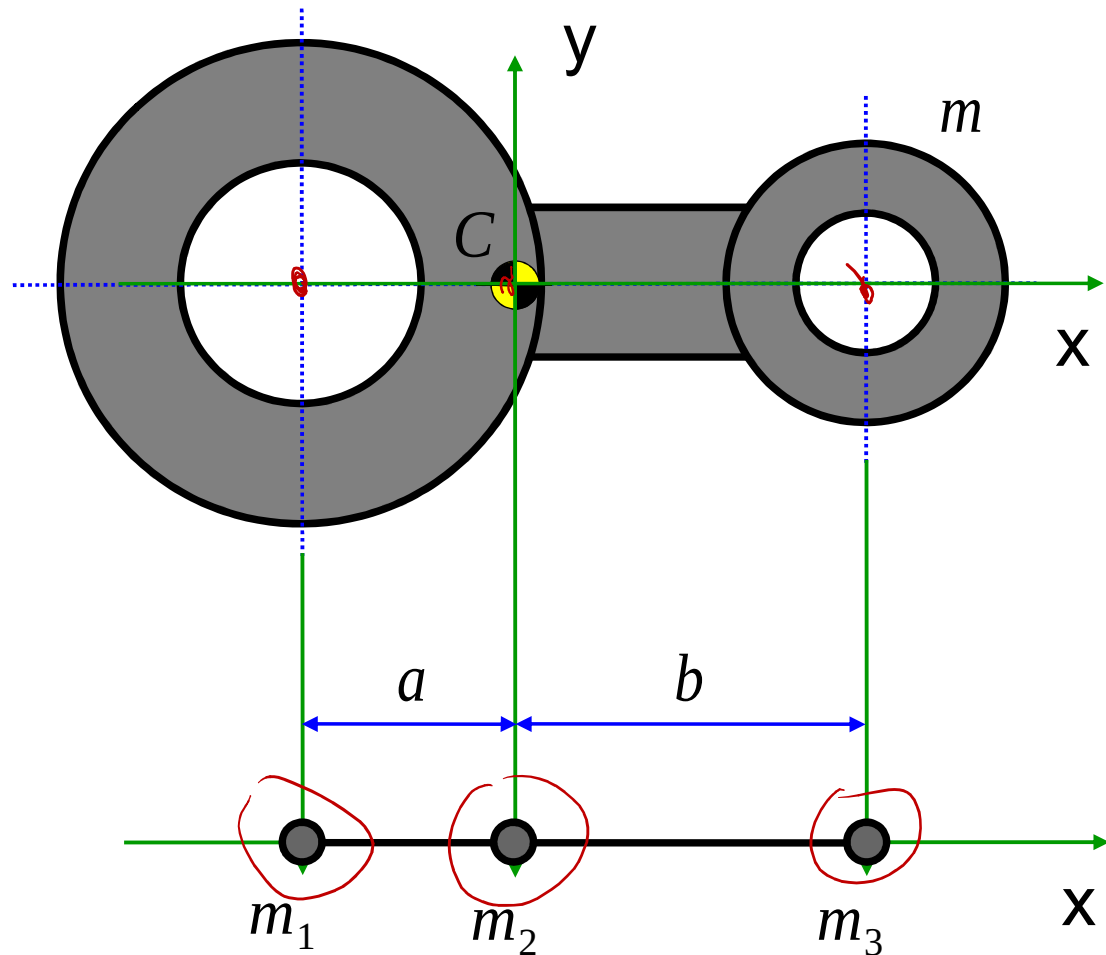

Dynamics of planar mechanisms

Members description

Material points method - example

Given:

Geometry, mass m ,
center of a mass location
(pt. C) and mass moment
of inertia I_C

$$m_1 + m_2 + m_3 = m$$

$$\frac{-am_1 + bm_3}{m_1 + m_2 + m_3} = 0$$

$$m_1 a^2 + m_3 b^2 = I_C$$

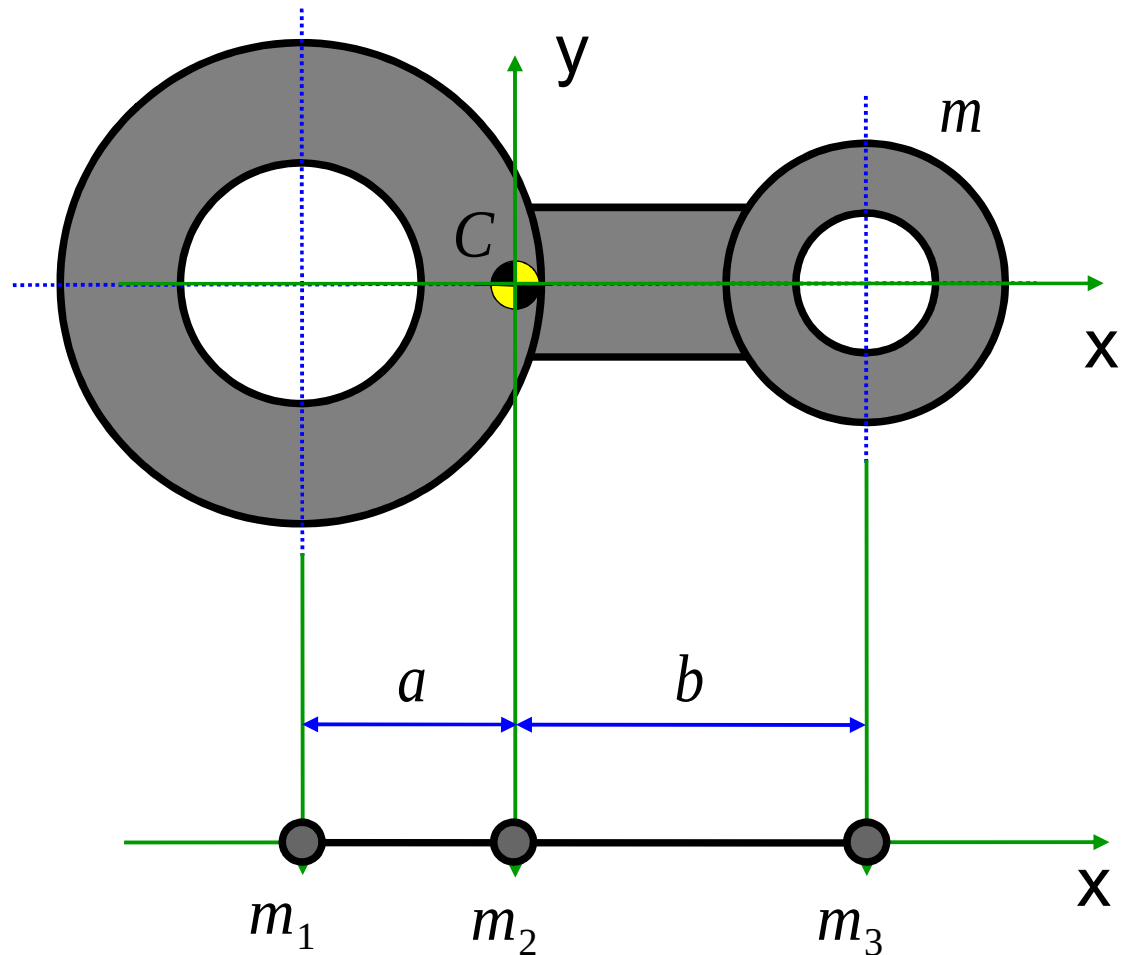

Dynamics of planar mechanisms

Inertia forces and torques

$$\vec{B}_c = -m\vec{a}_c$$
$$\vec{M} = -I_c \vec{\varepsilon}$$

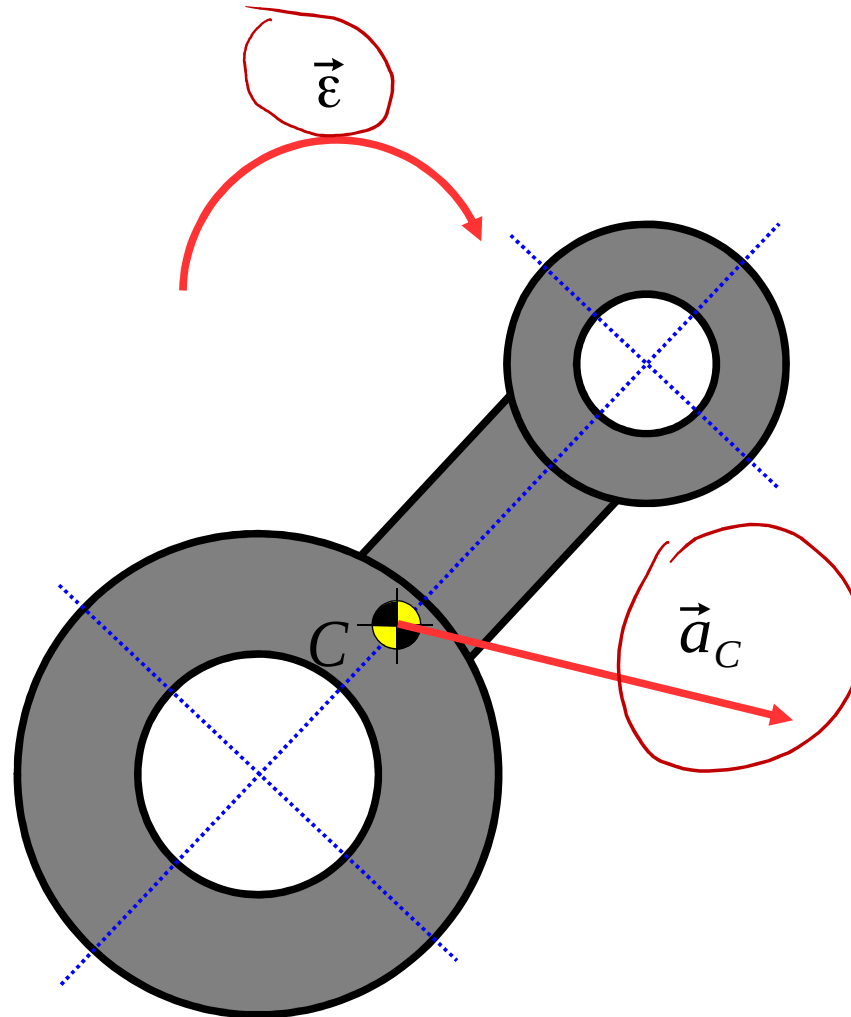

Dynamics of planar mechanisms

Inertia forces and torques

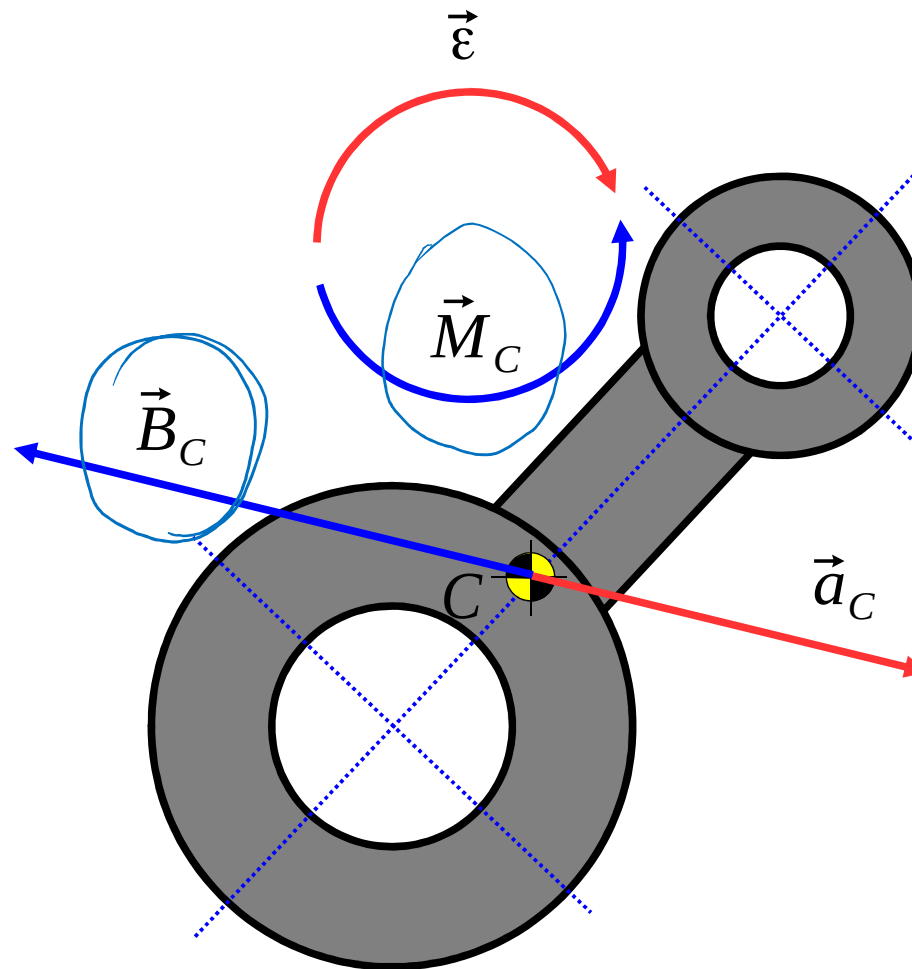

inertia force

$$\vec{B}_C = - m \vec{a}_C$$

Inertia torque

$$\vec{M}_C = - I_C \vec{\varepsilon}$$

Dynamics of planar mechanisms

Reaction forces inside a kinematic pairs (without friction)

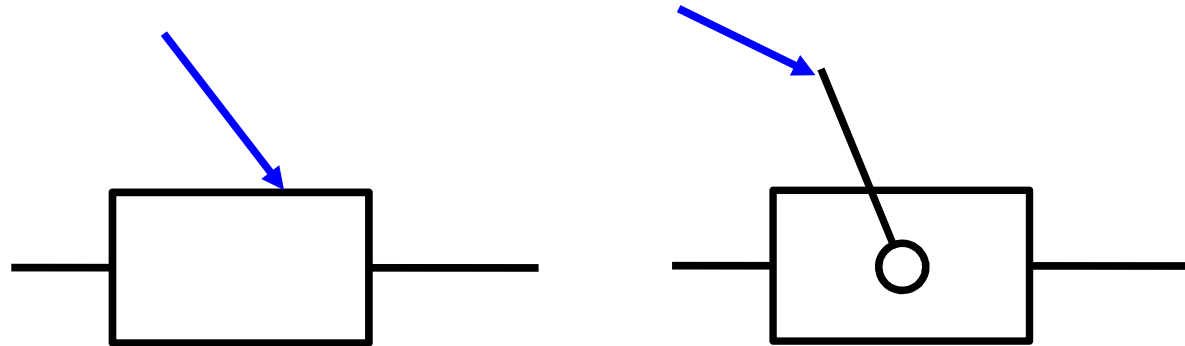

Dynamics of planar mechanisms

Reaction forces inside a kinematic pairs (without friction)

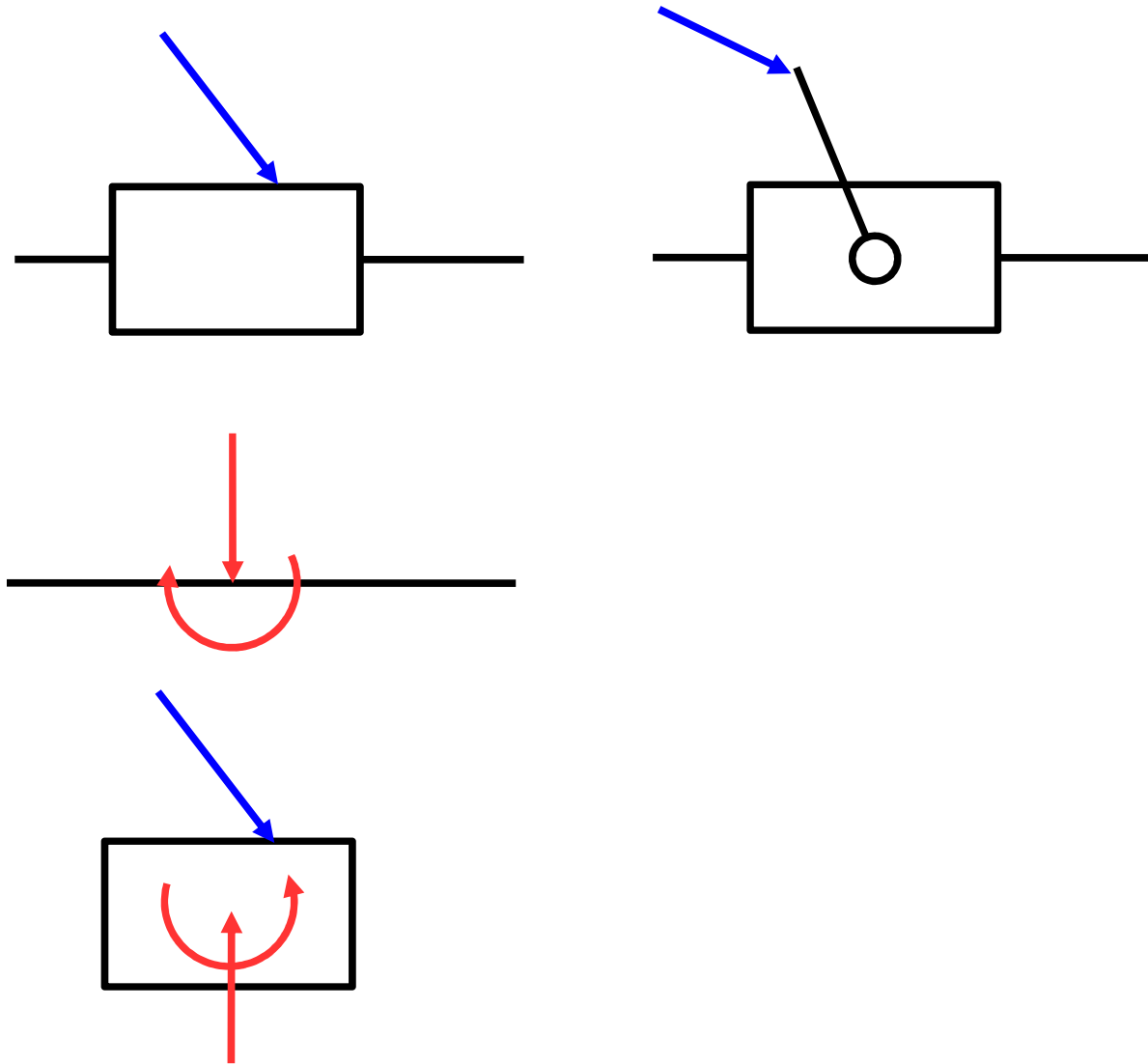

Dynamics of planar mechanisms

Reaction forces inside a kinematic pairs (without friction)

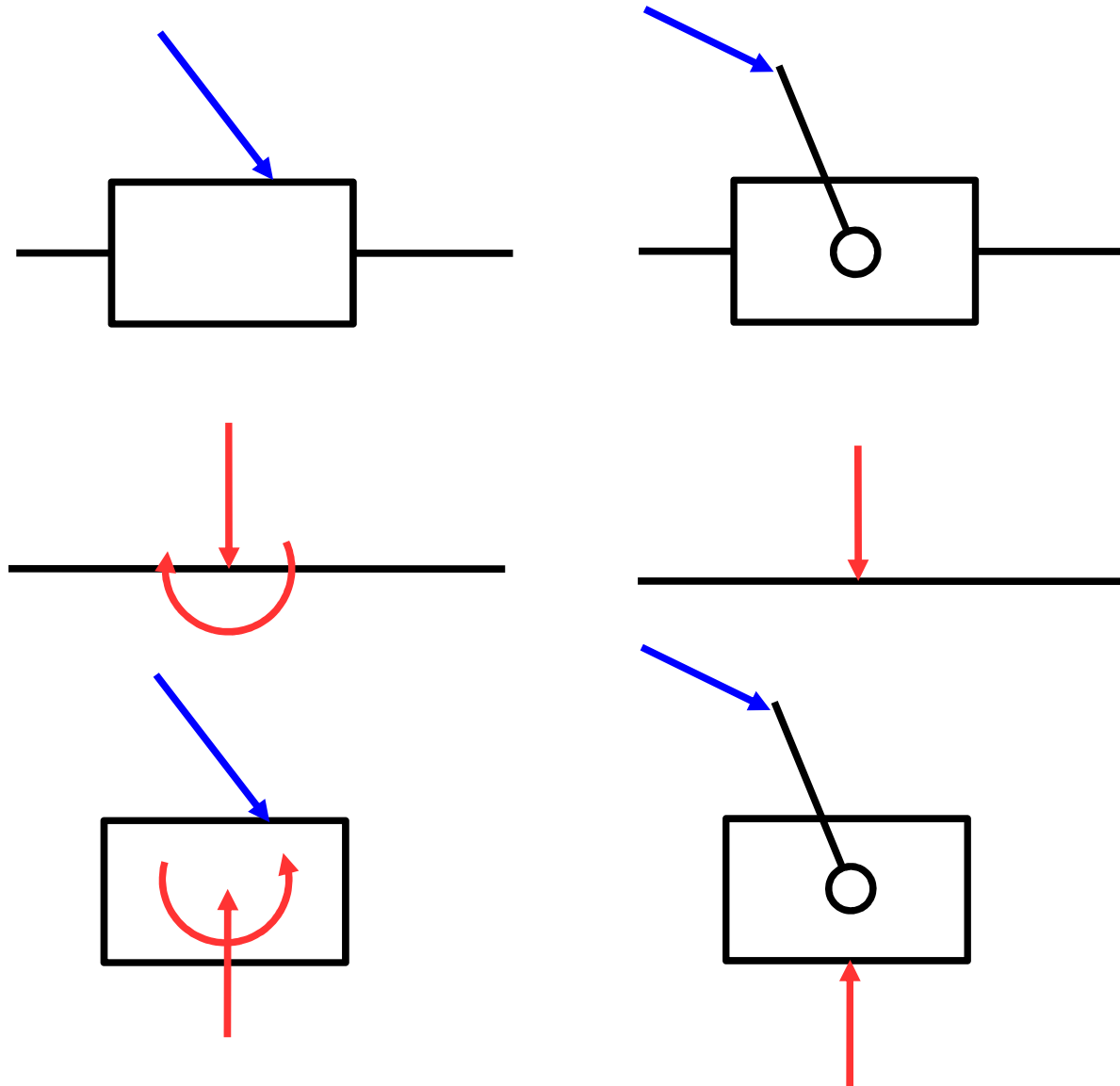

Dynamics of planar mechanisms

Reaction forces inside a kinematic pairs (without friction)

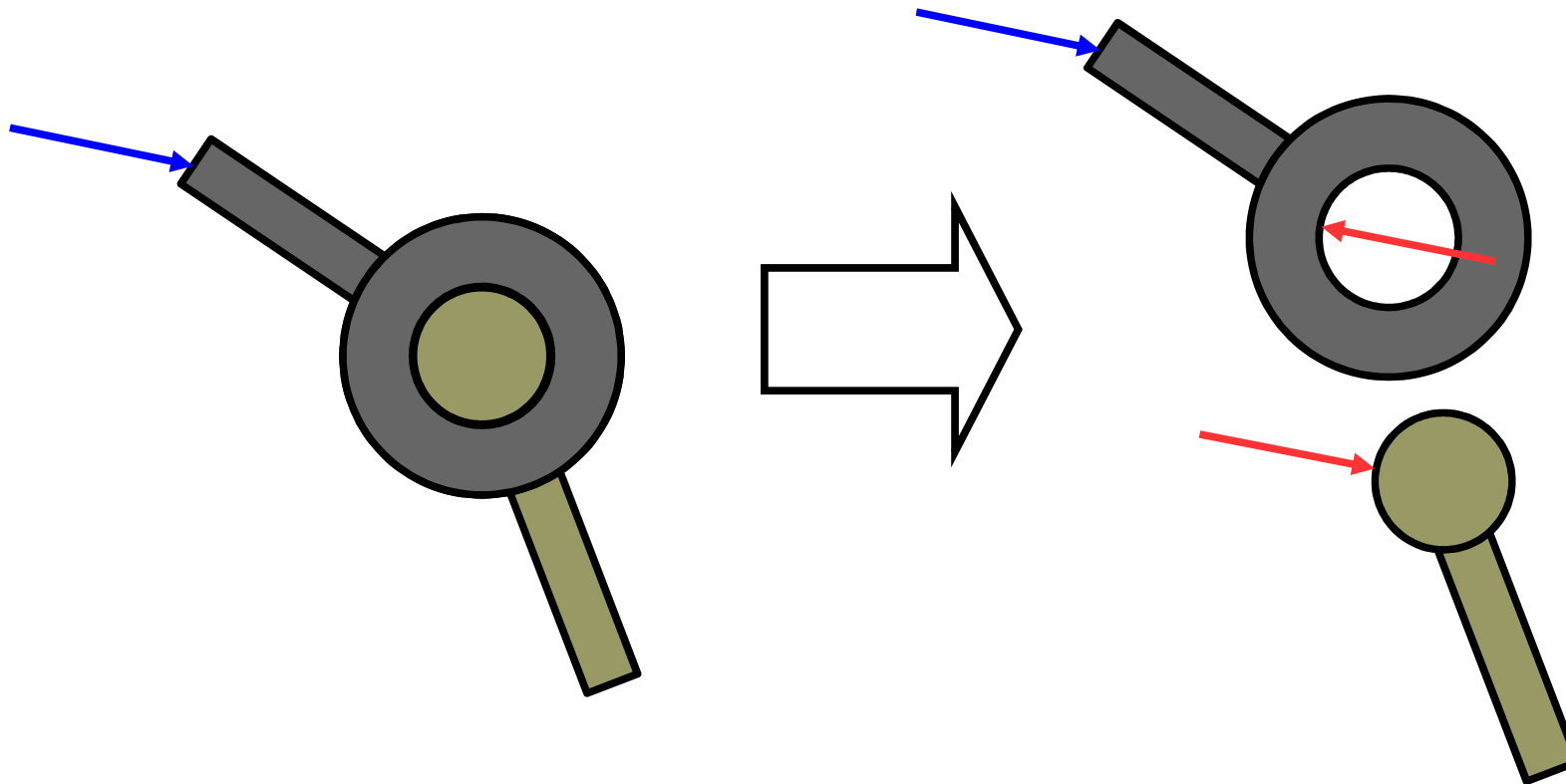

Dynamics of planar mechanisms

Reaction forces inside a kinematic pairs (without friction)

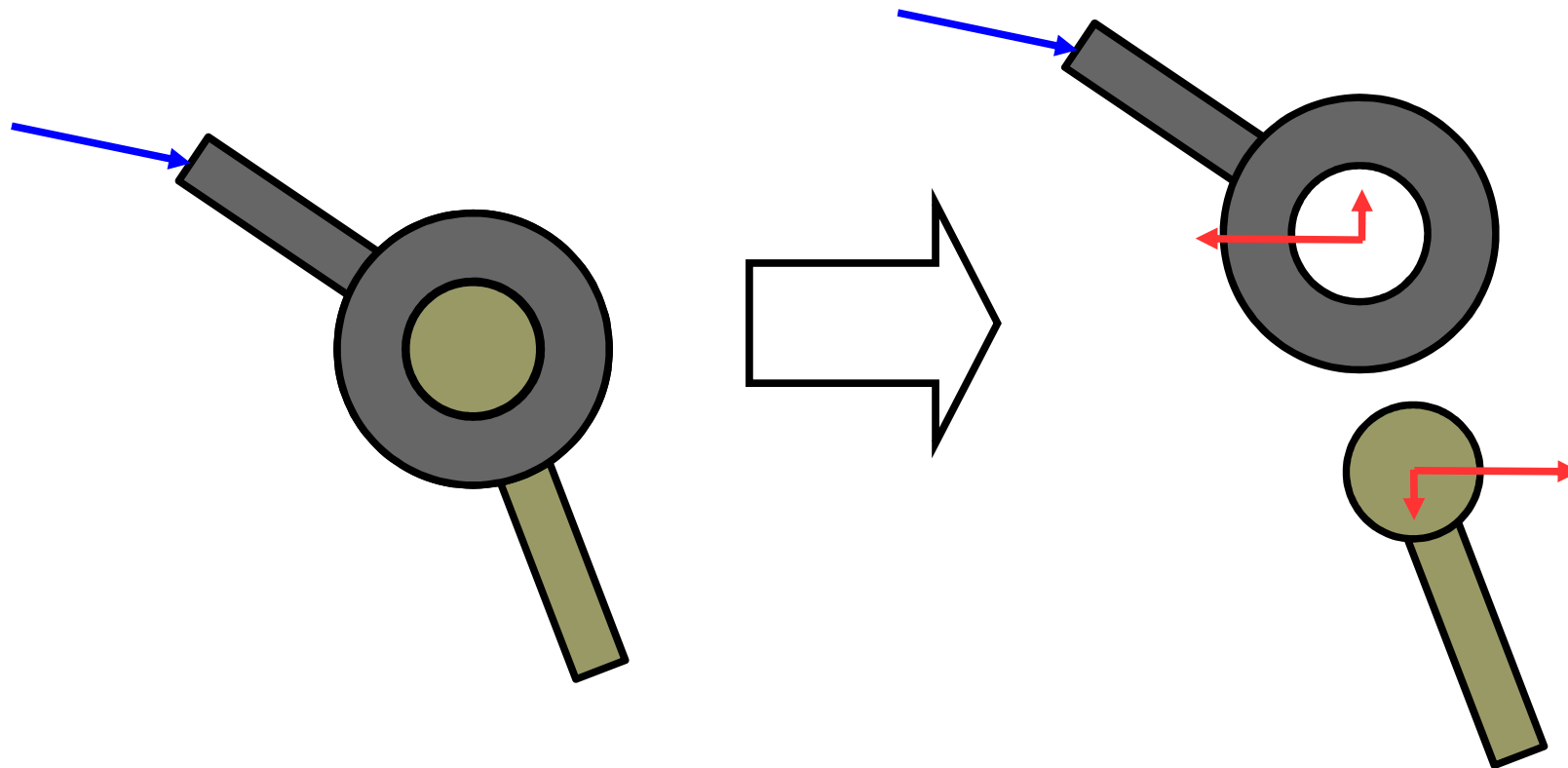

Dynamics of planar mechanisms

Driving and operating forces/torques

example – compressor

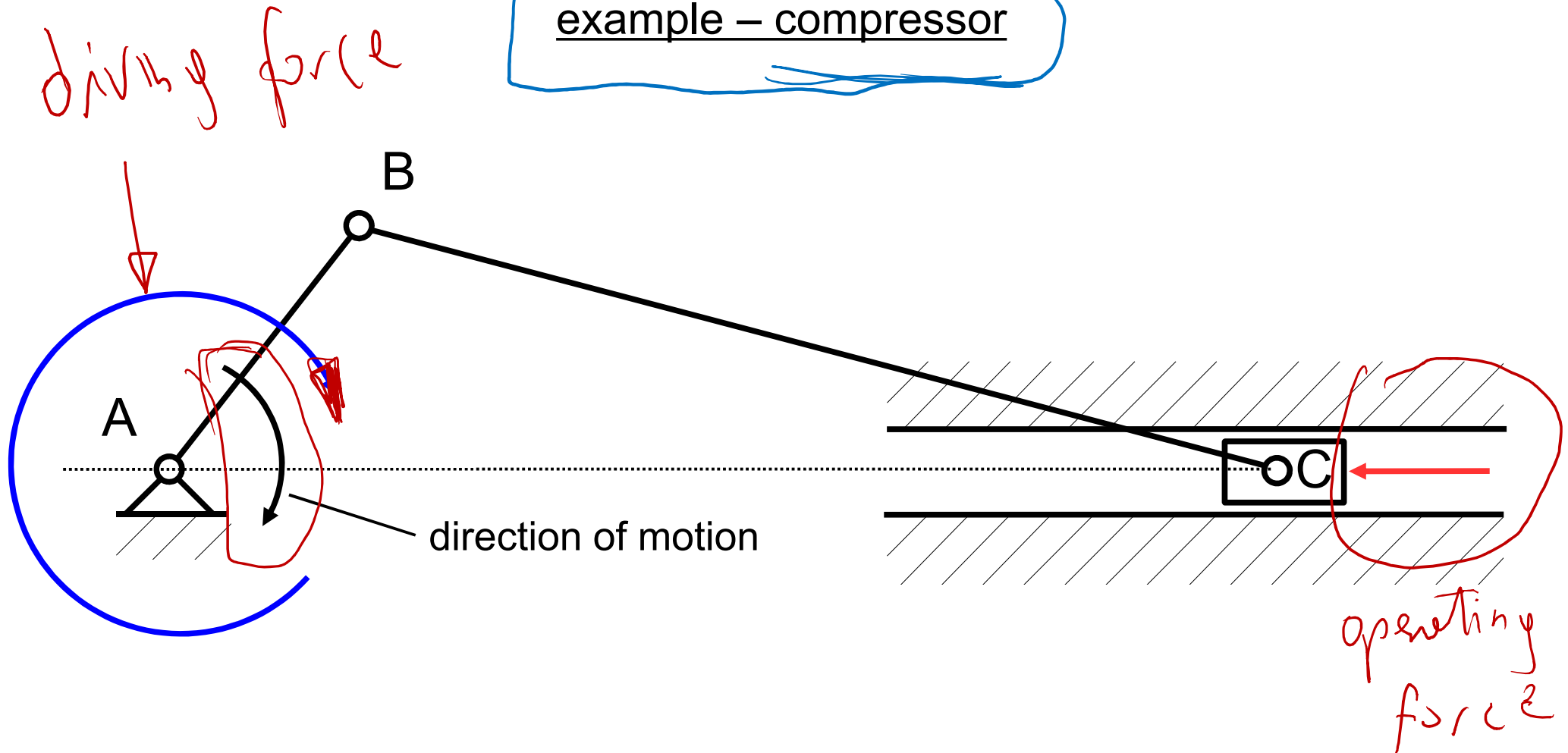

Dynamics of planar mechanisms

Driving and operating forces/torques

example – compressor

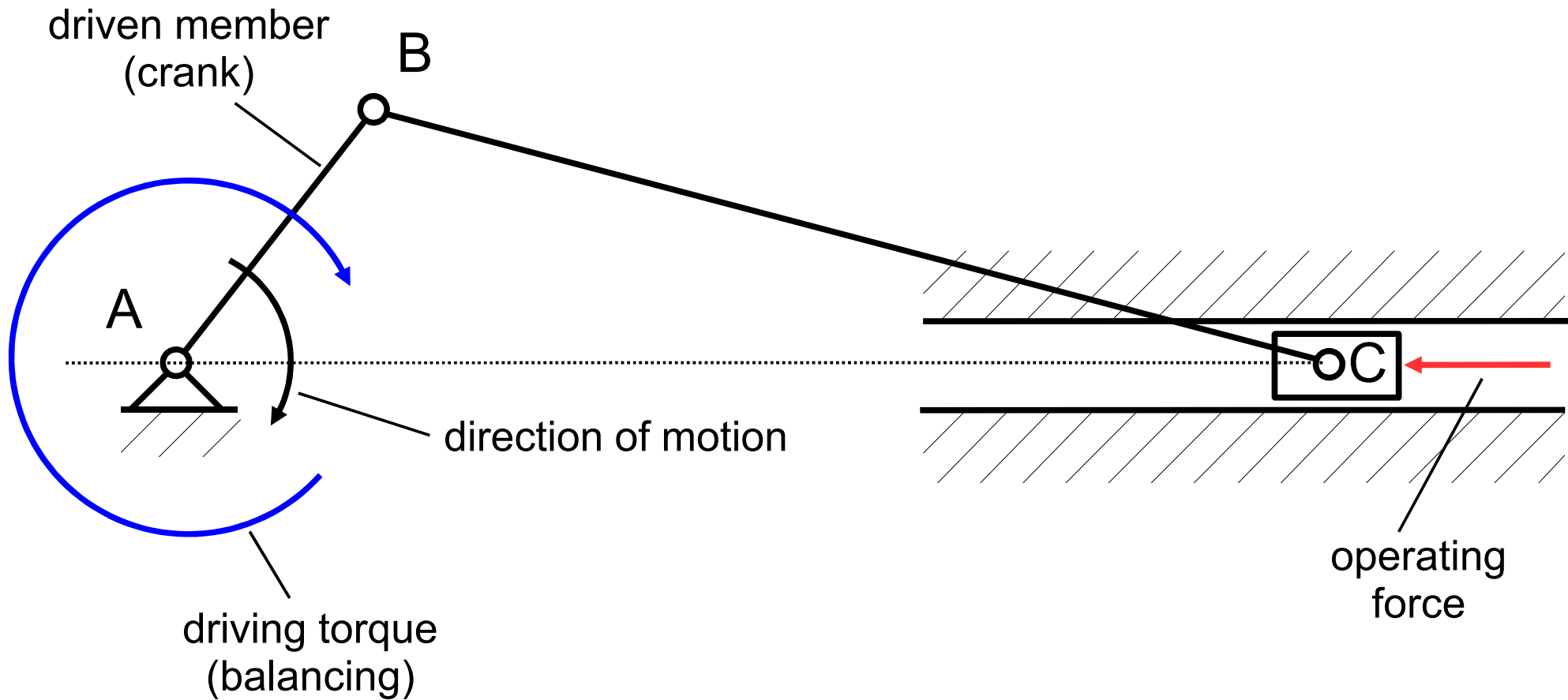

Dynamics of planar mechanisms

Driving and operating forces/torques

example – engine

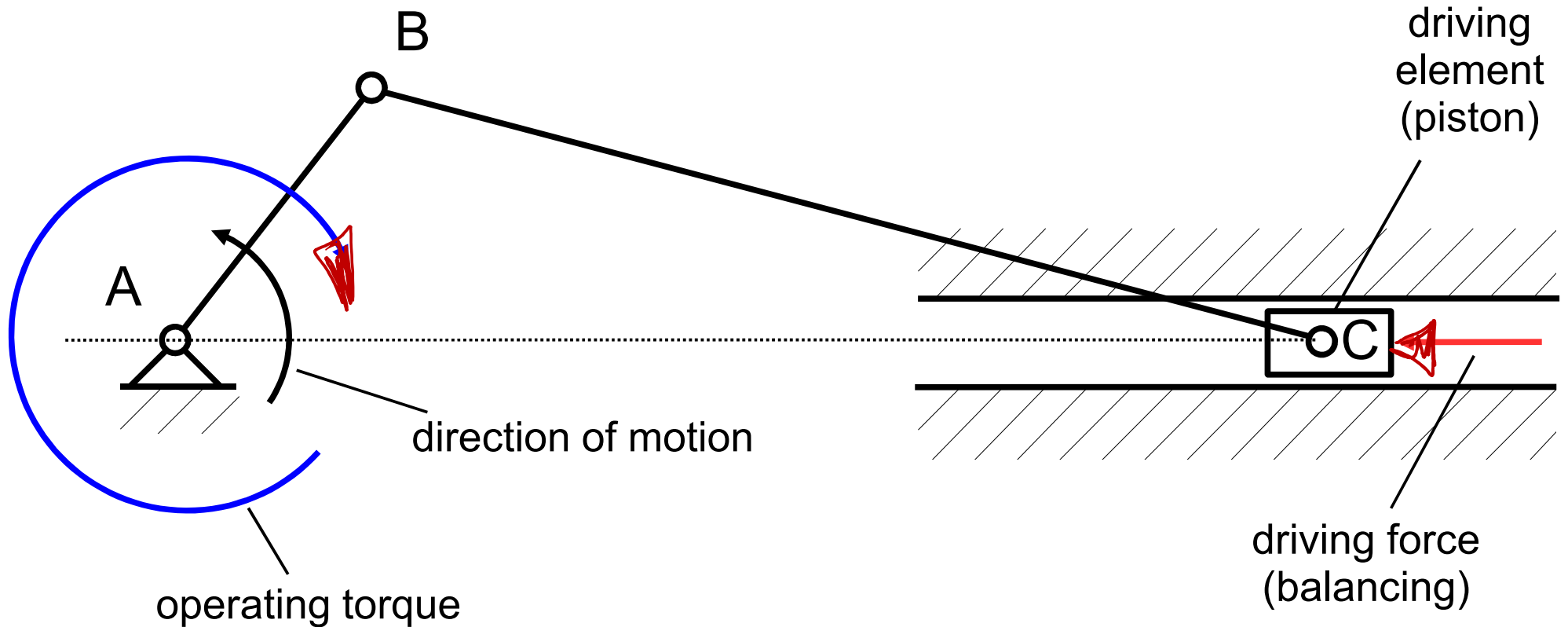

Dynamics of planar mechanisms

- ① Inverse dynamics problem – calculation of forces and torques that cause given motion of a mechanism.
- ② Direct dynamics problem – calculation of mechanism's motion caused by external forces and torques.